

Town of Carrboro

301 W. Main St., Carrboro, NC 27510



Meeting Agenda - Final

Tuesday, May 7, 2024

7:00 PM

Council Chambers - Room 110

Town Council

7:00-7:30**A. POETRY READING, RESOLUTIONS, PROCLAMATIONS, AND ACKNOWLEDGEMENTS****Memorial Day Proclamation****Bike Month Proclamation****Police Week****Period Poverty Awareness Week****7:30-7:35****B. ANNOUNCEMENT OF UPCOMING MEETINGS****7:35-7:55****C. PUBLIC COMMENT****7:55-8:05****D. CONSENT AGENDA**

1. [24-091](#) Approval of minutes from Town Council meetings held on April 4, 18, 25, and May 2, 2023.
2. [24-084](#) Town Attorney Rate Increase

PURPOSE: This item allows the Town Manager to authorize an hourly rate increase in contract with Brough Law Firm.

Attachments: [A - BLF MOU](#)
[B - Resolution Brough Rate Increase](#)
[C - Brough Rates Pocket Questions](#)

3. [24-058](#)

Resolution to Authorize a Contract

PURPOSE: To request Town Council authorize the Town Manager to award a contract to Environmental Air Systems DBA Envirotrol for replacement of the Century Center chiller and Direct Digital Control (DDC) system upgrades.

Attachments: [A - Energy and Sustainability Systems Overview](#)
[B - Century Center Chiller Replacement and DDC Controls Upgrade](#)
[C - Sud Associates, PA Bid Evaluation Form](#)
[D - Resolution](#)
[E - Race and Equity Pocket Questions](#)

4. [24-094](#)

Request to Set Legislative Public Hearing for Text Amendments

PURPOSE: To request the Town Council consider setting a public hearing on revised text amendments to the Land Use Ordinance relating to Cafes and Residential Density in Certain Zoning Districts. A resolution setting a public hearing for June 18, 2024, has been provided.

Attachments: [A - Resolution](#)
[B - Revised Draft Ordinance \(042624\)](#)
[C - Revised Draft Ordinance \(tracked\)](#)
[D - LUO Text Amendment Requests 15-146 & 15-182 signed](#)
[E - Pocket Questions](#)

5. [24-098](#)

Town Council 2023-2024 Retreat Summary

PURPOSE: This item is to provide a summary of matters discussed during the Carrboro Town Council 2023-2024 retreat that took place February 3, 2024. Important topics of discussion include council priorities for the LUO rewrite, the FY24-25 budget, and council norms.

Attachments: [A - Carrboro Town Council Retreat Summary](#)
[B - Council Retreat Pocket Questions](#)

8:05-8:20

E. OTHER MATTERS

1. [24-086](#) Report on *Carrboro Connects* Comprehensive Plan Implementation and Schedule for Land Use Ordinance Update

PURPOSE: To report on the status of comprehensive plan implementation and other priorities, including the anticipated scope and general schedule for updating the Town's land use regulations.

Attachments: [A - Carrboro Connects Projects by Chapter - Status Report](#)
[B - Priorities Identified in FY23-24 Annual Budget - Status Report](#)
[C - LUO Update \(May 2024\)](#)
[D - Pocket Questions](#)

8:20-8:30

F. MATTERS BY COUNCIL MEMBERS

8:30-9:00

G. CLOSED SESSION



Town of Carrboro

301 W. Main St., Carrboro,
NC 27510

Agenda Item Abstract

File Number: 24-091

Agenda Date: 5/7/2024
In Control: Town Council
Version: 1

File Type: Consent Agenda

Approval of minutes from Town Council meetings held on April 4, 18, 25, and May 2, 2023.



Agenda Item Abstract

File Number: 24-084

Agenda Date: 5/7/2024
In Control: Town Council
Version: 1

File Type: Consent Agenda

Town Attorney Rate Increase

PURPOSE: This item allows the Town Manager to authorize an hourly rate increase in contract with Brough Law Firm.

DEPARTMENT: Town Managers Office

CONTACT INFORMATION: Reilly Stahl, Assistant to the Town Manager, rstahl@carrboronc.gov, (919)918-7307; Marie Parker, Assistant Town Manager, mparker@carrboronc.gov, (919)918-7343; Nick Herman, Town Attorney, gnherman@broughlawfirm.com, (919)929-3905. <tel:(919)%20929-3905>

COUNCIL DIRECTION:

Race/Equity Climate Comprehensive Plan Other

INFORMATION: This legislation authorizes the town manager to approve the hourly rate increase of the town attorney. The current rate authorized is \$215 per hour, the new rate will be \$235 per hour, effective July 1, 2024, through June 30, 2026.

FISCAL IMPACT: The town has budgeted funds through the town council budget to pay for Brough Law Firm services.

RECOMMENDATION: Staff recommends council approve this item so that the increased rate may be paid after July 1, 2024.

NORTH CAROLINA

ORANGE COUNTY

MEMORANDUM OF UNDERSTANDING

1. Parties. The parties to this memorandum of understanding (“memo”) are the Town of Carrboro (the “Town”) and the law firm of The Brough Law Firm, PLLC (“Law Firm”).

2. Purpose. The purpose of this memo is to set forth the understanding between the parties concerning the nature of the relationship under which the Law Firm shall serve as the Town Attorney.

3. Scope of Service. In consideration of the compensation set forth below, Law Firm shall continue to perform for the Town all of the legal services heretofore performed by this firm during prior fiscal years. Such services shall include, without limitation, consultation with the Town Council and the town staff, attendance at Council meetings, attendance at the meetings of other boards upon request, drafting and/or review of ordinances and other documents, and representation of the Town in litigation. Not included within the scope of covered services are (i) services customarily performed by outside bond counsel, and (ii) services such as title work that can be performed more efficiently and economically by other counsel generally engaged in that work.

4. Services Performed Principally by G. Nicholas Herman. The parties acknowledge and agree that the services covered under this memorandum shall generally be performed by or under the specific direction of G. Nicholas Herman. However, the full resources of the Law Firm shall be available to the Town and other members of the firm may assist the Town when requested to do so by the Town or when Mr. Herman is unavailable or when it is otherwise cost effective for the Town to do so. In addition, the Law Firm may arrange for the Town to contract with other firms or individuals to have certain services performed for the Town by other counsel when such services can be performed more efficiently by others.

5. Compensation. The Town shall pay to Law Firm for legal services rendered during fiscal years 2024-2025 and 2025-2026 on a monthly basis according to the services performed during each month. Monthly invoices shall indicate the number of hours worked and the fees shall be calculated according to the following rates.

Nicholas Herman	\$235.00
Robert E. Hornik, Jr.	\$235.00
T.C. Morphis, Jr.	\$235.00
Albert M. Benshoff	\$235.00
Kevin R. Hornik	\$235.00
Brady N. Herman	\$235.00
Lydia E. Lavelle	\$235.00

COMPENSATION FOR SERVICES

Statements for services rendered by The Brough Law Firm, PLLC will be prepared at the end of each calendar month for the work performed during the previous month.

Your monthly statement will consist of two parts: an itemized breakdown of professional services and a list of expenses and costs advanced.

The professional services portion of your statement will be based upon the following hourly rates for the attorneys who work on your case:

G. Nicholas Herman	\$235.00
Robert E. Hornik, Jr.	\$235.00
T.C. Morphis, Jr.	\$235.00
Albert M. Benschhoff	\$235.00
Kevin R. Hornik	\$235.00
Brady N. Herman	\$235.00
Lydia E. Lavelle	\$235.00

Your statement will indicate the services performed and the date, the attorney performing the services, the hourly rate, and the total. It will also include an itemized list of additional expenses and costs advanced. These include:

- Photocopy charges for non-routine copying done for the client outside the office.
- Private express mail carriers such as Federal Express.
- Paralegal services at a rate of \$175.00 per hour.
- Mileage and travel expenses outside Chatham, Cumberland, Durham, Granville, Orange, Moore, Person, Richmond and Wake counties.
- Filing, service of process, and other fees associated with litigation.
- Fees for recording deeds and other instruments.

RESOLUTION TO AUTHORIZE THE TOWN MANAGER TO APPROVE THE HOURLY
RATE INCREASE OF THE TOWN ATTORNEY

WHEREAS, The Town of Carrboro has been in contract with Brough Law Firm to provide legal services to the town.

WHEREAS The Town of Carrboro would like to continue to receive legal services form Brough Law Firm.

WHEREAS, Brough Law Firm has increased their hourly rates from \$215 per hour to \$235 per hour.

NOW, THEREFORE BE IT RESOLVED by the Carrboro Town Council that the Council authorizes the Town Manager to execute a rate increase with Brough Law Firm at a rate of \$235 per hour.

This 7th day of May 2024.

Race and Equity Pocket Questions

Title and purpose of this initiative: Rate Increase for Brough Law Firm; This item allows the town manager to update the existing contract with Brough Law Firm in accordance with their rate increase.

Department: Town Managers Office

What are the racial and equity impacts? There are several potential impacts to race and equity due to choosing to contract a private law firm. First, there is a question of diversity and representation. A private law firm may not represent the diversity of the town, which may make it difficult for them to represent the interest of the town faithfully. Second, there is a concern of transparency and accountability. Private law firms may operate with less transparency to the public, creating a disparity in information among community members. A contracted town attorney also serves solely at the pleasure of Council and does not share close ties to staff and internal considerations in the same way that in-house attorney would.

Who is or will experience community burden? There is potential burden on marginalized communities as they may face discrimination in private law firms that they would not be subject to in the public sector. There is also the potential for burden on the taxpayers of Carrboro as a rate increase, in combination with other increases, could eventually lead to higher taxes. Law firms local to Carrboro may experience some burden because of competition from the Chapel Hill firm.

Who is or will experience community benefit? The Town of Carrboro and its partners will experience a benefit from continuing service with a trusted law provider. The town and residents of Carrboro will benefit from a neutral, outside perspective in legal matters affecting the town. The legal partners at Brough Law Firm will benefit from continued business with the town. Residents will likely feel no additional cost burden due to this change, though switching to an in-house legal service might increase annual legal costs for the town.

What are the root causes of inequity? There are no current known causes of inequity in this item. Potential areas of inequity could revolve around lack of diversity in the private law office or a cost burden that will disproportionately affect low-income residents.

What might be the unintended consequences of this action or strategy? There is a negative budget impact as the town will be responsible for paying a higher premium for legal services. There is a possibility that the demographics of the law firm do not align with the demographics of the town, making it difficult for the attorney to act in the interest of the town, lacking similar lived experiences. A potential negative result of this action is that the town could end up paying a higher rate for legal services contracted through Brough Law Firm than if they were to bring legal services in-house.



TOWN OF CARRBORO • NC
FACING RACE, EMBRACING EQUITY

How is your department planning to mitigate any burdens, inequities, and unintended consequences? The Town Managers office will budget strategically so that this rate increase is felt as little as possible by the taxpayers.



Agenda Item Abstract

File Number: 24-058

Agenda Date: 5/7/2024
In Control: Town Council
Version: 1

File Type: Consent Agenda

Resolution to Authorize a Contract

PURPOSE: To request Town Council authorize the Town Manager to award a contract to Environmental Air Systems DBA Envirotrol for replacement of the Century Center chiller and Direct Digital Control (DDC) system upgrades.

DEPARTMENT: Public Works

CONTACT INFORMATION: Keith Berger, Public Works Deputy Director, 919-918-7432, cberger@carrboronc.gov; Kevin Belanger, PE, Public Works Director, 919-918-7427, kbelanger@carrboronc.gov.

COUNCIL DIRECTION:

Race/Equity Climate Comprehensive Plan Other

Replacement of the chiller at the Century Center will address climate action and result in a direct reduction in the Town’s Green House Gas (GHG) emissions as recommended in the Town’s Climate Action Plan (Building Energy Efficiency Measures), and Comprehensive Plan (Strategy 1.2) to reduce 2010 levels of municipal greenhouse gas emissions 80% by 2030. The Comprehensive Plan prioritizes the Century Center for energy efficiency projects (Strategy 1.2A).

Race and Equity Pocket Questions can be viewed in Attachment E.

INFORMATION: Town Council previously received information on the existing condition of Town Hall, Century Center and the Public Works facility including an energy analysis that provided baseline energy use and options for energy and sustainability systems that will work towards achieving the Town’s goal of Net Zero Buildings. See attachment A - Energy and Sustainability Systems Overview.

Cooling for the Century Center is provided by a 70-ton packaged air-cooled chiller controlled by a DDC system. The Century Center chiller is aging and in need of replacement and the DDC system is obsolete and Town staff is unable to program it for effective control and energy conservation. Replacement of the existing chiller and upgrades to the DDC system will optimize the HVAC systems for maximum energy efficiency while moving toward the Town's goal of net-zero GHG emissions.

In August 2022, the Town contracted with Sud Associates, PA to provide professional chiller replacement services including:

- design services such as review of available information, selection of new chiller and ancillaries, electrical system design, development of drawings and specification’s, etc.

- bidding services such as preparation of addenda, evaluation, and tabulation of bids, etc.
- construction administration services such as equipment and shop drawing review, construction progress meetings, maintenance of a deficiency log, review and process change order requests, review pay requests, etc.

The Public Works department placed an order for the chiller on January 6, 2023. It was delivered to Public Works facility on April 18, 2023.

The Town released an Advertisement for Bids on February 26, 2024, for replacement of the Century Center chiller and DDC controls upgrade. The Scope of Work, provided by Sud Associates, PA includes:

- Demolish select existing mechanical equipment and provide new pumps, variable speed drive, etc.
- Demolish existing DDC controls and provide new BACnet IP DDC controls.
- 35 existing VAV boxes with hot water coils to remain and have their controls replaced.
- Electrical revisions required to support the mechanical changes.

A pre-bid Meeting was held on March 12, 2024. See Attachment B - Century Center Chiller Replacement and DDC Controls Upgrade.

Staff have taken steps to reach minority and women owned business enterprises (MWBE) by advertising the bid opportunity on the North Carolina Historically Underutilized Business (HUB) website. Bidders were required to make good faith efforts to include MWBE subcontractor participation and to provide documentation of outreach and participation.

A bid opening for the project was held on April 9, 2024, at 3:00 pm EST. Insufficient bids were received. The bid was readvertised on April 10, 2024. On April 17, 2024, the Town received three responses to the Advertisement for Bids. Bids were received from Comfort Systems USA (MidAtlantic) LLC, Environmental Air Systems DBA Envirotrol and Superior Mechanical Services Inc. All firms' bids were responsive and complete. The bids were reviewed by Sud Associates, PA and Town staff. Sud Associates, PA. provided a bid tabulation. See Attachment C - Sud Associates, PA Bid Evaluation Form.

Town staff recommends contracting with Environmental Air Systems DBA Envirotrol for the following reasons:

- Lowest base bid
- Highest WMB participation percentage of total base bid (6%)

FISCAL IMPACT: The Town expects to execute the contract not to exceed \$409,000. Funding for replacement of the chiller is already included in the Facilities Rehabilitation Project Budget approved by the Town Council on October 9, 2019.

RECOMMENDATION: The Town Manager recommends the Town Council adopt the resolution (Attachment D) authorizing the Town Manager to award the contract to replace the Century center chiller and upgrade the

DDC system to Environmental Air Systems DBA Envirotrol and allocate funding for the replacement of the Century Center chiller and DDC upgrade.

TOWN OF CARRBORO

Town Hall Building; Century Center Building; Public Works Complex

Net Zero Energy Study

May 6, 2021



Sud Associates, P.A

1813 Chapel Hill Road, Durham, NC 27707 Tel: (919) 493-5277
90 Southside Avenue, Suite 300, Asheville, NC 28801 Tel: (828) 255-4691

www.sudassociates.com

Introduction

Sud Associates has been engaged by Jim Spencer Architects and the Town of Carrboro (TOC) to provide energy analysis and net zero consulting services for three TOC facilities: Town Hall, the Century Center, and the Public Works complex. These services are part of a larger initiative by the TOC to develop a renovation strategy which incorporates the goals of the Town's Strategic Energy and Climate Action plan and addresses the more immediate needs of the Town and the specific buildings.

The Strategic Energy and Climate Action plan calls for Town facilities to work toward net zero energy use. Two initial steps toward that end are to define net zero explicitly and to perform energy analyses on the buildings in question. These were the focus of Sud Associates' efforts.

Energy Analysis

The purpose of the energy analysis is to inform decisions in the renovation planning and design process. Energy and water consumption models were created to help understand how energy is consumed in each building, and where the most substantial opportunities for potential savings lie. They also provide valuable information in assessing the feasibility of modifying the buildings to achieve net zero carbon emissions. Further, the models create a benchmark for each building, establishing existing consumption characteristics and allowing a metric for assessing improvements.

The energy analysis for each building was carried out using the following basic process:

- Study Facility Documents
- Analyze Utility Data
- Perform Site Visits
- Research Building Use and Schedules
- Research Building Equipment
- Create Energy Simulations
- Create Water Usage Spreadsheet Models
- Calibrate Energy Simulations and Water Models

Net Zero Consulting

Sud Associates provided consulting on the net zero process by first providing a framework and information needed to create a specific definition of the metric and boundary to be used in evaluating "net zero". Implications of the various options for defining net zero were discussed, and the Town Council settled on an official Town definition which uses greenhouse gasses (GHG) as the net zero metric and which allows off-site renewable energy to be used in offsetting a building's GHG emissions.

General strategic concepts for how to achieve net zero were also presented. Sud Associates is combining the information learned from the energy analyses with the net zero definitions chosen by the Town to provide basic recommendations for general strategic approaches to moving each building toward net zero. Approaches to renovating the HVAC systems in each building are included in these recommendations.

Contents

This document is a compilation of the various deliverables generated during this effort. These include:

- Exhibit E-1 Report: *Energy Modeling for Net Zero Energy Study*
- Exhibit E-2 Report: *Defining Net Zero Metrics and Boundaries (Draft, 11-13-2020)*
- Exhibit E-3 Presentations: *Building Energy Analysis and Defining Net Zero*
- Exhibit E-4 TOC Resolution: *A RESOLUTION FOR ADOPTING A NET ZERO DEFINITION FOR THE TOWN OF CARRBORO BUILDINGS* (including the report *Defining Net Zero Metrics and Boundaries (Final, 11-23-2020)*)
- Exhibit E-5 Presentation: *HVAC Upgrade Concepts and Recommendations*

**Town of Carrboro
Town Hall Building; Century Center Building; Public Works Complex
Energy Modeling for Net Zero Energy Study**

November 23, 2020

Background

The Town of Carrboro is considering options for renovating the Town Hall, Century Center, and the Public Works complex. The Town is seeking to develop a long-term renovation strategy while at the same time addressing immediate needs which have been identified by Town Staff. As part of the renovation effort, the Town would like to work towards the energy sustainability goals set forth in the Town's adopted Strategic Energy and Climate Action plan, which includes working toward net zero energy use.

Energy and water consumption models have been created for each of these facilities to inform decisions in the renovation planning and design process. These models are used to help understand how energy is consumed in each building, and where the most substantial opportunities for potential savings lie. They also provide valuable information in assessing the feasibility of modifying the buildings to achieve net zero carbon emissions. Further, the models create a benchmark for each building, establishing existing consumption characteristics and allowing a metric for assessing improvements.

Existing Systems

Town Hall

The Town Hall is a three-story building which houses office areas, a chamber room, a town server room, and a connected facilities maintenance shop. The exterior walls are uninsulated brick having mostly clear, double pane, operable windows. Most of the roof area is flat with recently installed rigid foam insulation above the deck.

The building is heated and cooled by 9 independent heat pump systems of varying ages. These systems are zoned to serve the basement offices, the server room, the chamber room, the north offices on the 1st floor, the south offices on the 1st floor, the 2nd floor offices, the 1st floor of the west wing, the 2nd floor of the west wing, and the shop. None of these systems supply outdoor air for ventilation.

The lighting in the building is a mix of new LED fixtures, T-8 fluorescent fixtures, and T-12 fluorescent fixtures. The plug loads are mostly typical for office areas other than the facilities shop which sees typical shop usage. Hot water is provided by a tank-type electric water heater.

Century Center

Carrboro's Century Center is a two-story historic structure which houses office areas, community activity areas, a public computer resource area, a kitchen, and a large event hall. Part of the building serves the police department, which operates 24/7. Built in 1924, the Century Center has 18" thick uninsulated masonry walls with clear, double pane, operable windows. The roof is insulated at the attic floor by 9" of blown-in fiberglass insulation.

The building is conditioned by 3 variable air volume AHUs. Two of the AHUs utilize VAV boxes with hot water reheat, while the third AHU is a single-zone VAV unit serving the large event hall. Heating is provided by a 750 MBH natural gas-fired hot water boiler, and cooling is provided by a 70 ton air-cooled packaged chiller. The AHUs and chiller are controlled by a central control system, while the boiler operates on stand-alone controls.

The majority of the lighting throughout the building is T8 tube linear tube fluorescent fixtures. Most of the plug-in equipment is typical for an office building, though the computer resource area has a higher density of computers, and the all-electric kitchen contains heavy duty commercial cooking, refrigerating, and ice making equipment. Domestic hot water is provided by two tank-type natural gas-fired hot water heaters (75 gallon and 100 gallon).

Public Works

The public works complex is collection of buildings including office areas, an auto shop, sign shop, vehicle, equipment, and materials storage areas, a fuel station, and a carwash station. The primary energy consuming building is a 6,100 square foot pre-engineered metal building with an additional 2,400 square feet of unconditioned loft storage and mechanical space. This building houses public works administration offices, a small server room, and the fleet maintenance shop.

The office areas are divided into 3 separate HVAC zones, each of which is conditioned by a natural gas furnace with split system A/C. The shop area is conditioned by a 156 MBH natural gas unit heater. The sign shop utilizes a small heat pump window unit.

Lighting is provided by a mix of LED and fluorescent fixtures. The miscellaneous electrical loads in the complex are significant and highly variable in usage. Other than standard office equipment, these include air compressors, auto lifts, car vacuums, fuel pumps, garage doors, and various shop equipment. Domestic hot water is provided by natural gas-fired instantaneous water heaters.

Historical Utility Consumption

An analysis of the historical utility data was performed as a first step in creating energy and water consumption models of the facilities. 12 months for electricity, natural gas, and water utility data were obtained for the analyses. The data used were from the 2019 calendar year to eliminate any effect from the 2020 COVID-19 pandemic shutdowns. Usage by each facility was analyzed separately.

Town Hall

The town hall does not use natural gas, as all heating, water heating, and cooking use electricity.

Electricity

The building is served by three separate electric meters. One meter serves the majority of the building, one meter serves the shop, and the server room is served from the meter serving Fire Station 1. Onsite power readings, in conjunction with Fire Station 1 utility data, allowed the annual energy consumption of the server room (servers plus HVAC) to be estimated and extracted from the Fire Station data. This estimate was added to the data from the main building meter and the shop meter to obtain a monthly set of consumption data for the entire building. This combined usage is presented below.

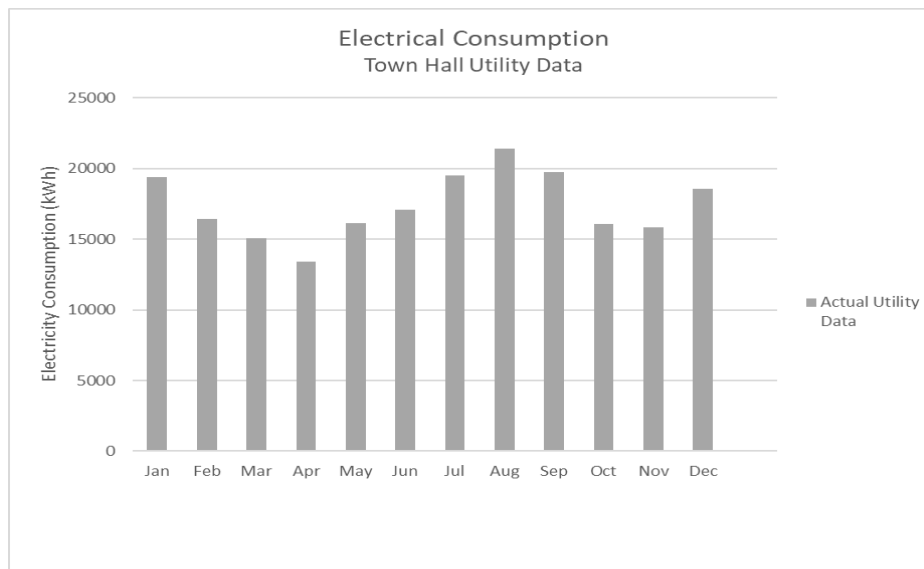

Water

A single water meter serves the building. Data from this meter are presented below.

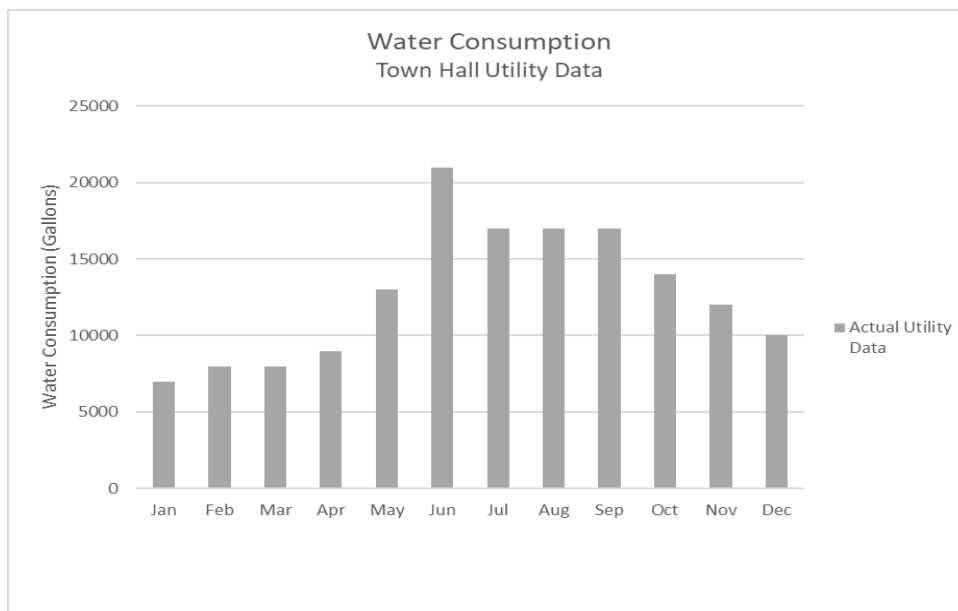

Century Center

The Century Center uses electricity, natural gas, and water.

Electricity

A single electric service entrance serves the entire building. Data from this meter are presented below.

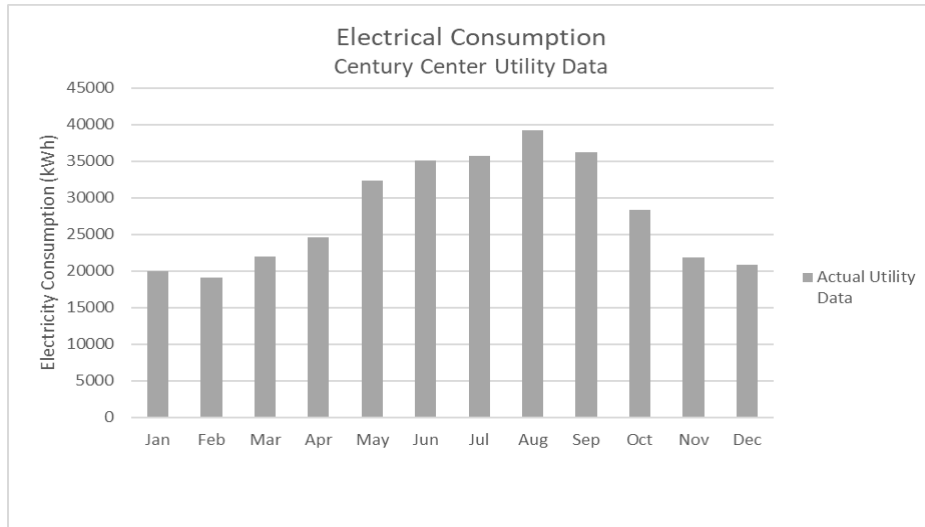

Natural Gas

A single natural gas service entrance serves the entire building. Data from this meter are presented below.

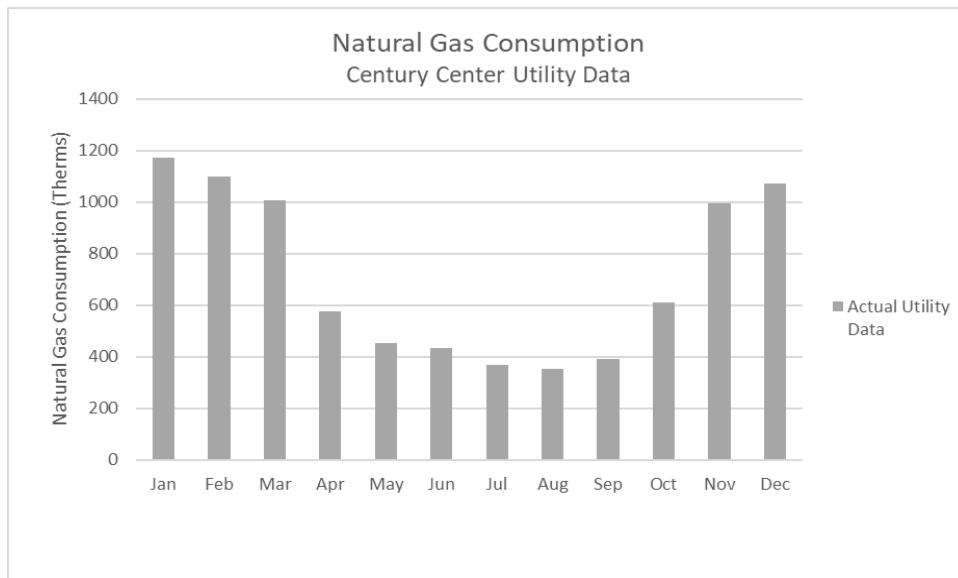

Water

A single water service entrance serves the entire building. Data from this meter are presented below.

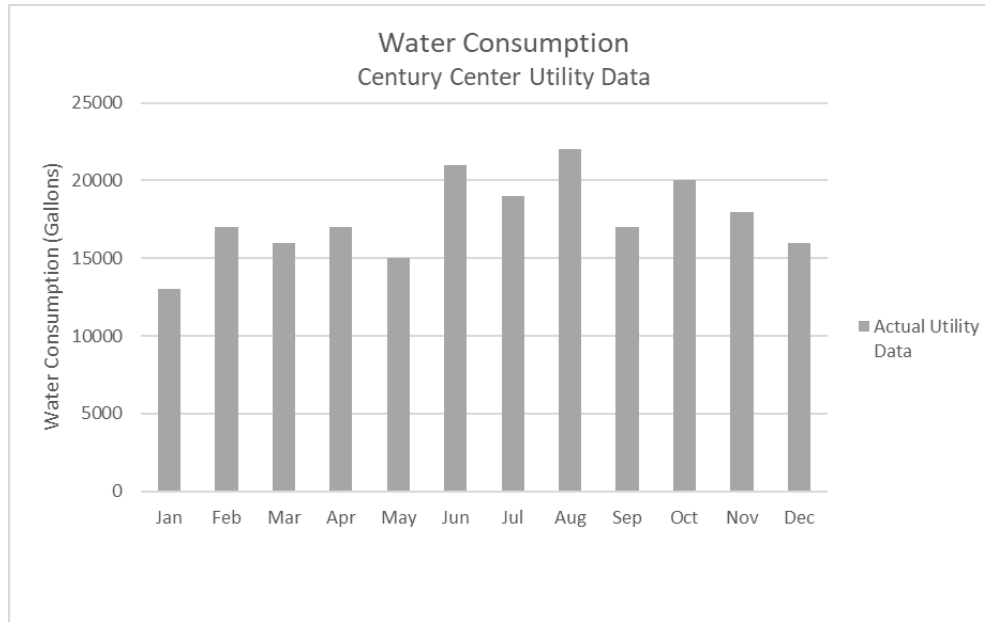

Public Works

The Public Works complex utilizes electricity, natural gas, and water.

Electricity

Public Works is served by three electric service entrances. One meter currently has no load connected to it, one meter serves the server room and its A/C unit, and one meter serves the rest of the complex. The data presented below show the combined metered usage for the complex.

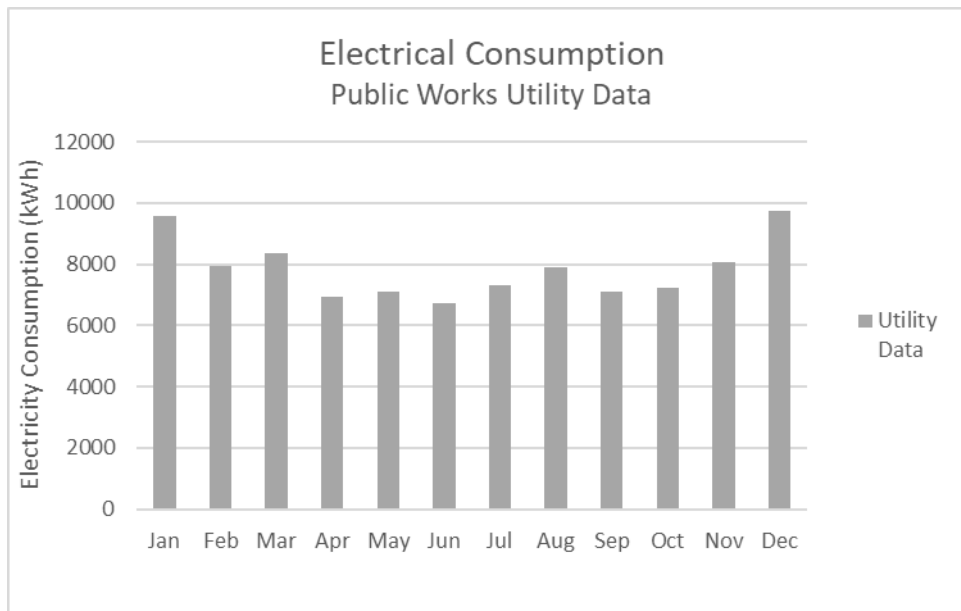

Natural Gas

Two natural gas meters serve the facility. One meter serves the generator and the instantaneous hot water heaters, and one meter serves the rest of the facility. The combined usage is shown below.

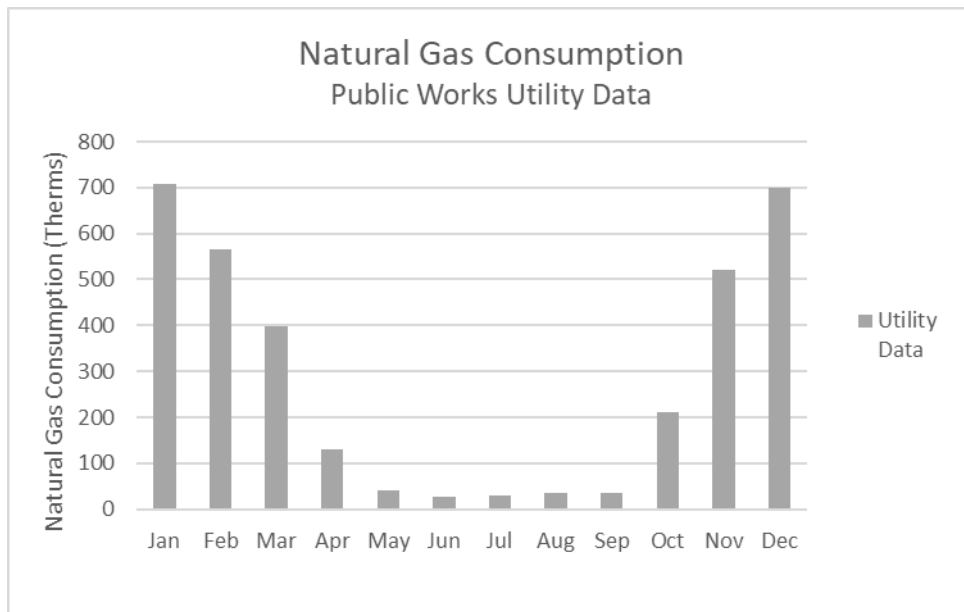

Water

A single water service serves the entire complex. Data from this meter are presented below.

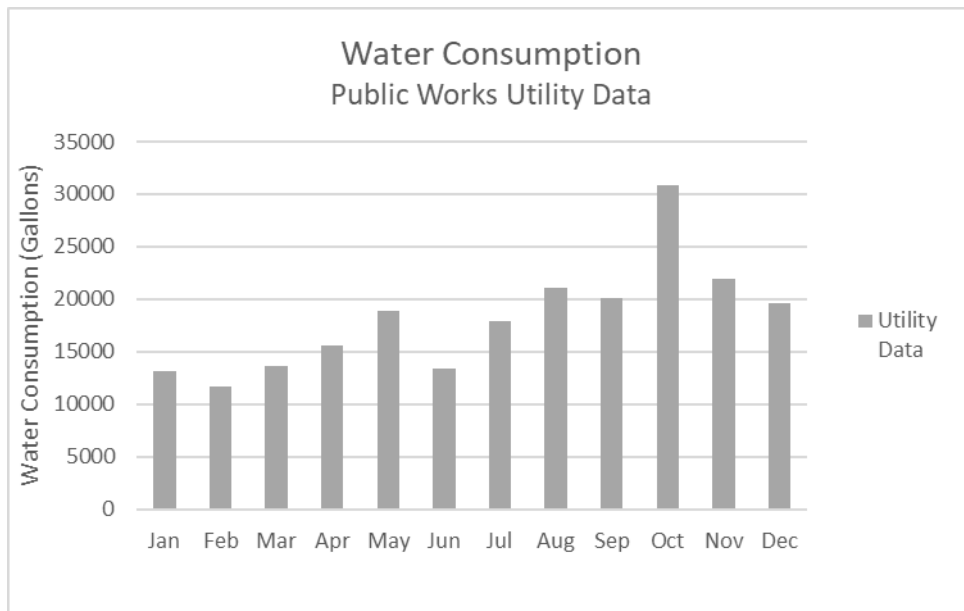

Simulation Methodology

Energy and water consumption simulations were created for each building. The energy models for the Century Center and the Town Hall were generated using the Trane TRACE software. TRACE uses a comprehensive set of environmental and building characteristics to simulate the energy consumption

for the entire building each hour of a full typical year. TRACE excels at simulating the complex interactions among various end uses, schedules, and control strategies as are found at the Century Center and Town Hall.

Due to the nature of the Public Works complex, in-house spreadsheet tools were used in lieu of TRACE to simulate annual energy usage. The usage of this facility is highly dependent on inconsistent variables such as the amount of time garage doors are open, frequency of shop equipment use, frequency and duration of car washes, etc. This type of facility is best modeled using versatile, transparent, independent calculations in conjunction with known historical utility data. Through this approach a more reliable and understandable breakdown of how the facility uses energy can be obtained.

Hourly energy simulations require detailed weather data for the specific location of the buildings. TMY3 (Typical Meteorological Year) weather files for the Durham area were utilized for the Carrboro models. Building inputs include the constructions of the walls, windows, roofs, and floor systems, HVAC equipment and control strategies, room-by-room lighting systems, plug-in equipment, and occupancy, domestic hot water systems, and schedules of usage for occupants and each energy end use. The values utilized in the Carrboro models were obtained via building drawings, site visits, measurements, and conversations with Carrboro staff.

Water models are generally much less complex than energy simulations. These are usually analyzed on an annual basis, as hourly calculations would provide little additional value to understanding the facility. In-house spreadsheet tools were used for these models. The primary inputs for these models are occupancy types, general occupancy schedules, and the various water-using fixture data.

Energy and Water Model Results and Calibration

Each energy and water model was calibrated to match the historical utility consumption to within an acceptable error tolerance based on industry standard practice. The Carrboro energy models were calibrated such that the modeled electricity and natural gas consumption is within 10% of the actual consumption for each month of the year, and within 5% of the total annual consumption. The water models were calibrated to within 5% of the annual consumption.

Town Hall

The energy consumption results for the Town Hall are presented below, along with its energy use intensity.

Town Hall Energy Consumption Profile		
End Use	Energy Consumption (kBTU/yr)	Percent of Total
Heating	83,044	11.7%
Cooling	169,247	23.9%
Fans/Pumps	99,651	14.1%
Lighting	119,697	16.9%
DHW	9,687	1.4%
Plug Loads / Other	228,125	32.2%
Total	709,451	100%
Conditioned Area (sf)	12,235	
Energy Use Intensity (kBTU/sf/yr)	57.99	

The calibrated results for the Town Hall building are presented below. A breakdown of the energy model results is provided in Appendix I.

Electricity (Town Hall)

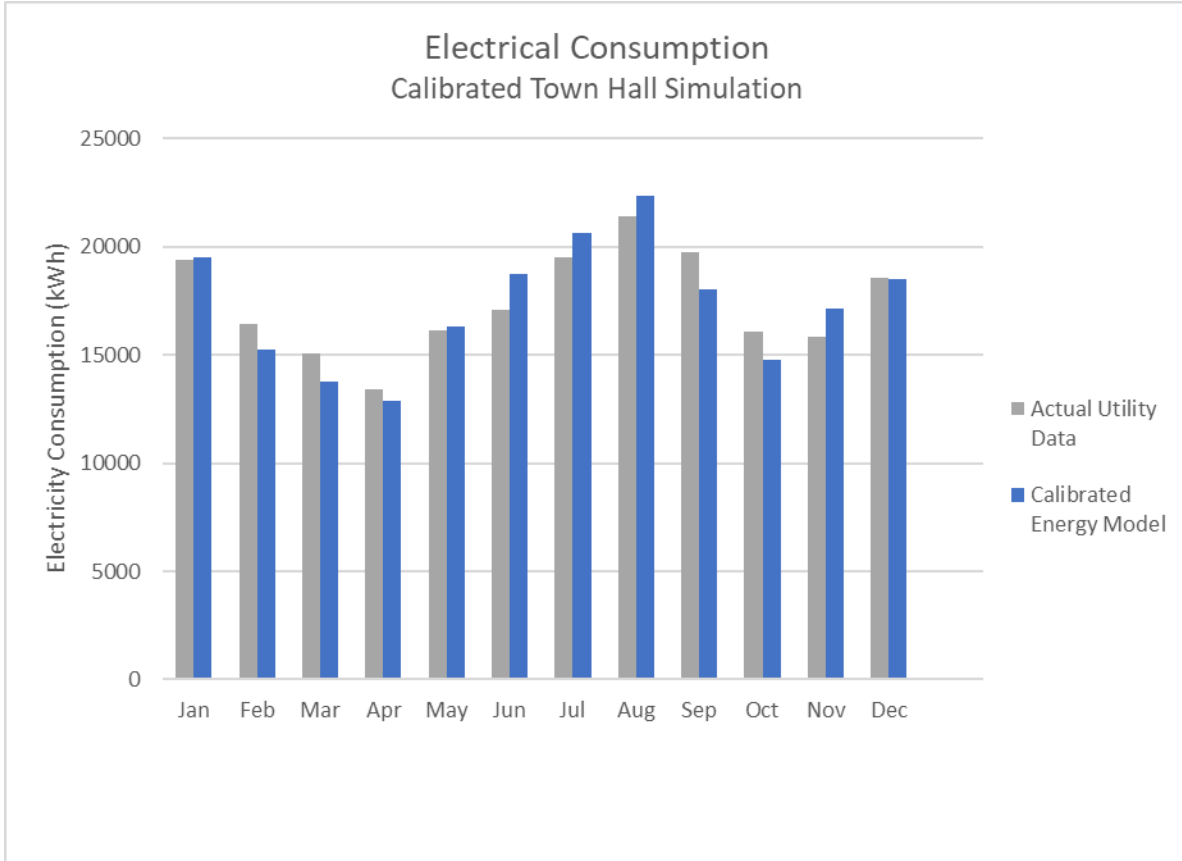

Town Hall Electricity Consumption (kWh)			
Month	Actual Utility Data	Calibrated Model	% Error
Jan	19376	19511	1%
Feb	16401	15249	-7%
Mar	15073	13769	-9%
Apr	13404	12849	-4%
May	16112	16328	1%
Jun	17091	18748	10%
Jul	19536	20641	6%
Aug	21386	22342	4%
Sep	19764	18056	-9%
Oct	16086	14755	-8%
Nov	15835	17120	8%
Dec	18583	18499	0%
Total	208646	207867	0%

Water (Town Hall)

Town Hall Water Consumption (gal)			
Period	Actual Utility Data	Calibrated Model	% Error
Annual	155734	155731	0%

Century Center

The energy consumption results for the Century Center are presented below, along with its energy use intensity.

Century Center Energy Consumption Profile		
End Use	Energy Consumption (kBTU/yr)	Percent of Total
Heating	848,026	42.7%
Cooling	224,216	11.3%
Fans/Pumps	548,968	27.6%
Lighting	203,910	10.3%
DHW	13,420	0.7%
Plug Loads / Other	147,747	7.4%
Total	1,986,287	100%
Conditioned Area (sf)	19,912	
Energy Use Intensity (kBTU/sf/yr)	99.75	

The calibrated results for the Century Center are presented below. A breakdown of the energy model results is provided in Appendix II

Electricity (Century Center)

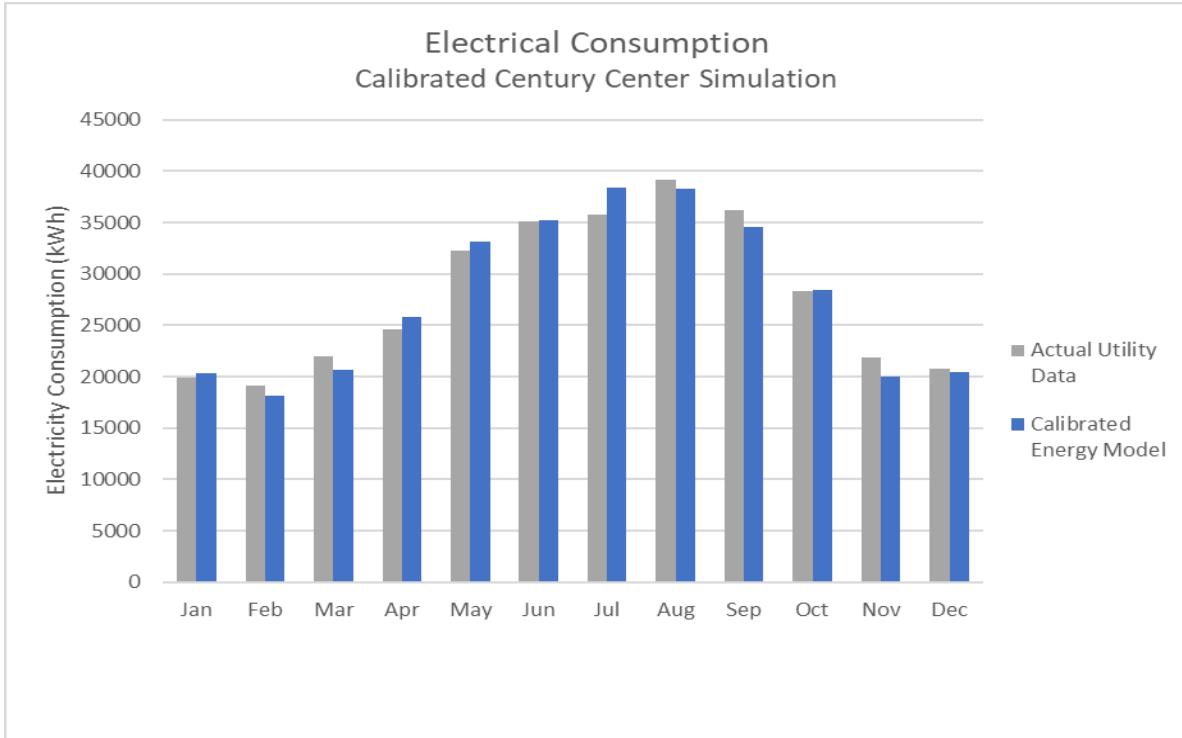

Century Center Electricity Consumption (kWh)			
Month	Actual Utility Data	Calibrated Model	% Error
Jan	19932	20377	2%
Feb	19082	18203	-5%
Mar	21936	20665	-6%
Apr	24586	25760	5%
May	32315	33172	3%
Jun	35082	35268	1%
Jul	35727	38364	7%
Aug	39209	38241	-2%
Sep	36198	34531	-5%
Oct	28286	28423	0%
Nov	21833	19996	-8%
Dec	20796	20465	-2%
Total	334982	333463	0%

Natural Gas (Century Center)

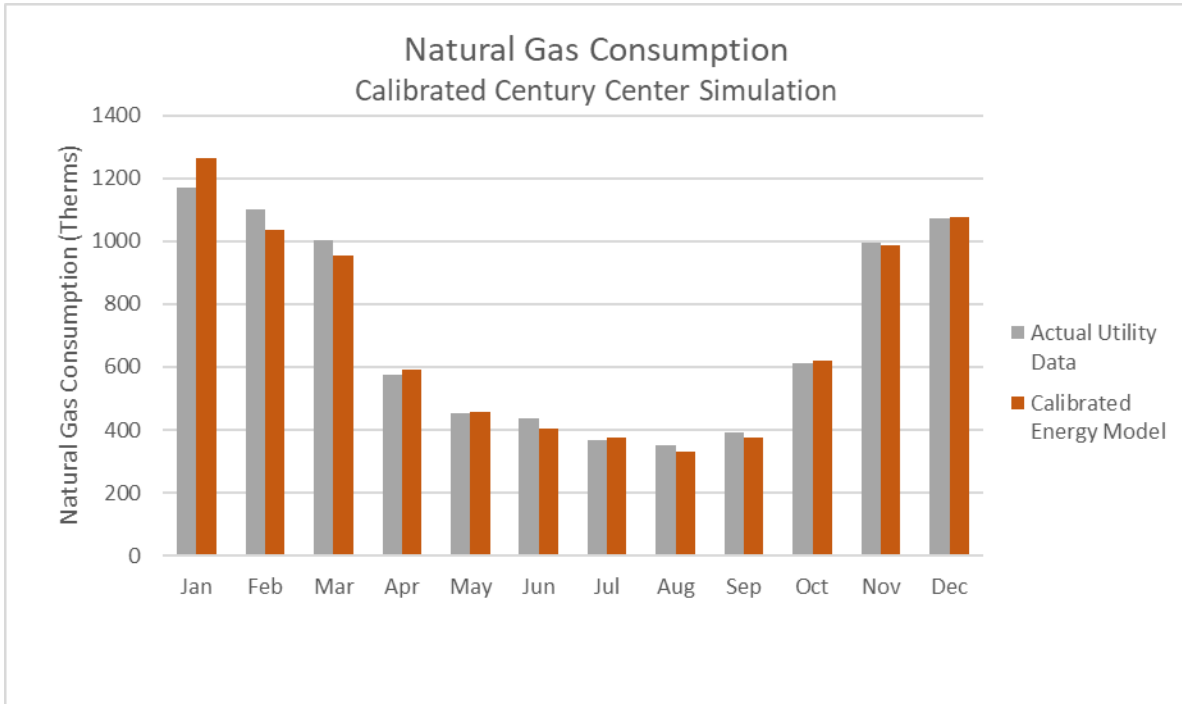

Century Center Natural Gas Consumption (therms)			
Month	Actual Utility Data	Calibrated Model	% Error
Jan	1170	1263	8%
Feb	1100	1035	-6%
Mar	1005	955	-5%
Apr	574	592	3%
May	451	458	2%
Jun	435	406	-7%
Jul	366	377	3%
Aug	351	331	-6%
Sep	390	377	-3%
Oct	611	622	2%
Nov	995	987	-1%
Dec	1073	1078	0%
Total	8522	8482	0%

Water (Century Center)

Century Center Water Consumption (gal)			
Period	Actual Utility Data	Calibrated Model	% Error
Annual	219416	219264	0%

Public Works

The energy consumption results for the Town Hall are presented below, along with its energy use intensity.

Public Works Energy Consumption Profile		
End Use	Energy Consumption (kBTU/yr)	Percent of Total
Heating	306,672	44.3%
Cooling	62,858	9.1%
Fans	36,683	5.3%
Lighting	54,922	7.9%
DHW/Carwash/Generator	30,900	4.5%
Office Equipment	15,861	2.3%
Server	15,040	2.2%
Air Compressor	24,088	3.5%
Shop/Site Equipment	11,495	1.7%
Currently Unaccounted	133,601	19.3%
Total	692,120	100%
Conditioned Area (sf)	6,300	
Energy Use Intensity (kBTU/sf/yr)	109.9	

Note that the model is unable to account for a large percentage of the electrical consumption in the facility. This is shown in the table above as “Currently Unaccounted”, and in the electricity chart and table below as the percent error between the model and the utility data. The tables below show the energy model results as compared to the utility data. See Appendix III for a breakdown of modeled end uses.

Electricity (Public Works Complex)

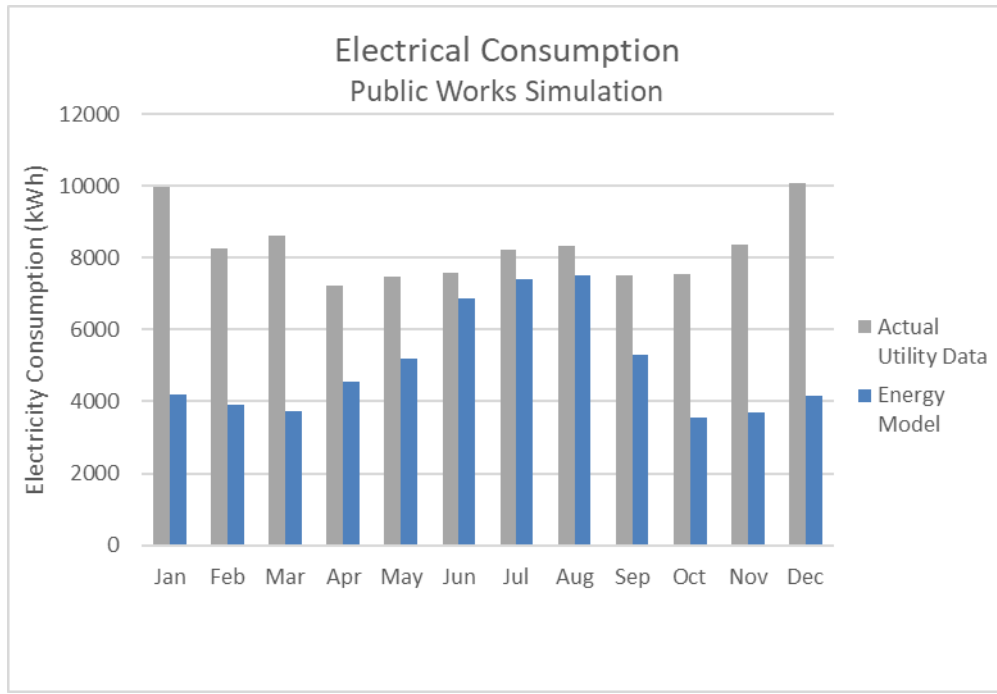

Public Works Electricity Consumption (kWh)			
Month	Actual Utility Data	Calibrated Model	% Error
Jan	9965	4193	58%
Feb	8277	3919	53%
Mar	8606	3726	57%
Apr	7229	4549	37%
May	7472	5190	31%
Jun	7600	6868	10%
Jul	8231	7419	10%
Aug	8330	7522	10%
Sep	7511	5288	30%
Oct	7553	3535	53%
Nov	8355	3710	56%
Dec	10079	4143	59%
Total	99208	60063	39%

Natural Gas (Public Works Complex)

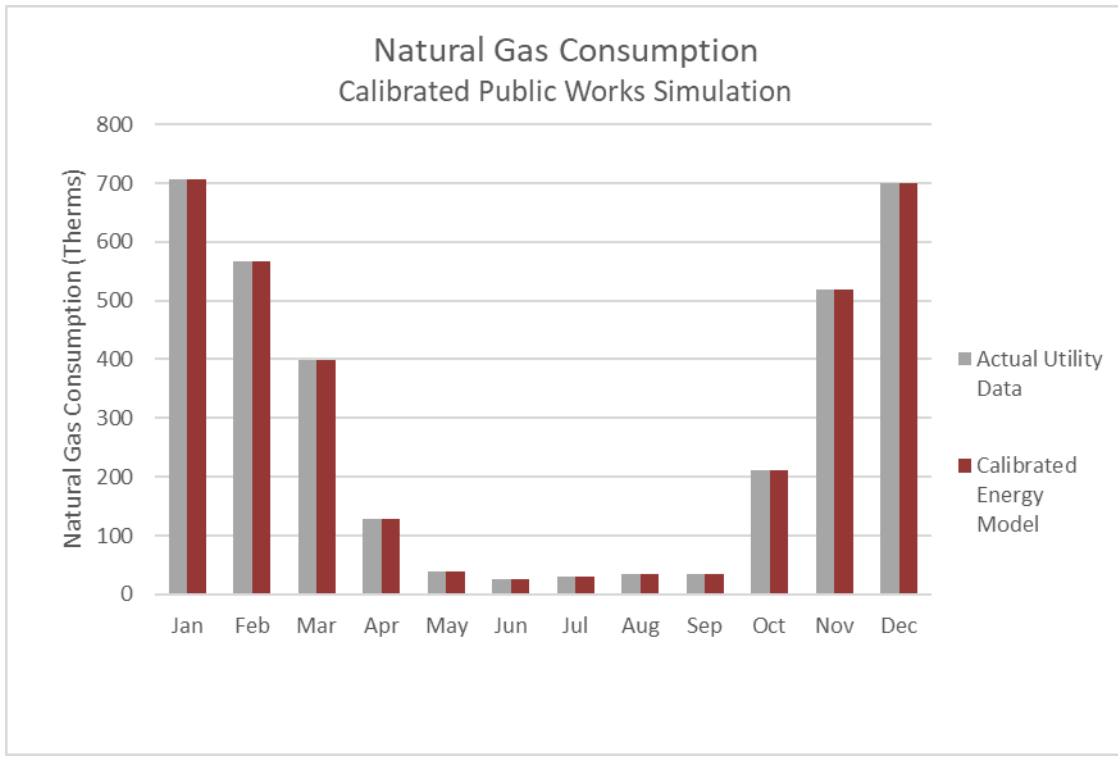

Public Works Natural Gas Consumption (therms)			
Month	Actual Utility Data	Calibrated Model	% Error
Jan	707	707	0%
Feb	566	566	0%
Mar	399	399	0%
Apr	129	129	0%
May	40	40	0%
Jun	26	26	0%
Jul	31	31	0%
Aug	35	35	0%
Sep	35	35	0%
Oct	210	210	0%
Nov	520	520	0%
Dec	699	699	0%
Total	3397	3397	0%

Water (Public Works Complex)

Public Works Water Consumption (Gallons)			
Period	Actual Utility Data	Calibrated Model	% Error
Annual	217948	216000	1%

Conclusions

The creation of energy models allows a better understanding of how resources are used within a facility, and can offer insight as to what opportunities there may be to save energy and water. These results will be used to guide design decisions moving forward in the process of upgrading these three facilities. The energy and water simulations for the Century Center and the Town Hall reconcile cleanly with the utility data. The natural gas and water models for the Public Works facility also match the utility data. Currently, however, there are unknown factors resulting in discrepancies between simulations and utility data for the electricity consumption at Public Works. This should be further investigated, as the large discrepancy could point to energy saving opportunities.

Appendix I

TRACE Energy Consumption Summary (Town Hall)

ENERGY CONSUMPTION SUMMARY

By Sud Associates, P.A.

	Elect Cons. (kWh)	% of Total Building Energy	Total Building Energy (kBtu/yr)	Total Source Energy* (kBtu/yr)
Alternative 1				
Primary heating				
Primary heating	24,332	11.7 %	83,044	249,156
Other Htg Accessories		0.0 %	0	0
Heating Subtotal	24,332	11.7 %	83,044	249,156
Primary cooling				
Cooling Compressor	39,897	19.2 %	136,167	408,541
Tower/Cond Fans	4,758	2.3 %	16,239	48,721
Condenser Pump		0.0 %	0	0
Other Clg Accessories	4,935	2.4 %	16,842	50,530
Cooling Subtotal....	49,589	23.9 %	169,247	507,792
Auxiliary				
Supply Fans	29,198	14.1 %	99,651	298,984
Pumps		0.0 %	0	0
Stand-alone Base Utilities	2,838	1.4 %	9,687	29,064
Aux Subtotal....	32,036	15.4 %	109,338	328,048
Lighting				
Lighting	35,071	16.9 %	119,697	359,128
Receptacle				
Receptacles	66,840	32.2 %	228,125	684,443
Cogeneration				
Cogeneration		0.0 %	0	0
Totals				
Totals**	207,867	100.0 %	709,451	2,128,567

* Note: Resource Utilization factors are included in the Total Source Energy value .

** Note: This report can display a maximum of 7 utilities. If additional utilities are used, they will be included in the total.

Project Name:
Dataset Name: CARBROTWNHLL2.TRC

TRACE® 700 v6.3.5 calculated at 08:28 PM on 09/28/2020
Alternative - 1 Energy Consumption Summary report page 1

Appendix II

TRACE Energy Consumption Summary (Century Center)

ENERGY CONSUMPTION SUMMARY

By Sud Associates, P.A.

	Elect Cons. (kWh)	Gas Cons. (kBtu)	Water Cons. (1000 gals)	% of Total Building Energy	Total Building Energy (kBtu/yr)	Total Source Energy* (kBtu/yr)
Alternative 1						
Primary heating						
Primary heating		833,181		42.0 %	833,181	877,032
Other Htg Accessories	4,350		27	0.8 %	14,845	44,539
Heating Subtotal	4,350	833,181	27	42.7 %	848,026	921,571
Primary cooling						
Cooling Compressor	58,800			10.1 %	200,685	602,115
Tower/Cond Fans	6,315			1.1 %	21,553	64,667
Condenser Pump				0.0 %	0	0
Other Clg Accessories	580			0.1 %	1,978	5,934
Cooling Subtotal....	65,695			11.3 %	224,216	672,716
Auxiliary						
Supply Fans	72,367			12.4 %	246,990	741,045
Pumps	73,385			12.6 %	250,463	751,463
Stand-alone Base Utilities	14,632	14,997		3.3 %	64,935	165,615
Aux Subtotal....	160,384	14,997		28.3 %	562,388	1,658,123
Lighting						
Lighting	59,745			10.3 %	203,910	611,791
Receptacle						
Receptacles	43,290			7.4 %	147,747	443,287
Cogeneration						
Cogeneration				0.0 %	0	0
Totals						
Totals**	333,463	848,178	27	100.0 %	1,986,287	4,307,489

* Note: Resource Utilization factors are included in the Total Source Energy value .

** Note: This report can display a maximum of 7 utilities. If additional utilities are used, they will be included in the total.

Project Name:
Dataset Name: CARBROCENTCTR24.TRC

TRACE® 700 v6.3.5 calculated at 02:17 PM on 10/14/2020
Alternative - 1 Energy Consumption Summary report page 1

Appendix III

Energy Consumption Summary Charts (Public Works)

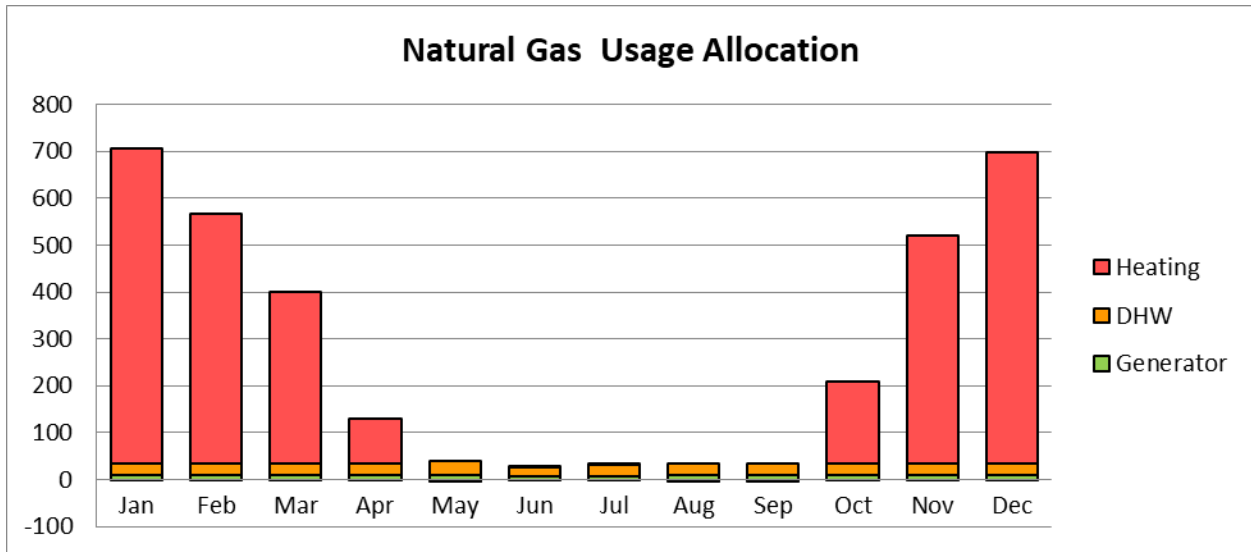
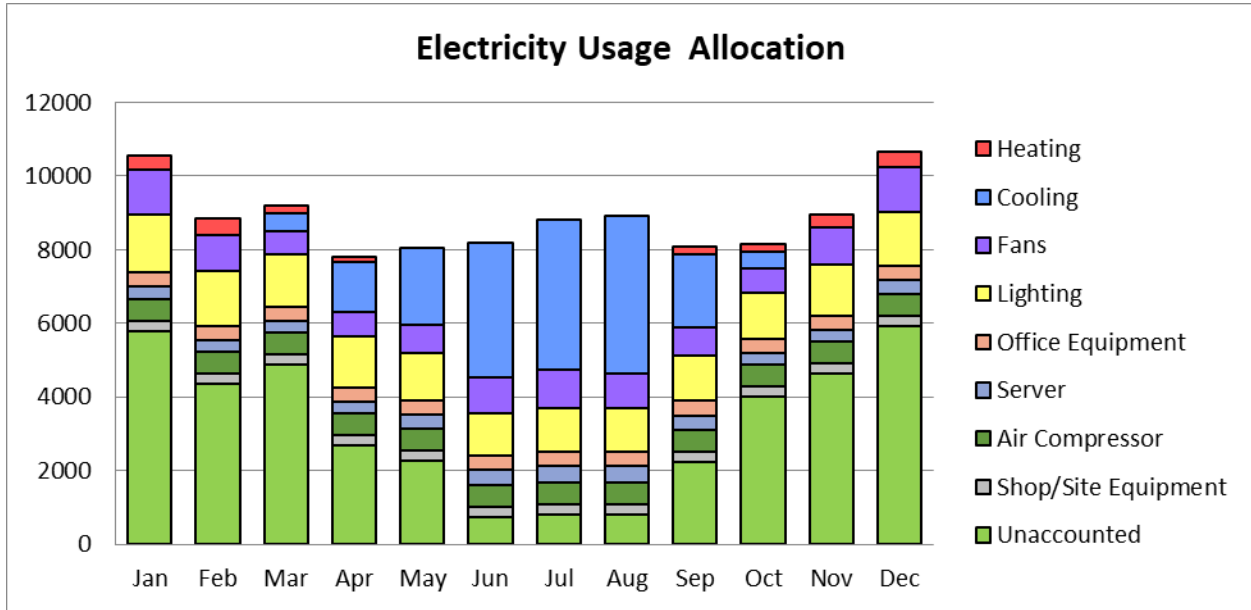

Town of Carrboro
Town Hall Building; Century Center Building; Public Works Complex
Defining Net Zero Metrics and Boundaries

November 13, 2020

DRAFT REPORT

Background

The Town of Carrboro is considering options for renovating the Town Hall, Century Center, and the Public Works complex. The Town is seeking to develop a long-term renovation strategy while at the same time addressing immediate needs which have been identified by Town Staff. As part of the renovation effort, the Town would like to work towards the energy sustainability goals set forth in the Town's adopted Strategic Energy and Climate Action plan, which includes working toward net zero energy use.

A first step in the process of achieving a net zero energy building is to define the term "net zero" and to establish the criteria for a net zero energy building. This is more than an exercise in semantics, as the definition and criteria chosen can have significant effects on design decisions and project costs.

Defining "Net Zero"

The basic idea of a net zero energy building is that, over the course of a year, it has completely offset its energy usage by renewable energy production. Beyond this general concept, there is no single, universally accepted definition for a net zero energy building. The exact definition used for any given project is a choice made by the building owners and project team based on motivations, priorities, budget, building and site characteristics, and other constraints. The US DOE and the National Renewable Energy Laboratory (NREL) have developed a clear framework and guidance to aid owners and designers in choosing the defining criteria for their specific project.

In short, there are two decisions to be made: what metric will be used to evaluate the building's performance (i.e. net zero what?), and what is the boundary within which renewable energy may be generated? Each of these questions is addressed below.

Defining the Metric

NREL has presented 4 options for defining the metric by which a net zero building can be evaluated: Site energy consumption, source energy consumption, greenhouse gas (GHG) emissions, and energy cost.

Option 1: Net Zero Site Energy: A net zero site energy building will offset the energy it uses on site with renewable energy. The energy consumed is seen directly on the building's utility bills. Some owners see net zero site energy as an attractive metric primarily because it is easy to understand and its calculation does not depend on complex factors outside the boundary of the building. This metric steers designers away from natural gas as a heat or domestic hot water fuel in favor of heat pumps or even electric resistance heating. Solar hot water is often a more attractive renewable energy source than photovoltaics under this metric.

Option 2: Net Zero Source Energy: The source energy metric considers the source of the energy used in the building. For instance, the source energy metric would account not for the electricity used in the building, but for the coal used at the power plant to produce the electricity used in the building. This metric is favored by owners whose primary motivation is to conserve the Earth’s fossil-based energy sources and to reduce the environmental damage associated with the extraction of these fuels. Using this approach largely levels the field when comparing natural gas heating versus electric heat pumps.

Option 3: Net Zero GHG Emissions: This metric is based on the GHG emissions associated with the energy used in the building rather than the energy itself. For instance, the GHG emissions metric would account not for the electricity used in the building, but rather for the airborne pollution generated by the power plant as it produces the electricity used in the building. A net zero GHG building might also be called a “carbon neutral” building. Net zero GHG emissions is chosen by owners whose primary motivation is to mitigate climate change. This metric favors the use of natural gas over electricity use, and places high value on producing renewable electricity (e.g. photovoltaic panels).

Option 4: Net Zero Energy Cost: A net zero energy cost building will offset the building’s energy cost over the course of a year with renewable energy sold to the grid or other users. This metric is perhaps the simplest to understand, but it may not fit with the Town’s Climate Action Plan. The most attractive systems and fuel types under this metric are variable, depending on the comparative market rates of the different fuels.

Defining the Boundary

Any net zero building will require renewable energy either to power the building directly or (more likely) to offset the building’s consumption of non-renewable energy. Where this renewable energy can be generated in order to count towards this offset is determined by the building owners and project team. NREL has presented 4 options, in order of decreasing constraint: building footprint generation, building site generation, imported renewables, and purchased generation.

Option A: Building Footprint Generation: This option applies the constraint that all renewable energy must be generated within the footprint of the building itself. A common example of this would be PV panels installed on the building’s roof.

Option B: Building Site Generation: Renewable energy may be generated anywhere within the property lines of the net zero building. Under this option, for example, a building may have PV panels on its roof as well as on the ground or on an on-site parking canopy.

Option C: Imported Renewables: Under this option, renewable energy may be imported from off-site and used on-site. A typical example would be biomass or biofuels used for heating. This option simply expands options for renewable generation, it does not exclude the possibility that some energy may still be generated on the building or the building site.

Option D: Purchased Generation: This option allows renewable energy to be generated by others and purchased by the building. This is often done in the form of Renewable Energy Credits (RECs). In this case the renewable energy itself is not necessarily used in the building, but the offsets created by the renewable energy are purchased and claimed by the building owners. Under this option, each of the previous three options may be included in the total mix of generation possibilities.

BUILDING ENERGY ANALYSIS TOWN OF CARRBORO

Town Hall
Century Center
Public Works

Presented to Town Council, 12/1/2020



PROCESS

- Study Facility Documents
- Analyze Utility Data
- Perform Site Visits
- Research Building Use and Schedules
- Research Building Equipment
- Create Energy Simulations
- Create Water Usage Spreadsheet Models
- Calibrate Energy Simulations and Water Models



TOWN HALL



SIMULATED ENERGY SUMMARY

Town Hall Energy Consumption Profile		
End Use	Energy Consumption (kBTU/yr)	Percent of Total
Heating	83,044	11.7%
Cooling	169,247	23.9%
Fans/Pumps	99,651	14.1%
Lighting	119,697	16.9%
DHW	9,687	1.4%
Plug Loads / Other	228,125	32.2%
Total	709,451	100%
Conditioned Area (sf)	12,235	
Energy Use Intensity (kBTU/sf/yr)	57.99	



ELECTRICITY

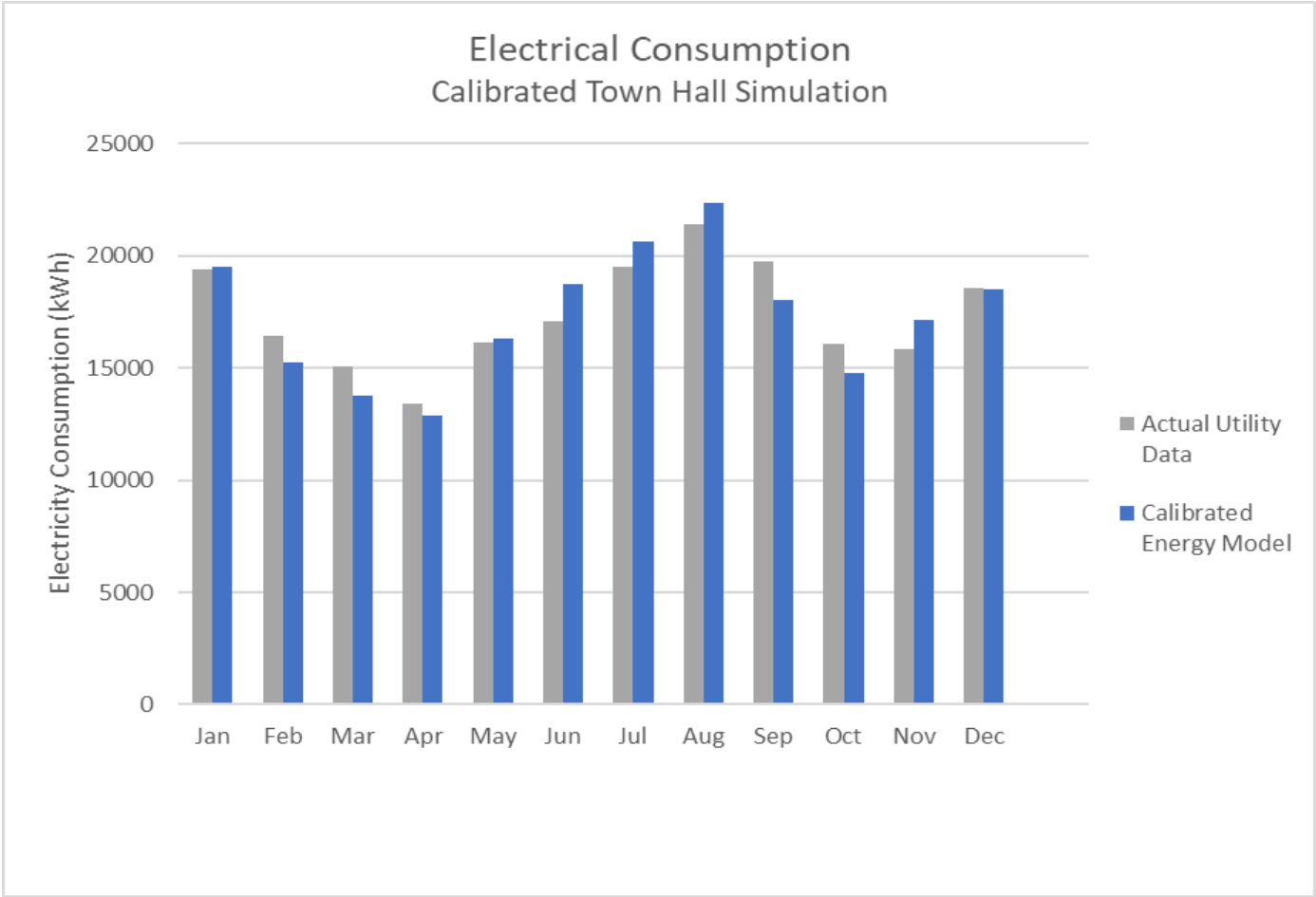

WATER

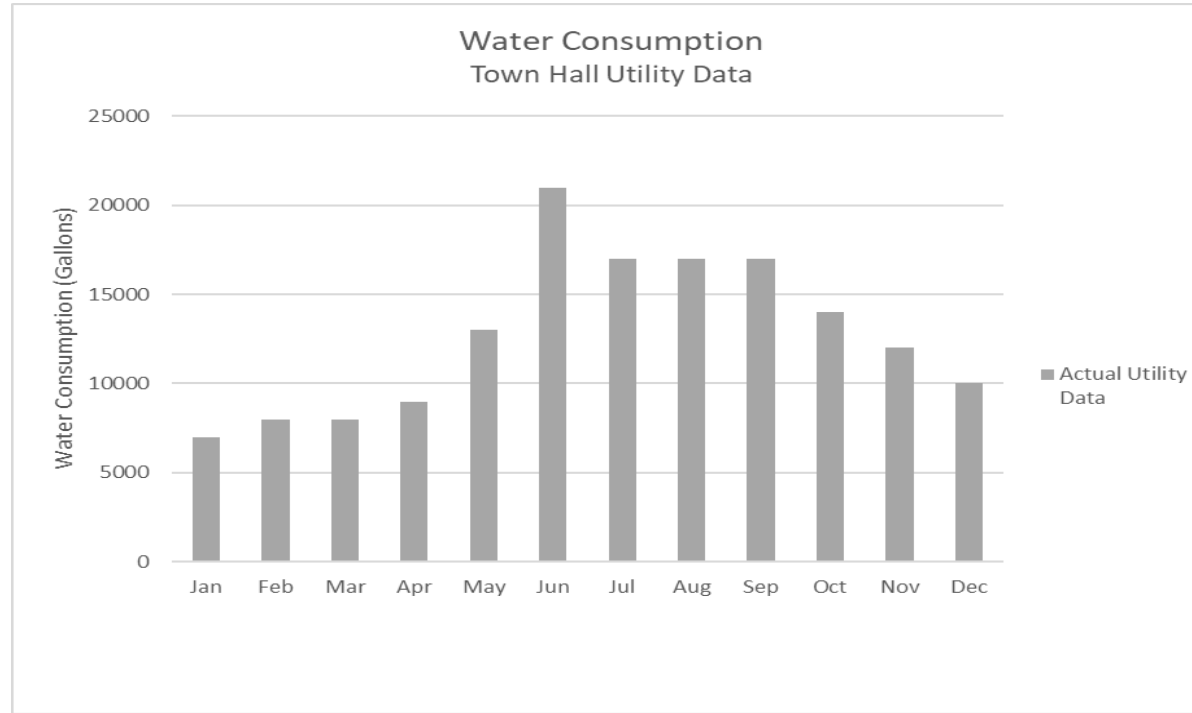

Town Hall Water Consumption (gal)			
	Actual Utility Data	Calibrated Model	% Error
Annual	155734	155731	0%



CENTURY CENTER



SIMULATED ENERGY SUMMARY

Century Center Energy Consumption Profile		
End Use	Energy Consumption (kBTU/yr)	Percent of Total
Heating	848,026	42.7%
Cooling	224,216	11.3%
Fans/Pumps	548,968	27.6%
Lighting	203,910	10.3%
DHW	13,420	0.7%
Plug Loads / Other	147,747	7.4%
Total	1,986,287	100%
Conditioned Area (sf)	19,912	
Energy Use Intensity (kBTU/sf/yr)	99.75	



ELECTRICITY

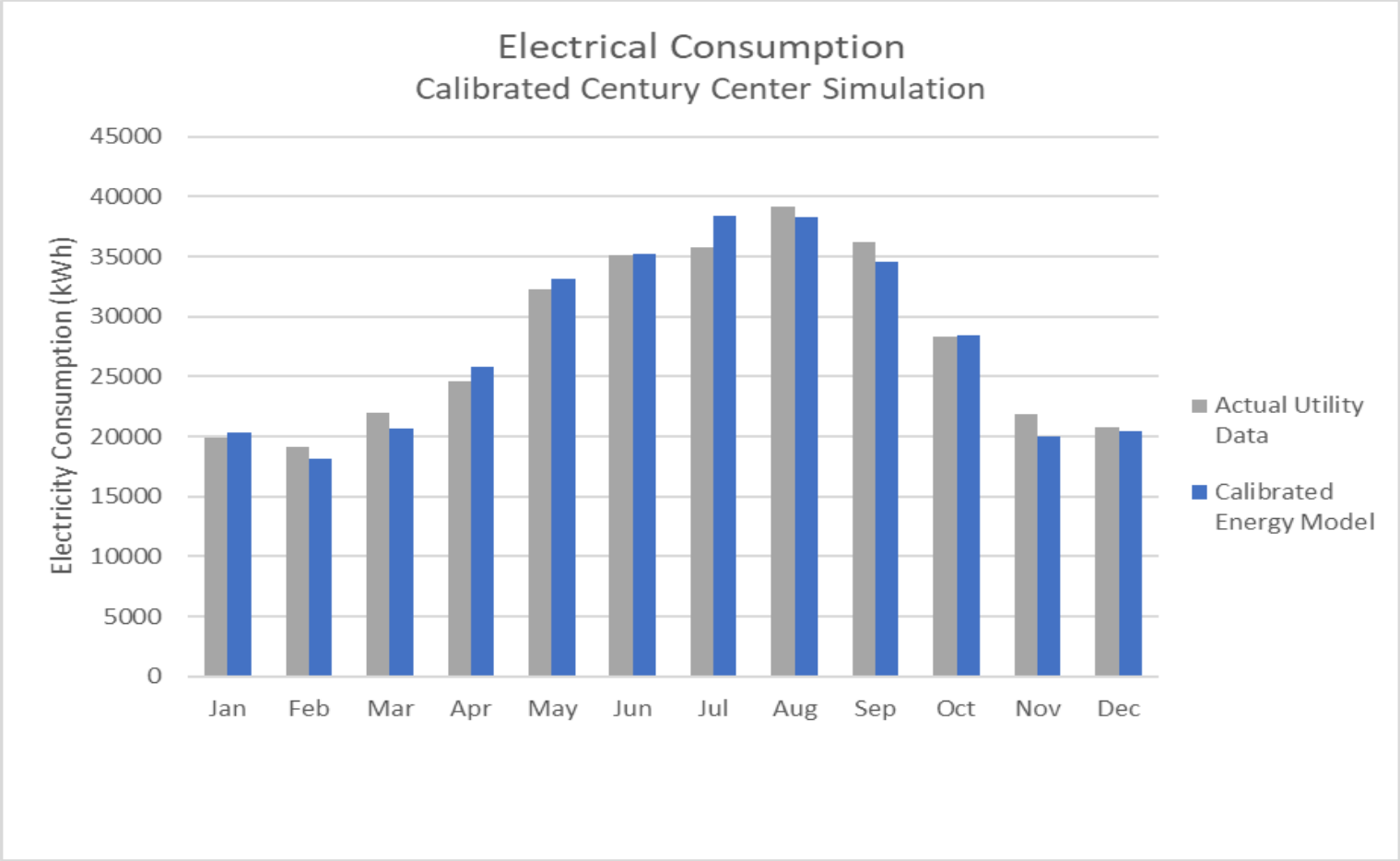

NATURAL GAS

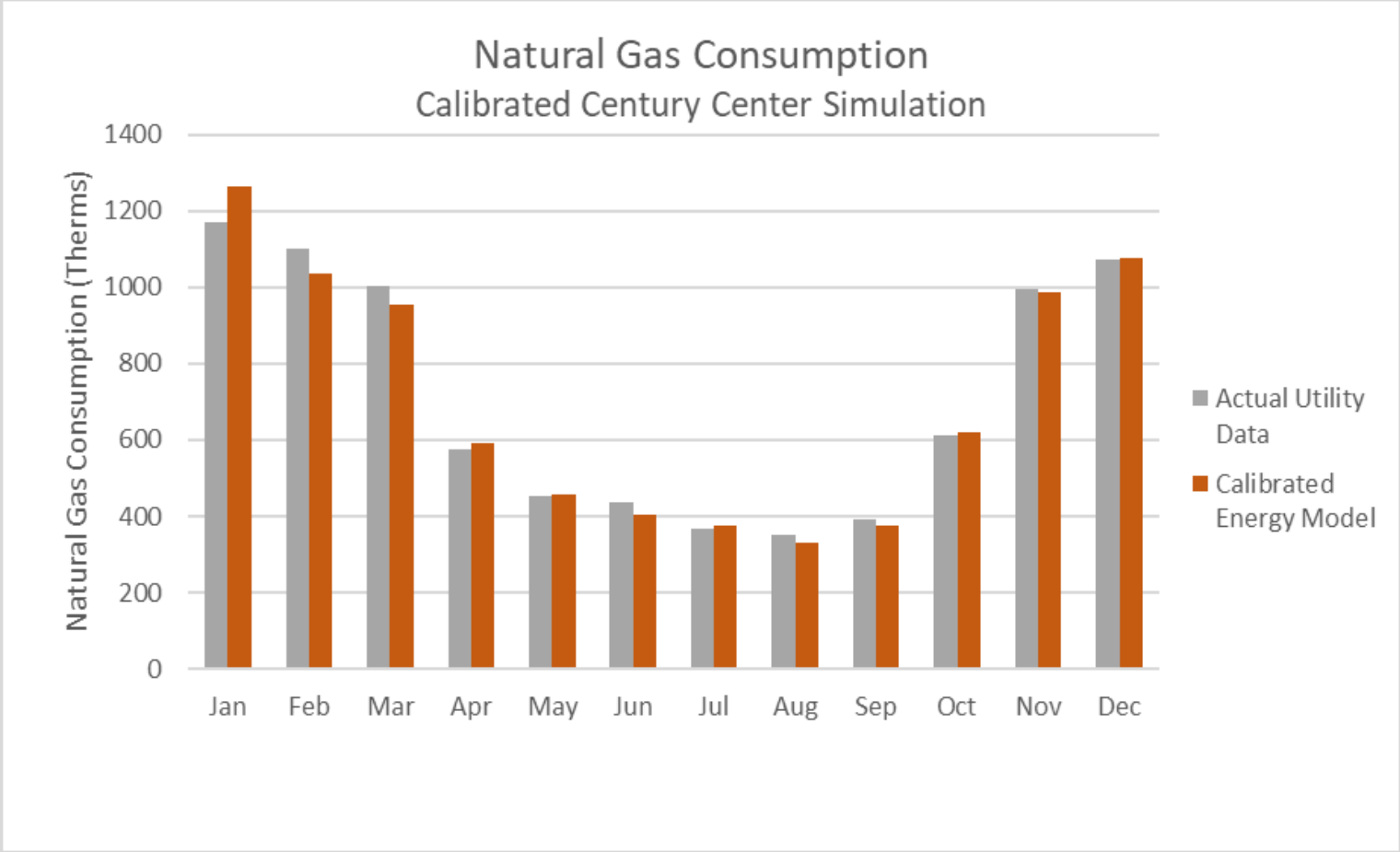

WATER

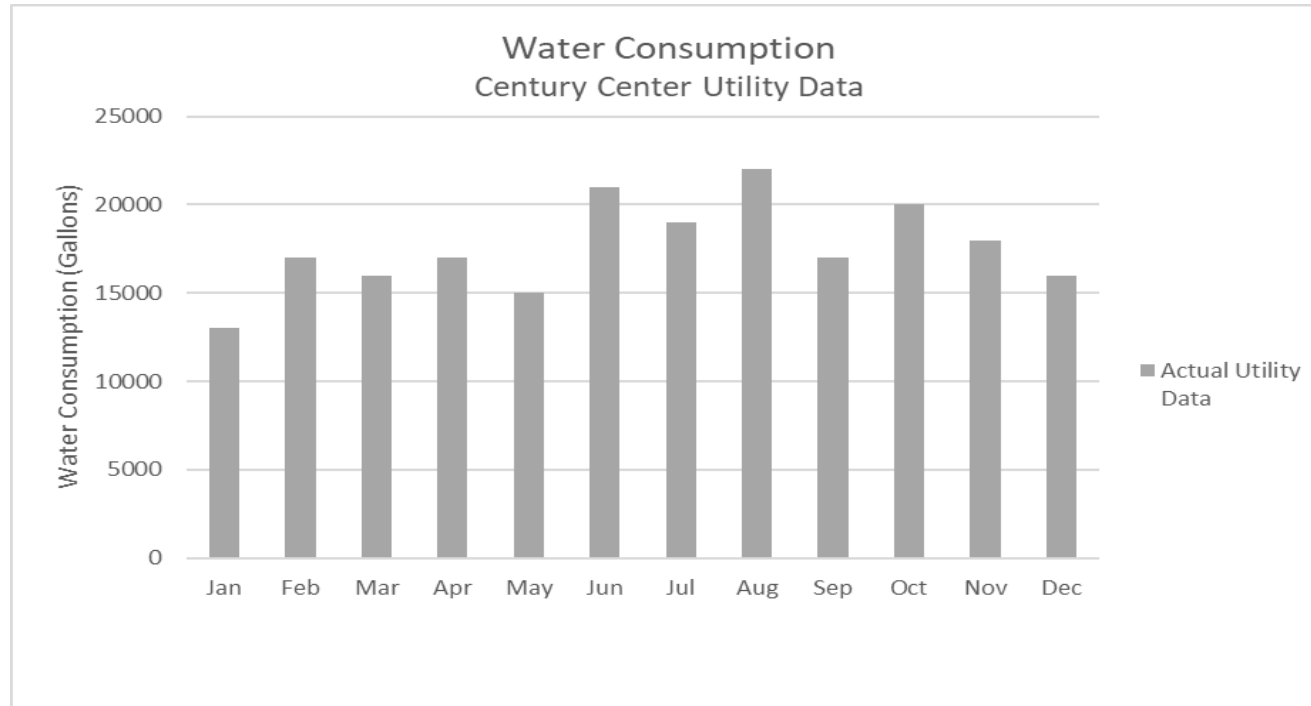

Century Center Water Consumption (gal)			
	Actual Utility Data	Calibrated Model	% Error
Annual	219416	219264	0%



PUBLIC WORKS



SIMULATED ENERGY SUMMARY

Public Works Energy Consumption Profile		
End Use	Energy Consumption (kBTU/yr)	Percent of Total
Heating	306,672	44.3%
Cooling	62,858	9.1%
Fans	36,683	5.3%
Lighting	54,922	7.9%
DHW/Carwash/Generator	30,900	4.5%
Office Equipment	15,861	2.3%
Server	15,040	2.2%
Air Compressor	24,088	3.5%
Shop/Site Equipment	11,495	1.7%
Currently Unaccounted	133,601	19.3%
Total	692,120	100%
Conditioned Area (sf)	6,300	
Energy Use Intensity (kBTU/sf/yr)	109.9	



ELECTRICITY

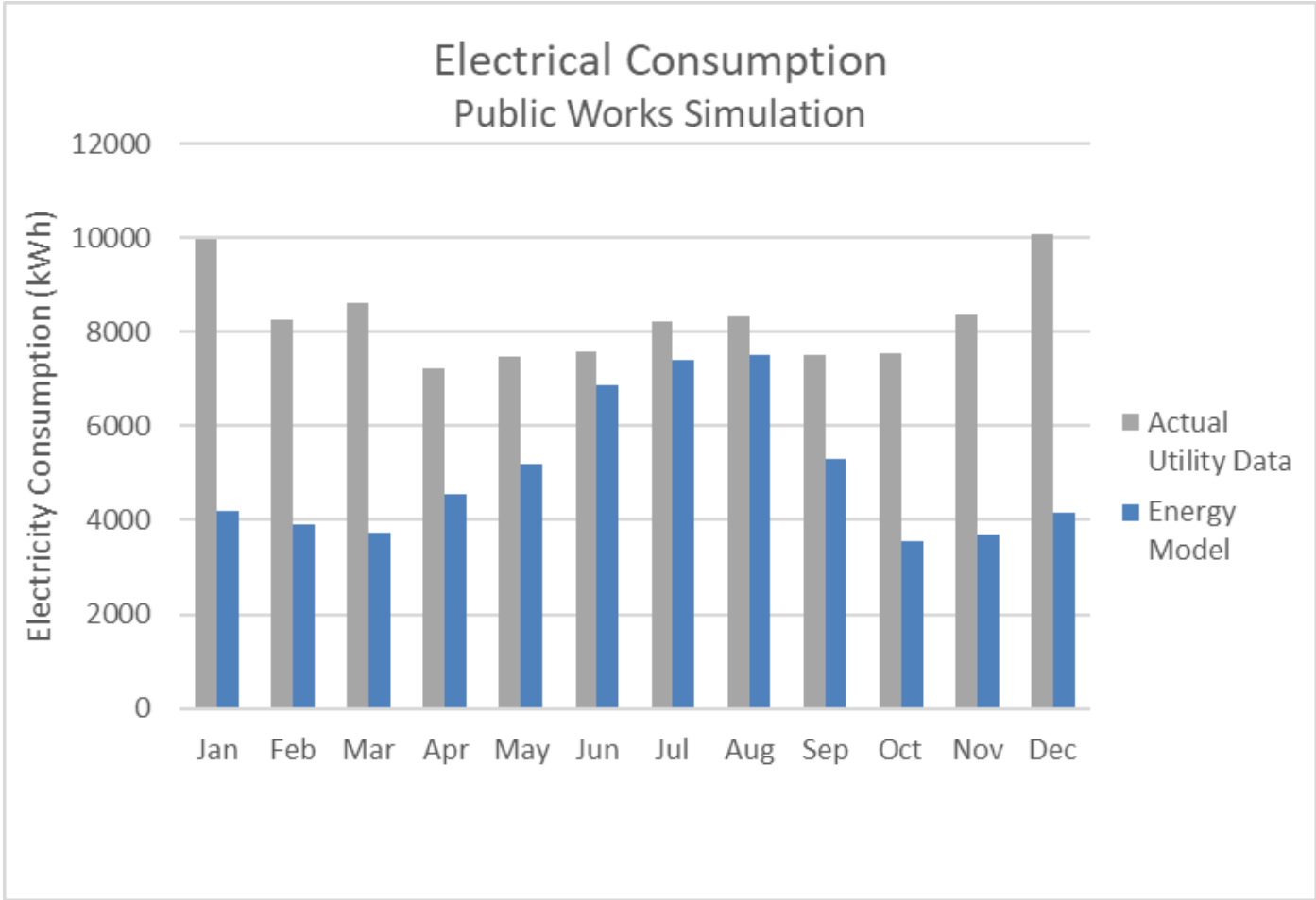

NATURAL GAS

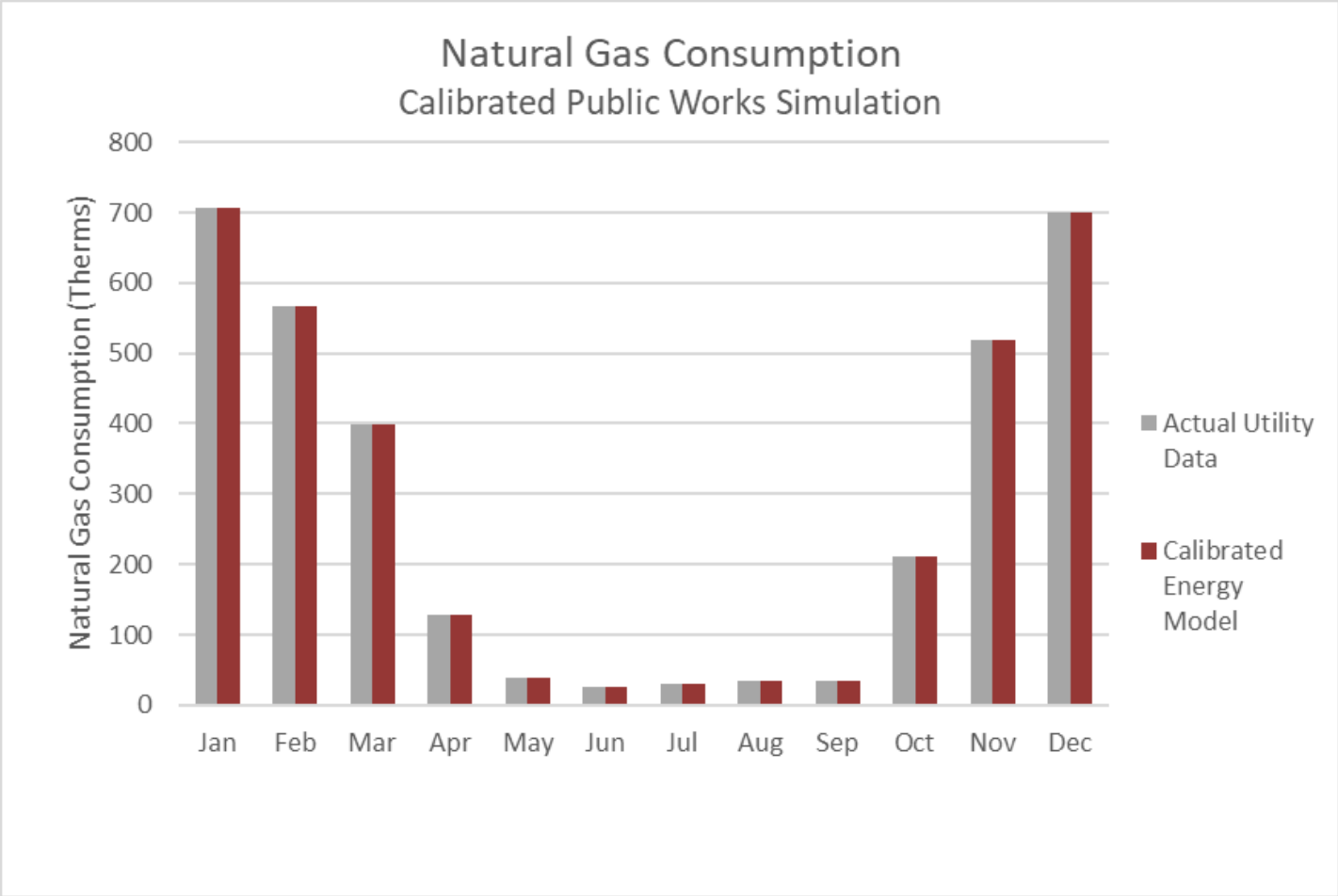

WATER

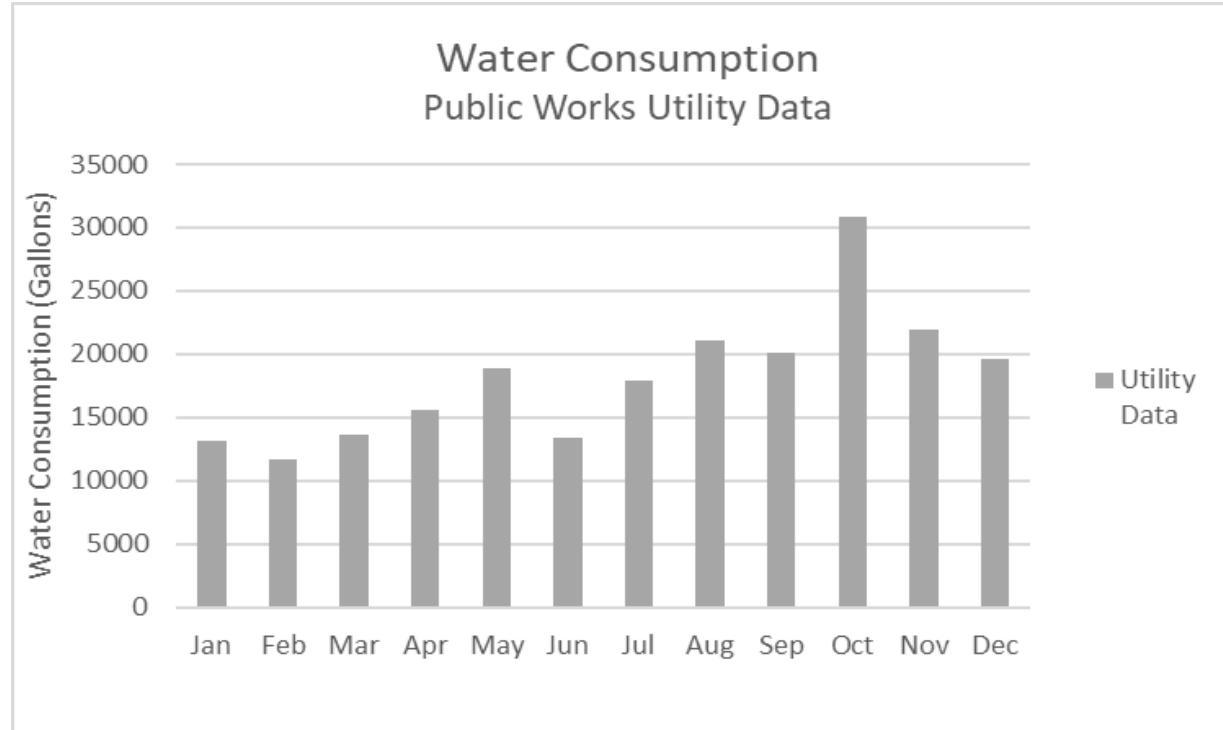

Public Works Water Consumption (Gallons)			
Period	Actual Utility Data	Calibrated Model	% Error
Annual	217948	216000	1%



DEFINING NET ZERO TOWN OF CARRBORO

Town Hall
Century Center
Public Works



DEFINING "NET-ZERO"

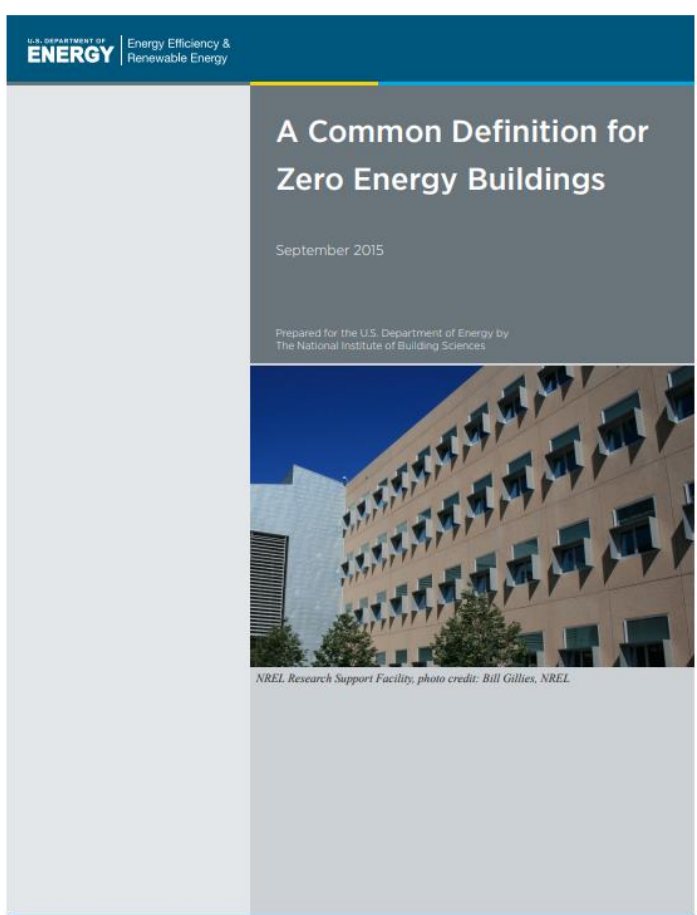
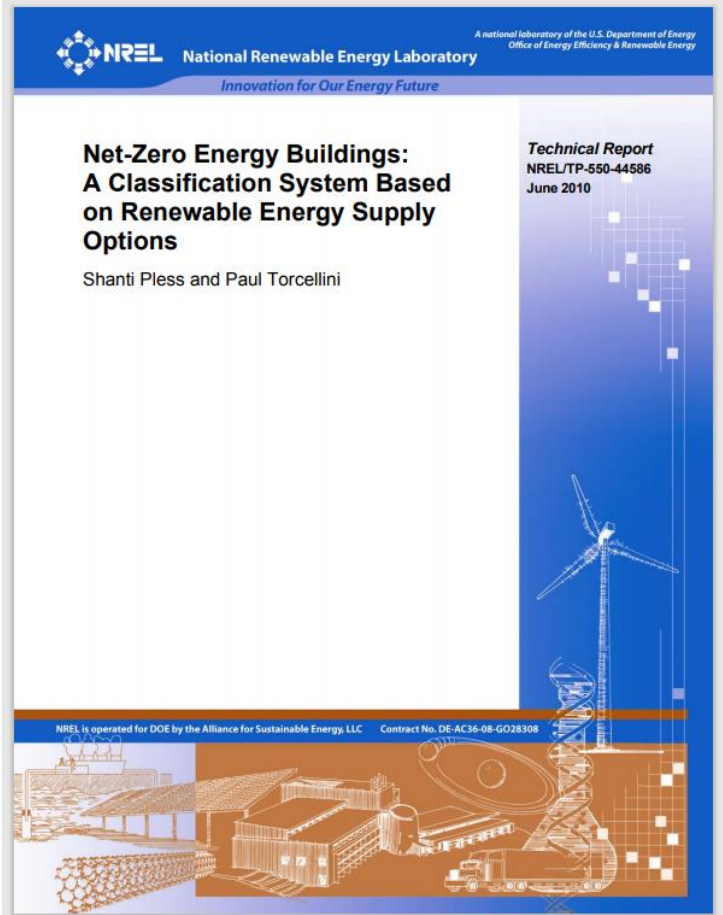

DEFINING THE METRIC

- Net-Zero...
- Option 1: Site Energy
 - Energy usage as seen on utility bills offset by renewables
- Option 2: Source Energy
 - Considers inefficiencies introduced by power plants and transmission
- Option 3: Greenhouse Gas Emissions
 - Focuses on atmospheric pollutants rather than fossil fuels themselves
- Option 4: Energy Cost
 - Based on utility costs. May not apply to the Climate Action Plan



DEFINING THE BOUNDARY

- Renewable Energy is Generated...
- Option A: Within the Building Footprint
 - e.g. solar panels on the building's roof
- Option B: Within the Property Boundary
 - e.g. panels on the building's roof and on a separate parking canopy
- Option C: Off Site
 - Imported to site, e.g. wood chips shipped to the site for building heat
 - Generated off site, e.g. PV panels on Town-owned Property
- Option D: By Others (RECs)
 - Carbon offsets can be purchased to supplement other strategies



IMPLICATIONS

- **Option 1: Net-Zero Site Energy**
 - Favors using electricity over natural gas
- **Option 2: Net-Zero Source Energy**
 - Natural gas vs electricity comparison requires analysis
- **Option 3: Net-Zero GHG Emissions**
 - Favors using natural gas over electricity
- **Option 4: Net-Zero Energy Cost**
 - Natural gas vs electricity comparison requires analysis



NEXT STEPS

- Settle on Net Zero Definition
- Design Building Improvements
 - Must first meet basic safety, health, and comfort needs
 - Incorporate changes in space usage
 - Preserve historic quality
 - Pursue efficiency upgrades toward the Net Zero goal
 - Minimize energy consumption
 - Provide the balance with renewable generation

QUESTIONS?

A RESOLUTION FOR ADOPTING A NET ZERO DEFINITION FOR THE TOWN OF
CARRBORO BUILDINGS

WHEREAS, the Town Council received a Net Zero Buildings report and presentation at the December 1, 2020 Town Council Meeting by the Town's consultant, Sud Associates, P.A., and subsequently discussed the Net Zero Buildings metric and boundary options presented; and

WHEREAS, the Environmental Advisory Board (EAB) received the same presentation on January 11, 2021 and have submitted the attached hereto comments; and

WHEREAS, the Town Council and the EAB are in agreement with which Net Zero Buildings definition to adopt for the Town of Carrboro; and

WHEREAS, the Town Council and the EAB agree that the approach to any Net Zero Buildings project will be to first conserve as much as possible through energy efficiency measures, then to make up the balance through renewable energy generation; and

NOW, THEREFORE, BE IT RESOLVED by the Carrboro Town Council that the following Net Zero Buildings definition be adopted for the Town of Carrboro:

Net Zero Buildings shall be evaluated using greenhouse gas emissions (GHG) as the accounting metric. Renewable energy can be generated off-site to offset GHG emissions from non-renewable energy consumption.

This definition conforms to Option 3C of the attached report.

This the 19th day of February in 2021.



TOWN OF CARRBORO

Environmental Advisory Board

301 West Main Street, Carrboro, North Carolina 27510

RECOMMENDATION

January 11, 2020

Net Zero Discussion

Motion was made by Echart and seconded by Brandon that the EAB recommends:

Defining Net Zero

- Option 3: Greenhouse Gas Emissions
- The Town will need timely and defensible data to back up greenhouse gas emissions calculations
 - Search for more granular data (Duke Energy vs. NREL)
 - Published emissions data can be out-of-date so the Town will need to make some assumptions
 - Need to capture life cycle emissions from the production and transportation of the energy, especially natural gas

Defining the Boundary

- Option C: Off Site
- Develop solar energy anywhere on the grid, provided that it is owned by the Town
- Does not need to be Town property or within Town boundaries
- Look into Town parks, covered parking lots
- At some point the Town may need to examine creative yet feasible opportunities
 - Community solar
 - Buy a stake in a larger operation in another location; invest in solar farms
- The entire Carrboro community is a system, the location of the renewables is not as important
- However, on-site solar will minimize distribution losses

Additional Comments

Energy Sources

- The EAB recommends not locking the Town into natural gas usage
 - If the Town relies on electrification, it has more control and flexibility
- The makeup of the Town's energy sources is a moving target
 - The Town will need to take future trends into account

RECs

- Some EAB members are skeptical of RECs due to the fact that some renewable projects may already be in place and would not represent new emissions reductions

Overall

- The Town needs to work towards a goal of reducing fossil fuel use
- The Town should first pursue maximizing the energy efficiency of its buildings
- Next, the energy usage of the buildings must be offset completely by renewables in order for the Town to reach its goals of 80% reduction of 2010 greenhouse gas emissions levels by 2030
- The building analysis is a great first step towards evaluating all municipal energy usage and ultimately, the community's energy usage

VOTE:

AYES: (5) Kaufman, Turner, Brandon, Schalkoff, Echart

ABSENT/EXCUSED: (1) Blanco

NOES: (0)

ABSTENTIONS: (0)

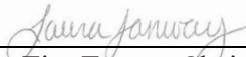

For Tim Turner, Chair (Date) 1-11-21

Town of Carrboro
Town Hall Building; Century Center Building; Public Works Complex
Defining Net Zero Metrics and Boundaries

November 23, 2020

Background

The Town of Carrboro is considering options for renovating the Town Hall, Century Center, and the Public Works complex. The Town is seeking to develop a long-term renovation strategy while at the same time addressing immediate needs which have been identified by Town Staff. As part of the renovation effort, the Town would like to work towards the energy sustainability goals set forth in the Town’s adopted Strategic Energy and Climate Action plan, which includes working toward net zero energy use.

A first step in the process of achieving a net zero energy building is to define the term “net zero” and to establish the criteria for a net zero energy building. This is more than an exercise in semantics, as the definition and criteria chosen can have significant effects on design decisions and project costs. Regardless of the definition chosen, the general approach to achieving net zero is to first conserve as much energy as is feasible, then use renewable energy to offset the remaining usage.

Defining “Net Zero”

The basic idea of a net zero energy building is that, over the course of a year, it has completely offset its energy usage by renewable energy production. Beyond this general concept, there is no single, universally accepted definition for a net zero energy building. The exact definition used for any given project is a choice made by the building owners and project team based on motivations, priorities, budget, building and site characteristics, and other constraints. The US DOE and the National Renewable Energy Laboratory (NREL) have developed a clear framework and guidance to aid owners and designers in choosing the defining criteria for their specific project.

In short, there are two decisions to be made: what metric will be used to evaluate the building’s performance (i.e. net zero what?), and what is the boundary within which renewable energy may be generated? Each of these questions is addressed below.

Defining the Metric

NREL has presented 4 options for defining the metric by which a net zero building can be evaluated: Site energy consumption, source energy consumption, greenhouse gas (GHG) emissions, and energy cost.

Option 1: Net Zero Site Energy: A net zero site energy building will offset the energy it uses on site with renewable energy. The energy consumed is seen directly on the building’s utility bills. Some owners see net zero site energy as an attractive metric primarily because it is easy to understand and its calculation does not depend on complex factors outside the boundary of the building. This metric steers designers away from natural gas as a heat or domestic hot water fuel in favor of heat pumps or even electric resistance heating.

Solar hot water is often a more attractive renewable energy source than photovoltaics under this metric.

Option 2: Net Zero Source Energy: The source energy metric considers the source of the energy used in the building. For instance, the source energy metric would account not for the electricity used in the building, but for the coal used at the power plant to produce the electricity used in the building. This metric is favored by owners whose primary motivation is to conserve the Earth's fossil-based energy sources and to reduce the environmental damage associated with the extraction of these fuels. Using this approach largely levels the field when comparing natural gas heating versus electric heat pumps.

Option 3: Net Zero GHG Emissions: This metric is based on the GHG emissions associated with the energy used in the building rather than the energy itself. For instance, the GHG emissions metric would account not for the electricity used in the building, but rather for the airborne pollution generated by the power plant as it produces the electricity used in the building. A net zero GHG building might also be called a "carbon neutral" building. Net zero GHG emissions is chosen by owners whose primary motivation is to mitigate climate change. This metric favors the use of natural gas over electricity use, and places high value on producing renewable electricity (e.g. photovoltaic panels).

Option 4: Net Zero Energy Cost: A net zero energy cost building will offset the building's energy cost over the course of a year with renewable energy sold to the grid or other users. This metric is perhaps the simplest to understand, but it may not fit with the Town's Climate Action Plan. The most attractive systems and fuel types under this metric are variable, depending on the comparative market rates of the different fuels.

Defining the Boundary

Any net zero building will require renewable energy either to power the building directly or (more likely) to offset the building's consumption of non-renewable energy. Where this renewable energy can be generated in order to count towards this offset is determined by the building owners and project team. NREL has presented 4 options, in order of decreasing constraint: building footprint generation, building site generation, imported renewables, and purchased generation.

Option A: Building Footprint Generation: This option applies the constraint that all renewable energy must be generated within the footprint of the building itself. A common example of this would be PV panels installed on the building's roof.

Option B: Building Site Generation: Renewable energy may be generated anywhere within the property lines of the net zero building. Under this option, for example, a building may have PV panels on its roof as well as on the ground or on an on-site parking canopy.

Option C: Off Site Renewables: Under this option, renewable energy may be imported from off-site and used on-site. A typical example would be biomass or biofuels used for heating. While not explicitly stated by NREL, it is our opinion that renewable energy generated by a system owned by the building owner and located on land which is owned by the building owner (though not on the building site) would qualify under Option C. An example would be PV panels located on a Town-owned park. This option simply expands options for renewable generation, it does not exclude the possibility that some energy may still be generated on the building or the building site.

Option D: Purchased Generation: This option allows renewable energy to be generated by others and

purchased by the building. This is often done in the form of Renewable Energy Credits (RECs). In this case the renewable energy itself is not necessarily used in the building, but the offsets created by the renewable energy are purchased and claimed by the building owners. Under this option, each of the previous three options may be included in the total mix of generation possibilities.

HVAC UPGRADE CONCEPTS AND RECOMMENDATIONS TOWN OF CARRBORO

Town Hall

Century Center

Public Works



STUDY PROCESS

- Energy Analysis
 - Study Facility Documents
 - Analyze Utility Data
 - Perform Site Visits
 - Research Building Use and Schedules
 - Research Building Equipment
 - Create Energy Simulations
 - Create Water Usage Spreadsheet Models
 - Calibrate Energy Simulations and Water Models
- Net Zero Consulting
 - Produce guidance material for Net Zero strategies and definitions
 - Provide general recommendations for moving toward Net Zero at each facility



PRESENTATIONS

- **10-21-2020 – TOC Facilities Committee**
 - Presented on the energy modeling process and results
- **12-1-2020 – TOC Town Council**
 - Presented on the energy modeling process and results
 - Presented on Net Zero definitions to aid council in choosing a Net Zero metric and boundary
- **1-11-2021 – TOC Environmental Advisory Board**
 - Presented on Net Zero definitions to allow EAB to advice Town Council



CENTURY CENTER

- **Keep existing system types (HW, CHW)**
 - Allows reuse of existing piping and ducting
 - Boiler is new, highly efficient
 - HW and CHW enables flexibility, effectiveness, and efficiency
 - Use of natural gas boiler does not aid goal of electrification
- **Improve Operation**
 - Apply strategies to save natural gas and electricity
 - Address extended hours areas separately
- **Equipment upgrades**
 - As chiller is slated for replacement, consider heat recovery chiller as an option
 - Aids goal of electrification by displacing some gas heat with electrical “waste heat”



TOWN HALL

- Complete redesign of systems
 - Electricity based systems
 - Consider new occupancy types and schedules
 - State of the art efficiency in equipment and strategies
 - VRF AHUs w/ VAV boxes one possible option



PUBLIC WORKS

- Focus first on system operation
 - Make the most of existing systems
- Upgrade equipment as appropriate
 - Select system types tailored to space needs
 - Continue goal of electrification
 - State of the art efficiency in equipment for new spaces



MOVING TOWARD NET ZERO

- Conserve first
 - Efficiency upgrades and no-cost/low-cost solutions
- Renewable energy
 - Solar PV the most probable primary solution
 - Some or most generation will likely need to be off-site
 - Century Center has almost no space other than the roof
 - Town Hall has several on-site options, but will likely need to supplement
- Economy of scale
 - Larger, simpler systems more cost effective than small scattered systems
 - Consider TOC as a single entity as opposed to individual buildings



**CENTURY CENTER CHILLER REPLACEMENT
AND DDC CONTROLS UPGRADE**

TOWN OF CARRBORO, NORTH CAROLINA

Town of Carrboro Project ID # 20-2023

February 22, 2024

**SUD ASSOCIATES, P.A.
CONSULTING ENGINEERS
DURHAM, NORTH CAROLINA
License No. C-0315**

CENTURY CENTER CHILLER REPLACEMENT AND DDC CONTROLS UPGRADE

TOWN OF CARRBORO, NORTH CAROLINA

Town of Carrboro Project ID # 20-2023

Divisions 01, 07, and 23



Feb 22, 2024

SUD ASSOCIATES, P.A.
Consulting Engineers
License No. C-0315
1813 Chapel Hill Road
Durham, North Carolina 27707
(919) 493-5277

CENTURY CENTER CHILLER REPLACEMENT AND DDC CONTROLS UPGRADE

TOWN OF CARRBORO, NORTH CAROLINA

Town of Carrboro Project ID # 20-2023

Division 26

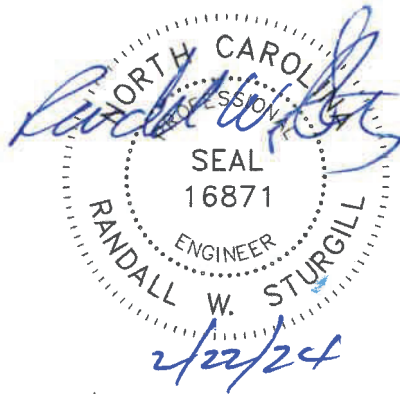

Sturgill Engineering, P.A.
License Number C-1210
1 South Main Street
Lexington, NC 27292
(336) 238-1249

TABLE OF CONTENTS

CENTURY CENTER CHILLER REPLACEMENT & DDC CONTROLS UPGRADE TOWN OF CARRBORO

ADVERTISEMENT FOR BIDS

NOTICE TO BIDDERS

GENERAL CONDITIONS

SUPPLEMENTARY GENERAL CONDITIONS

FORM OF PROPOSAL

MWBE REQUIREMENTS AND PARTICIPATION FORM

DIVISION 01 – GENERAL REQUIREMENTS

Section 01 01 00 – Summary of the Work	7 Pages
Section 01 21 00 – Allowances	3 Pages
Section 01 22 00 – Unit Prices	2 Pages
Section 01 23 00 – Alternates	2 Pages
Section 01 29 00 – Payment Procedures	2 Pages
Section 01 41 00 – Project Coordination	3 Pages
Section 01 42 16 – Definitions and Standards	5 Pages
Section 01 65 00 – Shop Drawings, Product Data, and Samples	6 Pages
Section 01 67 00 – Products and Substitutions	6 Pages
Section 01 73 29 – Cutting and Patching	3 Pages

DIVISION 07 – THERMAL AND MOISTURE PROTECTION

Section 07 84 13 – Penetration Firestopping	3 Pages
---	---------

DIVISION 23 – HEATING, VENTILATING, AND AIR CONDITIONING (HVAC)

Section 23 05 10 – Basic Mechanical Requirement	8 Pages
Section 23 05 20 – Piping Specialties	4 Pages
Section 23 05 23 – General Duty Valves for HVAC	5 Pages
Section 23 05 29 – Supports, Anchors and Vibration Isolation	8 Pages
Section 23 05 30 – Electrical Provisions for Mechanical Work	6 Pages
Section 23 05 45 – Mechanical Related Work	4 Pages
Section 23 05 71 – Adjustable Speed Drives	7 Pages
Section 23 05 90 – Mechanical Painting and Identification	4 Pages
Section 23 05 94 – Testing and Balancing of HVAC Systems	5 Pages
Section 23 07 00 – HVAC Insulation	7 Pages
Section 23 09 23 – DDC System for HVAC	16 Pages
Section 23 20 10 – Water Piping Systems and Hydronic Specialties	3 Pages
Section 23 21 23 – Hydronic Pumps	3 Pages
Section 23 21 60 – Pipes and Pipe Fittings	5 Pages
Section 23 25 00 – Water Conditioning	3 Pages
Section 23 64 23 – Variable Speed Air Cooled Scroll Water Chillers	9 Pages
Installation Instructions for 30RAP Chiller	
Start-Up Checklist for 30RAP Liquid Chiller	

DIVISION 26 – ELECTRICAL

Section 26 00 00 – General Requirements	9 Pages
Section 26 00 10 – General Provisions	4 Pages
Section 26 01 11 – Conduit	5 Pages
Section 26 01 23 – Wire & Cable	4 Pages
Section 26 01 30 – Boxes	3 Pages
Section 26 01 70 – Grounding & Bonding	3 Pages
Section 26 01 90 – Supporting Devices	2 Pages
Section 26 01 95 – Electrical Identification	3 Pages
Section 26 04 41 – Enclosed Switches & ECB	3 Pages

ADVERTISEMENT FOR BIDS

Sealed proposals will be received by Town of Carrboro until 3:00 P.M., April 9, 2024, address to ATT: Bret Greene, Finance Director, Town of Carrboro, 100 Public Works Dr., Carrboro, NC 27510, for the furnishing of labor, material and equipment for the Century Center Chiller Replacement and DDC Controls Upgrade. At the same time and place, the bids will be publicly opened and read.

Bids must be sealed and clearly labeled: “Sealed Bid: Century Center Chiller Replacement and DDC Controls Upgrade” with the name of the Bidder and the North Carolina State Contractor's Registration Number, and the names of the first-tier subcontractors (general, mechanical, and electrical)

The scope of work includes:

- Relocate and install air cooled chiller that was ordered, paid for, and received by the owner.
- Demolish select existing mechanical equipment and provide new pumps, variable speed drive, etc.
- Demolish existing DDC controls and provide new BACnet IP DDC controls.
- 35 existing VAV boxes with hot water coils to remain and have their controls replaced.
- Electrical revisions required to support the mechanical changes.

Complete plans and contract documents can be obtained through the office of Sud Associates, P.A., 1813 Chapel Hill Road, Durham, NC 27707, (919) 493-5277. Contact Maria Spittler by telephone or e-mail maria@sudassociates.com during normal office hours.

Plan Deposit \$150.00 for hard copy. Electronic copy is complimentary.

A pre-bid meeting will be held on site for all interested bidders on March 12, 2024 at 2:00 P.M. Meet in Activity Room 2/3 on site (100 N. Greensboro Street, Carrboro, NC 27510). To be considered responsive and responsible bidders, the prime contractor and first tier subcontractors (general, mechanical and electrical) shall attend either the pre-bid conference or a site visit at a later date scheduled by the Owner, or both. Attendance must be documented by the Engineers or the Owner. Without attending one of these, the contractor's bid will not be accepted.

An open public meeting will be held in conjunction with the pre-bid conference to identify preferred brand alternates and their performance standards pertinent to this project. In accordance with GS133-3, Section 64. (C) procedures the following preferred brand items are being considered as Alternates by the owner for this project:

A. Owner Preferred Alternate No. OP-M1: Provide DDC controls by Honeywell Building Technologies, subject to compliance with the requirements of the specifications.

A copy of pertinent sections of the performance standards may be obtained by contacting the designer at the address or phone number noted herein.

The Town of Carrboro reserves the unqualified right to waive informalities and reject any and all proposals.

Signed: Town of Carrboro
 Mr. Keith Berger
 Deputy Public Works Director
 Public Works Department
 100 Public Works Drive
 Carrboro, NC 27510
 Telephone: (919) 918-7432

NOTICE TO BIDDERS

CENTURY CENTER CHILLER REPLACEMENT AND DDC CONTROLS UPGRADE

TOWN OF CARRBORO
100 N. GREENSBORO ST., CARRBORO, NC 27510

Town of Carrboro's Project No. 20-2023

Sealed proposals will be received by the Town of Carrboro until 3:00 P.M., April 9, 2024, address to ATT: Brett Greene, Finance Director, Carrboro Town Hall, 301 West Main Street, Carrboro, NC 27510, to install an air-cooled chiller, provide two pumps, replace DDC control system, specified ancillaries, and electrical work to support the HVAC work at Century Center, 100 N. Greensboro St., Carrboro, NC 27510. At the same time and place, the bids will be opened and read.

Hard copies of complete specifications and plans for this project can be obtained from Sud Associates, P.A., 1813 Chapel Hill Road, Durham, NC 27707 during normal office hours by those qualified and who will make a bid, upon deposit of one hundred and fifty dollars (\$150.00) in cash or certified check. The full deposit will be returned to contractors submitting bids provided all documents are returned in good condition within ten (10) days after the bid date. The full plan deposit will be returned to contractors not submitting bids provided all documents are returned in good condition at least ten (10) days prior to the bid date. It is the bidder's responsibility to thoroughly examine the specifications and include all items that are required to be furnished.

To receive a complimentary electronic copy of contract documents and to be placed on the distribution list, please send the following information to Maria Spittler, e-mail: maria@sudassociates.com. Name and e-mail of individual, Company Name, Address, Web Site, Telephone Number and Fax Number.

All contractors are hereby notified that they must have a proper license as required under the NC state laws governing their respective trades.

Inquiries should be directed to Dixie Davis, PE, Sud Associates at 1813 Chapel Hill Rd, Durham NC 27707, phone 919-493-5277, email ddavis@sudassociates.com.

A pre-bid meeting will be held on site for all interested bidders on March 12, 2024, at 2:00 P.M. Meet in Activity Room 2/3 on site (100 N. Greensboro Street, Carrboro, NC 27510). To be considered responsive and responsible bidders, the prime contractor and first tier subcontractors (general, mechanical and electrical) shall attend either the pre-bid conference or a site visit at a later date scheduled by the Owner, or both. Attendance must be documented by the Engineers or the Owner. Without attending one of these, the contractor's bid will not be accepted.

An open public meeting will be held in conjunction with the pre-bid conference to identify preferred brand alternates and their performance standards pertinent to this project. In accordance with GS133-3, Section 64. (C) procedures the following preferred brand items are being considered as Alternates by the owner for this project:

A. Owner Preferred Alternate No. OP-M1: Provide DDC controls by Honeywell Building Technologies, subject to compliance with the requirements of the specifications.

A copy of pertinent sections of the performance standards may be obtained by contacting the designer at the address or phone number noted herein.

The Owner reserves the right to reject any or all bids and to waive informalities.

Designer:

SUD ASSOCIATES, P.A.
Consulting Engineers
1813 Chapel Hill Road
Durham, North Carolina 27707
Telephone: 919/493-5277
FAX: 919/493-5549

Owner:

Town of Carrboro
Mr. Keith Berger
100 Public Works Drive
Carrboro, NC 27510
Telephone: 919/918-7432

**INSTRUCTIONS TO BIDDERS
AND
GENERAL CONDITIONS OF THE CONTRACT**

STANDARD FORM FOR CONSTRUCTION PROJECTS

INSTRUCTIONS TO BIDDERS

For a proposal to be considered it must be in accordance with the following instructions:

1. PROPOSALS

Proposals must be made in strict accordance with the Form of Proposal provided therefor, and all blank spaces for bids, alternates, and unit prices applicable to bidder's work shall be properly filled in. When requested alternates are not bid, the proposer shall so indicate by the words "No Bid". Any blanks shall also be interpreted as "No Bid". The bidder agrees that bid on Form of Proposal detached from specifications will be considered and will have the same force and effect as if attached thereto. Photocopied or faxed proposals will not be considered. Numbers shall be stated both in writing and in figures for the base bids and alternates. If figures and writing differ, the written number will supersede the figures.

Any modifications to the Form of Proposal (including alternates and/or unit prices) will disqualify the bid and may cause the bid to be rejected.

The bidder shall fill in the Form of Proposal as follows:

- a. If the documents are executed by a sole owner, that fact shall be evidenced by the word "Owner" appearing after the name of the person executing them.
- b. If the documents are executed by a partnership, that fact shall be evidenced by the word "Co-Partner" appearing after the name of the partner executing them.
- c. If the documents are executed on the part of a corporation, they shall be executed by either the president or the vice president and attested by the secretary or assistant secretary in either case, and the title of the office of such persons shall appear after their signatures. The seal of the corporation shall be impressed on each signature page of the documents.
- d. If the proposal is made by a joint venture, it shall be executed by each member of the joint venture in the above form for sole owner, partnership or corporation, whichever form is applicable.
- e. All signatures shall be properly witnessed.
- f. If the contractor's license of a bidder is held by a person other than an owner, partner or officer of a firm, then the licensee shall also sign and be a party to the proposal. The title "Licensee" shall appear under his/her signature.

Proposals should be addressed as indicated in the Advertisement for Bids and be delivered, enclosed in an opaque sealed envelope, marked "Proposal" and bearing the title of the work, name of the bidder, and the contractor's license number of the bidder. Bidders should clearly mark on the outside of the bid envelope which contract(s) they are bidding.

Bidder shall identify on the bid, the minority businesses that will be utilized on the project with corresponding total dollar value of the bid and affidavit listing good faith efforts or an affidavit indicating work under contract will be self-performed, as required by G.S. 143-128.2(c) and G.S. 143-128.2(f). Failure to comply with these requirements is grounds for rejection of the bid.

For projects bid in the single-prime alternative, the names and license numbers of major subcontractors shall be listed on the proposal form.

It shall be the specific responsibility of the bidder to deliver his bid to the proper official at the selected place and prior to the announced time for the opening of bids. Later delivery of a bid for any reason, including delivery by any delivery service, shall disqualify the bid.

Unit prices quoted in the proposal shall include overhead and profit and shall be the full compensation for the contractor's cost involved in the work. See General Conditions, Article 19c-1.

2. EXAMINATION OF CONDITIONS

It is understood and mutually agreed that by submitting a bid the bidder acknowledges that he has carefully examined all documents pertaining to the work, the location, accessibility and general character of the site of the work and all existing buildings and structures within and adjacent to the site, and has satisfied himself as to the nature of the work, the condition of existing buildings and structures, the conformation of the ground, the character, quality and quantity of the material to be encountered, the character of the equipment, machinery, plant and any other facilities needed preliminary to and during prosecution of the work, the general and local conditions, the construction hazards, and all other matters, including, but not limited to, the labor situation which can in any way affect the work under the contract, and including all safety measures required by the Occupational Safety and Health Act of 1970 and all rules and regulations issued pursuant thereto. It is further mutually agreed that by submitting a proposal the bidder acknowledges that he has satisfied himself as to the feasibility and meaning of the plans, drawings, specifications and other contract documents for the construction of the work and that he accepts all the terms, conditions and stipulations contained therein; and that he is prepared to work in cooperation with other contractors performing work on the site.

Reference is made to contract documents for the identification of those surveys and investigation reports of subsurface or latent physical conditions at the site or otherwise affecting performance of the work which have been relied upon by the designer in preparing the documents. The owner will make copies of all such surveys and reports available to the bidder upon request.

Each bidder may, at his own expense, make such additional surveys and investigations as he may deem necessary to determine his bid price for the performance of the work. Any on-site investigation shall be done at the convenience of the owner. Any reasonable request for access to the site will be honored by the owner.

3. BULLETINS AND ADDENDA

Any addenda to specifications issued during the time of bidding are to be considered covered in the proposal and in closing a contract they will become a part thereof. It shall be the bidder's responsibility to ascertain prior to bid time the addenda issued and to see that his bid includes any changes thereby required.

Should the bidder find discrepancies in, or omission from, the drawings or documents or should he be in doubt as to their meaning, he shall at once notify the designer who will send written instructions in the form of addenda to all bidders. Notification should be no later than seven (7) days prior to the date set for receipt of bids. Neither the owner nor the designer will be responsible for any oral instructions.

All addenda should be acknowledged by the bidder(s) on the Form of Proposal. However, even if not acknowledged, by submitting a bid, the bidder has certified that he has reviewed all issued addenda and has included all costs associated within his bid.

4. BID SECURITY

Each proposal shall be accompanied by a cash deposit or a certified check drawn on some bank or trust company insured by the Federal Deposit Insurance Corporation, or a bid bond in an amount equal to not less than five percent (5%) of the proposal, said deposit to be retained by the owner as liquidated damages in event of failure of the successful bidder to execute the contract within ten (10) days after the award or to give satisfactory surety as required by law (G.S. 143-129).

Bid bond shall be conditioned that the surety will, upon demand, forthwith make payment to the obligee upon said bond if the bidder fails to execute the contract. The owner may retain bid securities of any bidder(s) who may have a reasonable chance of award of contract for the full duration of time stated in the Notice to Bidders. Other bid securities may be released sooner, at the discretion of the owner. All bid securities (cash or certified checks) shall be returned to the bidders promptly after award of contracts, and no later than seven (7) days after expiration of the holding period stated in the Notice to Bidders. Standard Form of Bid Bond is included in these specifications and shall be used.

5. RECEIPT OF BIDS

Bids shall be received in strict accordance with requirements of the General Statutes of North Carolina. Bid security shall be required as prescribed by statute. Prior to the closing of the bid, the bidder will be permitted to change or withdraw his bid. Guidelines for opening of public construction bids are available from the State Construction Office.

6. OPENING OF BIDS

Upon opening, all bids shall be read aloud. Once bidding is closed, there shall not be any withdrawal of bids by any bidder and no bids may be returned by the designer to any bidder. After the opening of bids, no bid may be withdrawn, except under the provisions of General Statute 143-129.1, for a period of thirty days unless otherwise specified. Should the successful bidder default and fail to execute a contract, the contract may be awarded to the next lowest and responsible bidder. The owner reserves the unqualified right to reject any and all bids. Reasons for rejection may include, but shall not be limited to, the following:

- a. If the Form of Proposal furnished to the bidder is not used or is altered.
- b. If the bidder fails to insert a price for all bid items, alternate and unit prices requested.
- c. If the bidder adds any provisions reserving the right to accept or reject any award.
- d. If there are unauthorized additions or conditional bids, or irregularities of any kind which tend to make the proposal incomplete, indefinite or ambiguous as to its meaning.
- e. If the bidder fails to complete the proposal form where information is requested so the bid may be properly evaluated by the owner.
- f. If the unit prices contained in the bid schedule are unacceptable to the owner and the State Construction Office.
- g. If the bidder fails to comply with other instructions stated herein.

7. BID EVALUATION

The award of the contract will be made to the lowest responsible bidder as soon as practical. The owner may award on the basis of the base bid and any alternates the owner chooses.

Before awarding a contract, the owner may require the apparent low bidder to qualify himself to be a responsible bidder by furnishing any or all of the following data:

- a. The latest financial statement showing assets and liabilities of the company or other information satisfactory to the owner.
- b. A listing of completed projects of similar size.
- c. Permanent name and address of place of business.
- d. The number of regular employees of the organization and length of time the organization has been in business under present name.
- e. The name and home office address of the surety proposed and the name and address of the responsible local claim agent.
- f. The names of members of the firms who hold appropriate trade licenses, together with license numbers.
- g. If prequalified, contractor info will be reviewed and evaluated comparatively to submitted prequalification package.

Failure or refusal to furnish any of the above information, if requested, shall constitute a basis for disqualification of any bidder.

In determining the lowest responsible, responsive bidder, the owner shall take into consideration the bidder's compliance with the requirements of G.S. 143-128.2(c), the past performance of the bidder on construction contracts for the State with particular concern given to completion times, quality of work, cooperation with other contractors, and cooperation with the designer and owner. Failure of the low bidder to furnish affidavit and/or documentation as required by G.S. 143-128.2(c) shall constitute a basis for disqualification of the bid.

Should the owner adjudge that the apparent low bidder is not the lowest responsible, responsive bidder by virtue of the above information, said apparent low bidder will be so notified and his bid security shall be returned to him.

8. PERFORMANCE BOND

The successful bidder, upon award of contract, shall furnish a performance bond in an amount equal to 100 percent of the contract price. See Article 35, General Conditions.

9. PAYMENT BOND

The successful bidder, upon award of contract, shall furnish a payment bond in an amount equal to 100 percent of the contract price. See Article 35, General Conditions.

10. PAYMENTS

Payments to the successful bidders (contractors) will be made on the basis of monthly estimates. See Article 31, General Conditions.

11. PRE-BID CONFERENCE

Prior to the date set for receiving bids, the Designer may arrange and conduct a Pre-Bid Conference for all prospective bidders. The purpose of this conference is to review project requirements and to respond to questions from prospective bidders and their subcontractors or material suppliers related to the intent of bid documents. Attendance by prospective bidders shall be as required by the "Notice to Bidders".

12. SUBSTITUTIONS

In accordance with the provisions of G.S. 133-3, material, product, or equipment substitutions proposed by the bidders to those specified herein can only be considered during the bidding phase until ten (10) days prior to the receipt of bids when submitted to the Designer with sufficient data to confirm material, product, or equipment equality. Proposed substitutions submitted after this time will be considered only as potential change order.

Submittals for proposed substitutions shall include the following information:

- a. Name, address, and telephone number of manufacturer and supplier as appropriate.
- b. Trade name, model or catalog designation.
- c. Product data including performance and test data, reference standards, and technical descriptions of material, product, or equipment. Include color samples and samples of available finishes as appropriate.
- d. Detailed comparison with specified products including performance capabilities, warranties, and test results.
- e. Other pertinent data including data requested by the Designer to confirm product equality.

If a proposed material, product, or equipment substitution is deemed equal by the Designer to those specified, all bidders of record will be notified by Addendum.

GENERAL CONDITIONS OF THE CONTRACT

The use or reproduction of this document or any part thereof is authorized for and limited to use on projects of the State of North Carolina, and is distributed by, through and at the discretion of the State Construction Office, Raleigh, North Carolina, for that distinct and sole purpose.

TABLE OF CONTENTS

ARTICLE	TITLE	PAGE
1	Definitions	9
2	Intent and Execution of Documents	11
3	Clarifications and Detail Drawings	12
4	Copies of Drawings and Specifications	12
5	Shop Drawings, Submittals, Samples, Data	13
6	Working Drawings and Specifications at the Job Site	13
7	Ownership of Drawings and Specifications	14
8	Materials, Equipment, Employees	14
9	Royalties, Licenses and Patent	15
10	Permits, Inspections, Fees, Regulations	15
11	Protection of Work, Property and the Public	16
12	Sedimentation Pollution Control Act of 1973	17
13	Inspection of the Work	17
14	Construction Supervision and Schedule	18
15	Separate Contracts and Contractor Relationships	22
16	Subcontracts and Subcontractors	23
17	Contractor and Subcontractor Relationships	23
18	Designer's Status	24
19	Changes in the Work	25
20	Claims for Extra Cost	27
21	Minor Changes in the Work	29
22	Uncorrected Faulty Work	29
23	Time of Completion, Delays, Extension of Time	29
24	Partial Utilization: Beneficial Occupancy	30
25	Final Inspection, Acceptance, and Project Closeout	31
26	Correction of Work Before Final Payment	31
27	Correction of Work After Final Payment	32
28	Owner's Right to Do Work	32
29	Annulment of Contract	32
30	Contractor's Right to Stop Work or Terminate the Contract	33
31	Requests for Payments	33
32	Certificates of Payment and Final Payment	34
33	Payments Withheld	36
34	Minimum Insurance Requirements	36
35	Performance Bond and Payment Bond	37
36	Contractor's Affidavit	38
37	Assignments	38
38	Use of Premises	38
39	Cutting, Patching and Digging	38
40	Utilities, Structures, Signs	38
41	Cleaning Up	40
42	Guarantee	41

43	Codes and Standards	41
44	Indemnification	41
45	Taxes	41
46	Equal Opportunity Clause	42
47	Employment of the Handicapped	42
48	Asbestos-Containing Materials (ACM)	43
49	Minority Business Participation	43
50	Contractor Evaluation	43
51	Gifts.....	43
52	Auditing Access to Persons and Records	44
53	North Carolina False Claims Act.....	44
54	Termination for Convenience.....	45

ARTICLE 1 - DEFINITIONS

- a. The **contract documents** consist of the Notice to Bidders; Instructions to Bidders; General Conditions of the Contract; special conditions if applicable; Supplementary General Conditions; the drawing and specifications, including all bulletins, addenda or other modifications of the drawings and specifications incorporated into the documents prior to their execution; the proposal; the contract; the performance bond; the payment bond; insurance certificates; the approval of the attorney general; and the certificate of the Office of State Budget and Management. All of these items together form the contract.
- b. The **owner** is the State of North Carolina through the agency named in the contract.
- c. The **designer(s)** are those referred to within this contract, or their authorized representatives. The Designer(s), as referred to herein, shall mean architect and/or engineer. They will be referred to hereinafter as if each were of the singular number, masculine gender.
- d. The **contractor**, as referred to hereinafter, shall be deemed to be either of the several contracting parties called the "Party of the First Part" in either of the several contracts in connection with the total project. Where, in special instances hereinafter, a particular contractor is intended, an adjective precedes the word "contractor," as "general," "heating," etc. For the purposes of a single prime contract, the term Contractor shall be deemed to be the single contracting entity identified as the "Party of the First Part" in the single Construction Contract. Any references or adjectives that name or infer multiple prime contractors shall be interpreted to mean the single prime Contractor.
- e. A **subcontractor**, as the term is used herein, shall be understood to be one who has entered into a direct contract with a contractor, and includes one who furnishes materials worked to a special design in accordance with plans and specifications covered by the contract, but does not include one who only sells or furnishes materials not requiring work so described or detailed.
- f. **Written notice** shall be defined as notice in writing delivered in person to the contractor, or to a partner of the firm in the case of a partnership, or to a member of the contracting organization, or to an officer of the organization in the case of a corporation, or sent to the last known business address of the contracting organization by registered mail.
- g. **Work**, as used herein as a noun, is intended to include materials, labor, and workmanship of the appropriate contractor.
- h. The **project** is the total construction work to be performed under the contract documents by the several contractors.
- i. **Project Expediter**, as used herein, is an entity stated in the contract documents, designated to effectively facilitate scheduling and coordination of work activities. See Article 14(f) for responsibilities of a Project Expediter. **For the purposes of a single prime contract, the single prime contractor shall be designated as the Project Expediter.**
- j. **Change order**, as used herein, shall mean a written order to the contractor subsequent to the signing of the contract authorizing a change in the contract. The change order shall be signed by the contractor, designer and the owner, and approved by the State Construction Office, in that order (Article 19).

- k. **Field Order**, as used herein, shall mean a written approval for the contractor to proceed with the work requested by owner prior to issuance of a formal Change Order. The field order shall be signed by the contractor, designer, owner, and State Construction Office.
- l. **Time of completion**, as stated in the contract documents, is to be interpreted as consecutive calendar days measured from the date established in the written Notice to Proceed, or such other date as may be established herein (Article 23).
- m. **Liquidated damages**, as stated in the contract documents [, is an amount reasonably estimated in advance to cover the consequential damages associated with the Owner's economic loss in not being able to use the Project for its intended purposes at the end of the contract's completion date as amended by change order, if any, by reason of failure of the contractor(s) to complete the work within the time specified. Liquidated damages does not include the Owner's extended contract administration costs (including but not limited to additional fees for architectural and engineering services, testing services, inspection services, commissioning services, etc.), such other damages directly resulting from delays caused solely by the contractor, or consequential damages that the Owner identified in the bid documents that may be impacted by any delay caused solely by the Contractor (e.g., if a multi-phased project-subsequent phases, delays in start other projects that are dependent on the completion of this Project, extension of leases and/or maintenance agreements for other facilities).
- n. **Surety**, as used herein, shall mean the bonding company or corporate body which is bound with and for the contractor, and which engages to be responsible for the contractor and his acceptable performance of the work.
- o. **Routine written communications between the Designer and the Contractor** are any communication other than a "request for information" provided in letter, memo, or transmittal format, sent by mail, courier, electronic mail, or facsimile. Such communications can not be identified as "request for information".
- p. **Clarification or Request for information (RFI)** is a request from the Contractor seeking an interpretation or clarification by the Designer relative to the contract documents. The RFI, which shall be labeled (RFI), shall clearly and concisely set forth the issue or item requiring clarification or interpretation and why the response is needed. The RFI must set forth the Contractor's interpretation or understanding of the contract documents requirements in question, along with reasons for such an understanding.
- q. **Approval** means written or imprinted acknowledgement that materials, equipment or methods of construction are acceptable for use in the work.
- r. **Inspection** shall mean examination or observation of work completed or in progress to determine its compliance with contract documents.
- s. **"Equal to" or "approved equal"** shall mean materials, products, equipment, assemblies, or installation methods considered equal by the bidder in all characteristics (physical, functional, and aesthetic) to those specified in the contract documents. Acceptance of equal is subject to approval of Designer and owner.
- t. **"Substitution" or "substitute"** shall mean materials, products, equipment, assemblies, or installation methods deviating in at least one characteristic (physical, functional, or aesthetic) from those specified, but which in the opinion of the bidder would improve competition and/or enhance the finished installation. Acceptance of substitution is subject to the approval of the Designer and owner.

- u. **Provide** shall mean furnish and install complete in place, new, clean, operational, and ready for use.
- v. **Indicated and shown** shall mean provide as detailed, or called for, and reasonably implied in the contract documents.
- w. **Special inspector** is one who inspects materials, installation, fabrication, erection or placement of components and connections requiring special expertise to ensure compliance with the approved construction documents and referenced standards.
- x. **Commissioning** is a quality assurance process that verifies and documents that building components and systems operate in accordance to the owner's project requirements and the project design documents.
- y. **Designer Final Inspection** is the inspection performed by the design team to determine the completeness of the project in accordance with approved plans and specifications. This inspection occurs prior to SCO final inspection.
- z. **SCO Final Inspection** is the inspection performed by the State Construction Office to determine the completeness of the project in accordance with NC Building Codes and approved plans and specifications.
- aa. **Beneficial Occupancy** is requested by the owner and is occupancy or partial occupancy of the building after all life safety items have been completed as determined by the State Construction Office. Life safety items include but not limited to fire alarm, sprinkler, egress and exit lighting, fire rated walls, egress paths and security.
- bb. Final Acceptance is the date in which the State Construction Office accepts the construction as totally complete. This includes the SCO Final Inspection and certification by the designer that all punch lists are completed.

ARTICLE 2 - INTENT AND EXECUTION OF DOCUMENTS

- a. The drawings and specifications are complementary, one to the other, and that which is shown on the drawings or called for in the specifications shall be as binding as if it were both called for and shown. The intent of the drawings and specifications is to establish the scope of all labor, materials, transportation, equipment, and any and all other things necessary to provide a bid for a complete job. In case of discrepancy or disagreement in the contract documents, the order of precedence shall be: Form of Contract, specifications, large-scale detail drawings, small-scale drawings.
- b. The wording of the specifications shall be interpreted in accordance with common usage of the language except that words having a commonly used technical or trade meaning shall be so interpreted in preference to other meanings.
- c. The contractor shall execute each copy of the proposal, contract, performance bond and payment bond as follows:
 - 1. If the documents are executed by a sole owner, that fact shall be evidenced by the word "Owner" appearing after the name of the person executing them.
 - 2. If the documents are executed by a partnership, that fact shall be evidenced by the word "Co-Partner" appearing after the name of the partner executing them.

3. If the documents are executed on the part of a corporation, they shall be executed by either the president or the vice president and attested by the secretary or assistant secretary in either case, and the title of the office of such persons shall appear after their signatures. The seal of the corporation shall be impressed on each signature page of the documents.
4. If the documents are made by a joint venture, they shall be executed by each member of the joint venture in the above form for sole owner, partnership or corporation, whichever form is applicable to each particular member.
5. All signatures shall be properly witnessed.
6. If the contractor's license is held by a person other than an owner, partner or officer of a firm, then the licensee shall also sign and be a party to the contract. The title "Licensee" shall appear under his/her signature.
7. The bonds shall be executed by an attorney-in-fact. There shall be attached to each copy of the bond a certified copy of power of attorney properly executed and dated.
8. Each copy of the bonds shall be countersigned by an authorized individual agent of the bonding company licensed to do business in North Carolina. The title "Licensed Resident Agent" shall appear after the signature.
9. The seal of the bonding company shall be impressed on each signature page of the bonds.
10. The contractor's signature on the performance bond and the payment bond shall correspond with that on the contract. The date of performance and payment bond shall not be prior to the date of the contract.

ARTICLE 3 - CLARIFICATIONS AND DETAIL DRAWINGS

- a. In such cases where the nature of the work requires clarification by the designer, such clarification shall be furnished by the designer with reasonable promptness by means of written instructions or detail drawings, or both. Clarifications and drawings shall be consistent with the intent of contract documents, and shall become a part thereof.
- b. The contractor(s) and the designer shall prepare, if deemed necessary, a schedule fixing dates upon which foreseeable clarifications will be required. The schedule will be subject to addition or change in accordance with progress of the work. The designer shall furnish drawings or clarifications in accordance with that schedule. The contractor shall not proceed with the work without such detail drawings and/or written clarifications.

ARTICLE 4 - COPIES OF DRAWINGS AND SPECIFICATIONS

The designer or Owner shall furnish free of charge to the contractors electronic copies of plans and specifications. If requested by the contractor, paper copies of plans and specifications shall be furnished free of charge as follows:

- a. General contractor - Up to twelve (12) sets of general contractor drawings and specifications, up to six (6) sets of which shall include drawings and specifications of all other contracts, plus a clean set of black line prints on white paper of all appropriate drawings, upon which the contractor shall clearly and legibly record all work-in-place that is at variance with the contract documents.

- b. Each other contractor - Up to six (6) sets of the appropriate drawings and specifications, up to three (3) sets of which shall include drawings and specifications of all other contracts, plus a clean set of black line prints on white paper of all appropriate drawings, upon which the contractor shall clearly and legibly record all work-in-place that is at variance with the contract documents.
- c. Additional sets shall be furnished at cost, including mailing, to the contractor upon request by the contractor. This cost shall be stated in the bidding documents.
- d. For the purposes of a single-prime contract, the contractor shall receive up to 30 sets of drawings and specifications, plus a clean set of black line prints on white paper of all appropriate drawings, upon which the contractor shall clearly and legibly record all work-in-place that is at variance with the contract documents.

ARTICLE 5 - SHOP DRAWINGS, SUBMITTALS, SAMPLES, DATA

- a. Within 15 consecutive calendar days after the notice to proceed, each prime contractor shall submit a schedule for submission of all shop drawings, product data, samples, and similar submittals through the Project Expediter to the Designer. This schedule shall indicate the items, relevant specification sections, other related submittal, data, and the date when these items will be furnished to the designer.
- b. The Contractor(s) shall review, approve and submit to the Designer all Shop Drawings, Coordination Drawings, Product Data, Samples, Color Charts, and similar submittal data required or reasonably implied by the Contract Documents. Required Submittals shall bear the Contractor's stamp of approval, any exceptions to the Contract Documents shall be noted on the submittals, and copies of all submittals shall be of sufficient quantity for the Designer to retain up to three (3) copies of each submittal for his own use plus additional copies as may be required by the Contractor. Submittals shall be presented to the Designer in accordance with the schedule submitted in paragraph (a). so as to cause no delay in the activities of the Owner or of separate Contractors.
- c. The Designer shall review required submittals promptly, noting desired corrections if any, and retaining three (3) copies (1 for the Designer, 1 for the owner and 1 for SCO) for his use. The remaining copies of each submittal shall be returned to the Contractor not later than twenty (20) days from the date of receipt by the Designer, for the Contractor's use or for corrections and resubmittal as noted by the Designer. When resubmittals are required, the submittal procedure shall be the same as for the original submittals.
- d. Approval of shop drawings/submittals by the Designer shall not be construed as relieving the Contractor from responsibility for compliance with the design or terms of the contract documents nor from responsibility of errors of any sort in the shop drawings, unless such lack of compliance or errors first have been called in writing to the attention of the Designer by the Contractor.

ARTICLE 6 - WORKING DRAWINGS AND SPECIFICATIONS AT THE JOB SITE

- a. The contractor shall maintain, in readable condition at his job office, one complete set of working drawings and specifications for his work including all shop drawings. Such drawings and specifications shall be available for use by the designer, his authorized representative, owner or State Construction Office.

- b. The contractor shall maintain at the job office, a day-to-day record of work-in-place that is at variance with the contract documents. Such variations shall be fully noted on project drawings by the contractor and submitted to the designer upon project completion and no later than 30 days after final acceptance of the project.
- c. The contractor shall maintain at the job office a record of all required tests that have been performed, clearly indicating the scope of work inspected and the date of approval or rejection.

ARTICLE 7 - OWNERSHIP OF DRAWINGS AND SPECIFICATIONS

All drawings and specifications are instruments of service and remain the property of the owner. The use of these instruments on work other than this contract without permission of the owner is prohibited. All copies of drawings and specifications other than contract copies shall be returned to the owner upon request after completion of the work.

ARTICLE 8 - MATERIALS, EQUIPMENT, EMPLOYEES

- a. The contractor shall, unless otherwise specified, supply and pay for all labor, transportation, materials, tools, apparatus, lights, power, heat, sanitary facilities, water, scaffolding and incidentals necessary for the completion of his work, and shall install, maintain and remove all equipment of the construction, other utensils or things, and be responsible for the safe, proper and lawful construction, maintenance and use of same, and shall construct in the best and most workmanlike manner, a complete job and everything incidental thereto, as shown on the plans, stated in the specifications, or reasonably implied therefrom, all in accordance with the contract documents.
- b. All materials shall be new and of quality specified, except where reclaimed material is authorized herein and approved for use. Workmanship shall at all times be of a grade accepted as the best practice of the particular trade involved, and as stipulated in written standards of recognized organizations or institutes of the respective trades except as exceeded or qualified by the specifications.
- c. Upon notice, the contractor shall furnish evidence as to quality of materials.
- d. Products are generally specified by ASTM or other reference standard and/or by manufacturer's name and model number or trade name. When specified only by reference standard, the Contractor may select any product meeting this standard, by any manufacturer. When several products or manufacturers are specified as being equally acceptable, the Contractor has the option of using any product and manufacturer combination listed. However, the contractor shall be aware that the cited examples are used only to denote the quality standard of product desired and that they do not restrict bidders to a specific brand, make, manufacturer or specific name; that they are used only to set forth and convey to bidders the general style, type, character and quality of product desired; and that equivalent products will be acceptable. Request for substitution of materials, items, or equipment shall be submitted to the designer for approval or disapproval; such approval or disapproval shall be made by the designer prior to the opening of bids. Alternate materials may be requested after the award if it can clearly be demonstrated that it is an added benefit to the owner and the designer and owner approves.
- e. The designer is the judge of equality for proposed substitution of products, materials or equipment.

- g. If at any time during the construction and completion of the work covered by these contract documents, the language, conduct, or attire of any workman of the various crafts be adjudged a nuisance to the owner or designer, or if any workman be considered detrimental to the work, the contractor shall order such parties removed immediately from grounds.

ARTICLE 9 - ROYALTIES, LICENSES AND PATENTS

It is the intention of the contract documents that the work covered herein will not constitute in any way infringement of any patent whatsoever unless the fact of such patent is clearly evidenced herein. The contractor shall protect and save harmless the owner against suit on account of alleged or actual infringement. The contractor shall pay all royalties and/or license fees required on account of patented articles or processes, whether the patent rights are evidenced hereinafter.

ARTICLE 10 - PERMITS, INSPECTIONS, FEES, REGULATIONS

- a. The contractor shall give all notices and comply with all laws, ordinances, codes, rules and regulations bearing on the conduct of the work under this contract. If the contractor observes that the drawings and specifications are at variance therewith, he shall promptly notify the designer in writing. See Instructions to Bidders, Paragraph 3, Bulletins and Addenda. Any necessary changes required after contract award shall be made by change order in accordance with Article 19. If the contractor performs any work knowing it to be contrary to such laws, ordinances, codes, rules and regulations, and without such notice to the designer, he shall bear all cost arising therefrom. Additional requirements implemented after bidding will be subject to equitable negotiations.
- b. All work under this contract shall conform to the North Carolina State Building Code and other State, local and national codes as are applicable. The cost of all required inspections and permits shall be the responsibility of the contractor and included within the bid proposal. All water taps, meter barrels, vaults and impact fees shall be paid by the contractor unless otherwise noted.
- d. Projects constructed by the State of North Carolina or by any agency or institution of the State are not subject to inspection by any county or municipal authorities and are not subject to county or municipal building codes. The contractor shall, however, cooperate with the county or municipal authorities by obtaining building permits. Permits shall be obtained at no cost.
- e. Projects involving local funding (community colleges) are subject also to county and municipal building codes and inspection by local authorities. The contractor shall pay the cost of these permits and inspections.

ARTICLE 11 - PROTECTION OF WORK, PROPERTY AND THE PUBLIC

- a. The contractors shall be jointly responsible for the entire site and the building or construction of the same and provide all the necessary protections, as required by the owner or designer, and by laws or ordinances governing such conditions. They shall be responsible for any damage to the owner's property, or of that of others on the job, by them, their personnel, or their subcontractors, and shall make good such damages. They shall be responsible for and pay for any damages caused to the owner. All contractors shall have access to the project at all times.
- b. The contractor shall provide cover and protect all portions of the structure when the work is not in progress, provide and set all temporary roofs, covers for doorways, sash and windows, and all other materials necessary to protect all the work on the building, whether set by him, or any of the subcontractors. Any work damaged through the lack of proper protection or from any other cause, shall be repaired or replaced without extra cost to the owner.
- c. No fires of any kind will be allowed inside or around the operations during the course of construction without special permission from the designer and owner.
- d. The contractor shall protect all trees and shrubs designated to remain in the vicinity of the operations by building substantial boxes around same. He shall barricade all walks, roads, etc., as directed by the designer to keep the public away from the construction. All trenches, excavations or other hazards in the vicinity of the work shall be well barricaded and properly lighted at night.
- e. The contractor shall provide all necessary safety measures for the protection of all persons on the job, including the requirements of the A.G.C. *Accident Prevention Manual in Construction*, as amended, and shall fully comply with all state laws or regulations and North Carolina State Building Code requirements to prevent accident or injury to persons on or about the location of the work. He shall clearly mark or post signs warning of hazards existing, and shall barricade excavations, elevator shafts, stairwells and similar hazards. He shall protect against damage or injury resulting from falling materials and he shall maintain all protective devices and signs throughout the progress of the work.
- f. The contractor shall adhere to the rules, regulations and interpretations of the North Carolina Department of Labor relating to Occupational Safety and Health Standards for the Construction Industry (Title 29, Code of Federal Regulations, Part 1926, published in Volume 39, Number 122, Part II, June 24, 1974, *Federal Register*), and revisions thereto as adopted by General Statutes of North Carolina 95-126 through 155.
- g. The contractor shall designate a responsible person of his organization as safety officer/inspector to inspect the project site for unsafe health and safety hazards, to report these hazards to the contractor for correction, and whose duties also include accident prevention on the project, and to provide other safety and health measures on the project site as required by the terms and conditions of the contract. The name of the safety inspector shall be made known to the designer and owner at the time of the preconstruction conference and in all cases prior to any work starting on the project.
- h. In the event of emergency affecting the safety of life, the protection of work, or the safety of adjoining properties, the contractor is hereby authorized to act at his own discretion, without further authorization from anyone, to prevent such threatened injury or damage.

Any compensation claimed by the contractor on account of such action shall be determined as provided for under Article 19(b).

- i. Any and all costs associated with correcting damage caused to adjacent properties of the construction site or staging area shall be borne by the contractor. These costs shall include but not be limited to flooding, mud, sand, stone, debris, and discharging of waste products.

ARTICLE 12 - SEDIMENTATION POLLUTION CONTROL ACT OF 1973

- a. Any land-disturbing activity performed by the contractor(s) in connection with the project shall comply with all erosion control measures set forth in the contract documents and any additional measures which may be required in order to ensure that the project is in full compliance with the Sedimentation Pollution Control Act of 1973, as implemented by Title 15, North Carolina Administrative Code, Chapter 4, Sedimentation Control, Subchapters 4A, 4B and 4C, as amended (15 N.C.A.C. 4A, 4B and 4C).
- b. Upon receipt of notice that a land-disturbing activity is in violation of said act, the contractor(s) shall be responsible for ensuring that all steps or actions necessary to bring the project in compliance with said act are promptly taken.
- c. The contractor(s) shall be responsible for defending any legal actions instituted pursuant to N.C.G.S. 113A-64 against any party or persons described in this article.
- d. To the fullest extent permitted by law, the contractor(s) shall indemnify and hold harmless the owner, the designer and the agents, consultants and employees of the owner and designer, from and against all claims, damages, civil penalties, losses and expenses, including, but not limited to, attorneys' fees, arising out of or resulting from the performance of work or failure of performance of work, provided that any such claim, damage, civil penalty, loss or expense is attributable to a violation of the Sedimentation Pollution Control Act. Such obligation shall not be construed to negate, abridge or otherwise reduced any other right or obligation of indemnity which would otherwise exist as to any party or persons described in this article.

ARTICLE 13 - INSPECTION OF THE WORK

- a. It is a condition of this contract that the work shall be subject to inspection during normal working hours and during any time work is in preparation and progress by the designer, designated official representatives of the owner, State Construction Office and those persons required by state law to test special work for official approval. The contractor shall therefore provide safe access to the work at all times for such inspections.
- b. All instructions to the contractor will be made only by or through the designer or his designated project representative. Observations made by official representatives of the owner shall be conveyed to the designer for review and coordination prior to issuance to the contractor.
- c. All work shall be inspected by designer, special inspector and/or State Construction Office prior to being covered by the contractor. Contractor shall give a minimum two weeks notice unless otherwise agreed to by all parties. If inspection fails, after the first reinspection all costs associated with additional reinspections shall be borne by the contractor.

- d. Where special inspection or testing is required by virtue of any state laws, instructions of the designer, specifications or codes, the contractor shall give adequate notice to the designer of the time set for such inspection or test, if the inspection or test will be conducted by a party other than the designer. Such special tests or inspections will be made in the presence of the designer, or his authorized representative, and it shall be the contractor's responsibility to serve ample notice of such tests.
- e. All laboratory tests shall be paid by the owner unless provided otherwise in the contract documents except the general contractor shall pay for laboratory tests to establish design mix for concrete, and for additional tests to prove compliance with contract documents where materials have tested deficient except when the testing laboratory did not follow the appropriate ASTM testing procedures.
- f. Should any work be covered up or concealed prior to inspection and approval by the designer, special inspector, and/or State Construction Office such work shall be uncovered or exposed for inspection, if so requested by the designer in writing. Inspection of the work will be made upon notice from the contractor. All cost involved in uncovering, repairing, replacing, recovering and restoring to design condition, the work that has been covered or concealed will be paid by the contractor involved.

ARTICLE 14 - CONSTRUCTION SUPERVISION AND SCHEDULE

- a. Throughout the progress of the work, each contractor shall keep at the job site, a competent superintendent and supervisory staff satisfactory to the designer and the owner. The superintendent and supervisory staff shall not be changed without the consent of the designer and owner unless said superintendent ceases to be employed by the contractor or ceases to be competent as determined by the contractor, designer or owner. The superintendent and other staff designated by the contractor in writing shall have authority to act on behalf of the contractor, and instructions, directions or notices given to him shall be as binding as if given to the contractor. However, directions, instructions, and notices shall be confirmed in writing.
- b. The contractor shall examine and study the drawings and specifications and fully understand the project design, and shall provide constant and efficient supervision to the work. Should he discover any discrepancies of any sort in the drawings or specifications, he shall report them to the designer without delay. He will not be held responsible for discrepancies in the drawings and/or specifications, but shall be held responsible to report them should they become known to him.
- c. All contractors shall be required to cooperate and consult with each other during the construction of this project. Prior to installation of work, all contractors shall jointly prepare coordination drawings, showing locations of various ductworks, piping, motors, pumps, and other mechanical or electrical equipment, in relation to the structure, walls and ceilings. These drawings shall be submitted to the designer through the Project Expediter for information only. Each contractor shall lay out and execute his work to cause the least delay to other contractors. Each contractor shall be financially responsible for any damage to other contractor's work and for undue delay caused to other contractors on the project.
- d. The contractor is required to attend job site progress conferences as called by the designer. The contractor shall be represented at these job progress conferences by both home office and project personnel. These representatives shall have authority to act on behalf of the contractor. These meetings shall be open to subcontractors, material

suppliers and any others who can contribute toward maintaining required job progress. It shall be the principal purpose of these meetings, or conferences, to effect coordination, cooperation and assistance in every practical way toward the end of maintaining progress of the project on schedule and to complete the project within the specified contract time. Each contractor shall be prepared to assess progress of the work as required in his particular contract and to recommend remedial measures for correction of progress as may be appropriate. The designer or his authorized representative shall be the coordinator of the conferences and shall preside as chairman. The contractor shall turn over a copy of his daily reports to the Designer and Owner at the job site progress conference. Owner will determine daily report format.

- e. The contractor(s) shall, employ an engineer or a land surveyor licensed in the State of North Carolina to lay out the work and to establish a bench mark in a location where same will not be disturbed and where direct instruments sights may be taken.
- f. The designer shall designate a Project Expediter on projects involving two or more prime contracts. The Project Expediter shall be designated in the Supplementary General Conditions. The Project Expediter shall have at a minimum the following responsibilities.
 - 1. Prepare the project construction schedule and shall allow all prime contractors (multi-prime contract) and subcontractors (single-prime contract) performing general, plumbing, HVAC, and electrical work equal input into the preparation of the initial construction schedule.
 - 2. Maintain a project progress schedule for all contractors.
 - 3. Give adequate notice to all contractors to ensure efficient continuity of all phases of the work.
 - 4. Notify the designer of any changes in the project schedule.
 - 5. Recommend to the owner whether payment to a contractor shall be approved.
- g. It shall be the responsibility of the Project Expediter to cooperate with and obtain from several prime contractors and subcontractors on the job, their respective work activities and integrate these activities into a project construction schedule in form of a detailed bar chart or Critical Path Method (CPM), schedule. Each prime contractor shall provide work activities within fourteen (14) days of request by the Project Expediter. A “work activity”, for scheduling purposes, shall be any component or contractual requirement of the project requiring at least one (1) day, but not more than fourteen (14) days, to complete or fulfill. The project construction schedule shall graphically show all salient features of the work required to construct the project from start to finish and within the allotted time established in the contract. The time (in days) between the contractor’s early completion and contractual completion dates is part of the project total float time; and shall be used as such, unless amended by a change order. On a multi-prime project, each prime contractor shall review the proposed construction schedule and approve same in writing. The Project Expediter shall submit the proposed construction schedule to the designer for comments. The complete Project construction schedule shall be of the type set forth in the Supplementary General Condition or subparagraph (1) or (2) below, as appropriate:

1. For a project with total contracts of \$500,000 or less, a bar chart schedule will satisfy the above requirement. The schedule shall indicate the estimated starting and completion dates for each major element of the work.
2. For a project with total contracts over \$500,000, a Critical Path Method (CPM) schedule shall be utilized to control the planning and scheduling of the Work. The CPM schedule shall be the responsibility of the Project Expediter and shall be paid for by the Project Expediter.

Bar Chart Schedule: Where a bar chart schedule is required, it shall be time-scaled in weekly increments, shall indicate the estimated starting and completion dates for each major element of the work by trade and by area, level, or zone, and shall schedule dates for all salient features, including but not limited to the placing of orders for materials, submission of shop drawings and other Submittals for approval, approval of shop drawings by designers, the manufacture and delivery of material, the testing and the installation of materials, supplies and equipment, and all Work activities to be performed by the Contractor. The Contractor shall allow sufficient time in his schedule for all commissioning, required inspections and completion of final punchlist(s). Each Work activity will be assigned a time estimate by the Contractor. One day shall be the smallest time unit used.

CPM Schedule: Where a CPM schedule is required, it shall be in time-scaled precedence format using the Project Expediter's logic and time estimates. The CPM schedule shall be drawn or plotted with activities grouped or zoned by Work area or subcontract as opposed to a random (or scattered) format. The CPM schedule shall be time-scaled on a weekly basis and shall be drawn or plotted at a level of detail and logic which will schedule all salient features of the work to be performed by the Contractor. The Contractor shall allow sufficient time in his schedule for all commissioning, required inspections and completion of final punchlist(s).. Each Work activity will be assigned a time estimate by the Contractor. One day shall be the smallest time unit used.

The CPM schedule will identify and describe each activity, state the duration of each activity, the calendar dates for the early and late start and the early and late finish of each activity, and clearly highlight all activities on the critical path. "Total float" and "free float" shall be indicated for all activities. Float time shall not be considered for the exclusive use or benefit of either the Owner or the Contractor, but must be allocated in the best interest of completing the Work within the Contract time. Extensions to the Contract time, when granted by Change Order, will be granted only when equitable time adjustment exceeds the Total Float in the activity or path of activities affected by the change. On contracts with a price over \$2,500,000, the CPM schedule shall also show what part of the Contract Price is attributable to each activity on the schedule, the sum of which for all activities shall equal the total Contract Price.

Early Completion of Project: The Contractor may attempt to complete the project prior to the Contract Completion Date. However, such planned early completion shall be for the Contractor's convenience only and shall not create any additional rights of the Contractor or obligations of the Owner under this Contract, nor shall it change the Time

for Completion or the Contract Completion Date. The Contractor shall not be required to pay liquidated damages to the Owner because of its failure to complete by its planned earlier date. Likewise, the Owner shall not pay the Contractor any additional compensation for early completion nor will the Owner owe the Contractor any compensation should the Owner, its officers, employees, or agents cause the Contractor not to complete earlier than the date required by the Contract Documents.

- h. The proposed project construction schedule shall be presented to the designer no later than fifteen (15) days after written notice to proceed. No application for payment will be processed until this schedule is accepted by the designer and owner.
- i. The approved project construction schedule shall be distributed to all contractors and displayed at the job site by the Project Expediter.
- j. The several contractors shall be responsible for their work activities and shall notify the Project Expediter of any necessary changes or adjustments to their work. The Project Expediter shall maintain the project construction schedule, making biweekly adjustments, updates, corrections, etc., that are necessary to finish the project within the Contract time, keeping all contractors and the designer fully informed. Copy of a bar chart schedule annotated to show the current progress shall be submitted by the Contractor(s) to the designer, along with monthly request for payment. For project requiring CPM schedule, the Contractor shall submit a biweekly report of the status of all activities. The bar chart schedule or status report shall show the actual Work completed to date in comparison with the original Work scheduled for all activities. If any activities of the work of several contractors are behind schedule, the contractor must indicate in writing, what measures will be taken to bring each such activity back on schedule and to ensure that the Contract Completion Date is not exceeded. A plan of action and recovery schedule shall be developed and submitted to the designer by the Project Expediter, when (1) the contractor's report indicates delays, that are in the opinion of the designer or the owner, of sufficient magnitude that the contractor's ability to complete the work by the scheduled completion is brought into question; (2) the updated construction schedule is thirty (30) days behind the planned or baseline schedule and no legitimate time extensions, as determined by the Designer, are in process; and (3) the contractor desires to make changes in the logic (sequencing of work) or the planned duration of future activities of the CPM schedule which, in the opinion of the designer or the owner, are of a major nature. The plan of action, when required shall be submitted to the Owner for review within two (2) business days of the Contractor receiving the Owner's written demand. The recovery schedule, when required, shall be submitted to the Owner within five (5) calendar days of the Contractor's receiving the Owner's written demand. Failure to provide an updated construction schedule or a recovery schedule may be grounds for rejection of payment applications or withholding of funds as set forth in Article 33.
- k. The Project Expediter shall notify each contractor of such events or time frames that are critical to the progress of the job. Such notice shall be timely and reasonable. Should the progress be delayed due to the work of any of the several contractors, it shall be the duty of the Project Expediter to immediately notify the contractor(s) responsible for such delay, the designer, the State Construction Office and other prime contractors. The designer shall determine the contractor(s) who caused the delays and notify the bonding company of the responsible contractor(s) of the delays; and shall make a recommendation to the owner regarding further action.
- l. Designation as Project Expediter entails an additional project control responsibility and does not alter in any way the responsibility of the contractor so designated, nor the

responsibility of the other contractors involved in the project. The project expeditor's Superintendent(s) shall be in attendance at the Project site at all times when work is in progress unless conditions are beyond the control of the Contractor or until termination of the Contract in accordance with the Contract Documents. It is understood that such Superintendent shall be acceptable to the Owner and Designer and shall be the one who will be continued in that capacity for the duration of the project unless he ceases to be on the Contractor's payroll or the Owner otherwise agrees. The Superintendent shall not be employed on any other project for or by the Contractor or by any other entity during the course of the Work. If the Superintendent is employed by the Contractor on another project without the Owner's approval, then the Owner may deduct from the Contractor's monthly general condition costs and amount representing the Superintendent's cost and shall deduct that amount for each month thereafter until the Contractor has the Superintendent back on the Owner's Project full-time.

ARTICLE 15 - SEPARATE CONTRACTS AND CONTRACTOR RELATIONSHIPS

- a. Effective from January 1, 2002, Chapter 143, Article 8, was amended, to allow public contracts to be delivered by the following delivery methods: single-prime, dual (single-prime and separate-prime), construction manager at risk, and alternative contracting method as approved by the State Building Commission. The owner reserves the right to prepare separate specifications, receive separate bids, and award separate contracts for such other major items of work as may be in the best interest of the State. For the purposes of a single prime contract, refer to Article 1 – Definitions.
- b. All contractors shall cooperate with each other in the execution of their work, and shall plan their work in such manner as to avoid conflicting schedules or delay of the work. See Article 14, Construction Supervision.
- c. If any part of contractor's work depends upon the work of another contractor, defects which may affect that work shall be reported to the designer in order that prompt inspection may be made and the defects corrected. Commencement of work by a contractor where such condition exists will constitute acceptance of the other contractor's work as being satisfactory in all respects to receive the work commenced, except as to defects which may later develop. The designer shall be the judge as to the quality of work and shall settle all disputes on the matter between contractors.
- d. Any mechanical or electrical work such as sleeves, inserts, chases, openings, penetrations, etc., which is located in the work of the general contractor shall be built in by the general contractor. The respective mechanical and electrical contractors shall set all sleeves, inserts and other devices that are to be incorporated into the structure in cooperation and under the supervision of the general contractor. The responsibility for the exact location of such items shall be that of the mechanical and/or electrical contractor.
- e. The designer and the owner shall have access to the work whenever it is in preparation and progress and during normal working hours. The contractor shall provide facilities for such access so the designer may perform his functions under the contract documents.
- f. Should a contractor cause damage to the work or property of another contractor, he shall be directly responsible, and upon notice, shall promptly settle the claim or otherwise resolve the dispute.

ARTICLE 16 - SUBCONTRACTS AND SUBCONTRACTORS

- a. Within thirty (30) days after award of the contract, the contractor shall submit to the designer, owner and to the State Construction Office a list giving the names and addresses of subcontractors and equipment and material suppliers he proposes to use, together with the scope of their respective parts of the work. Should any subcontractor be disapproved by the designer or owner, the designer or owner shall submit his reasons for disapproval in writing to the State Construction Office for its consideration with a copy to the contractor. If the State Construction Office concurs with the designer's or owner's recommendation, the contractor shall submit a substitute for approval. The designer and owner shall act promptly in the approval of subcontractors, and when approval of the list is given, no changes of subcontractors will be permitted except for cause or reason considered justifiable by the designer or owner.
- b. The designer will furnish to any subcontractor, upon request, evidence regarding amounts of money paid to the contractor on account of the subcontractor's work.
- c. The contractor is and remains fully responsible for his own acts or omissions as well as those of any subcontractor or of any employee of either. The contractor agrees that no contractual relationship exists between the subcontractor and the owner in regard to the contract, and that the subcontractor acts on this work as an agent or employee of the contractor.
- d. The owner reserves the right to limit the amount of portions of work to be subcontracted as hereinafter specified.

ARTICLE 17 - CONTRACTOR AND SUBCONTRACTOR RELATIONSHIPS

The contractor agrees that the terms of these contract documents shall apply equally to each subcontractor as to the contractor, and the contractor agrees to take such action as may be necessary to bind each subcontractor to these terms. The contractor further agrees to conform to the Code of Ethical Conduct as adopted by the Associated General Contractors of America, Inc., with respect to contractor-subcontractor relationships, and that payments to subcontractors shall be made in accordance with the provisions of G.S. 143-134.1 titled Interest on final payments due to prime contractors: payments to subcontractors.

- a. On all public construction contracts which are let by a board or governing body of the state government or any political subdivision thereof, except contracts let by the Department of Transportation pursuant to G.S. 136-28.1, the balance due prime contractors shall be paid in full within 45 days after respective prime contracts of the project have been accepted by the owner, certified by the architect, engineer or designer to be completed in accordance with terms of the plans and specifications, or occupied by the owner and used for the purpose for which the project was constructed, whichever occurs first. Provided, however, that whenever the architect or consulting engineer in charge of the project determines that delay in completion of the project in accordance with terms of the plans and specifications is the fault of the contractor, the project may be occupied and used for the purposes for which it was constructed without payment of any interest on amounts withheld past the 45 day limit. No payment shall be delayed because of the failure of another prime contractor on such project to complete his contract. Should final payment to any prime contractor beyond the date such contracts have been certified to be completed by the designer or architect, accepted by the owner, or occupied by the owner and used for the purposes for which the project was constructed, be delayed by more than 45 days, said prime contractor shall be paid interest, beginning on the 46th day, at the rate of one percent (1%) per month or fraction thereof unless a lower rate is

agreed upon on such unpaid balance as may be due. In addition to the above final payment provisions, periodic payments due a prime contractor during construction shall be paid in accordance with the payment provisions of the contract documents or said prime contractor shall be paid interest on any such unpaid amount at the rate stipulated above for delayed final payments. Such interest shall begin on the date the payment is due and continue until the date on which payment is made. Such due date may be established by the terms of the contract. Funds for payment of such interest on state-owned projects shall be obtained from the current budget of the owning department, institution or agency. Where a conditional acceptance of a contract exists, and where the owner is retaining a reasonable sum pending correction of such conditions, interest on such reasonable sum shall not apply.

- b. Within seven days of receipt by the prime contractor of each periodic or final payment, the prime contractor shall pay the subcontractor based on work completed or service provided under the subcontract. Should any periodic or final payment to the subcontractor be delayed by more than seven days after receipt of periodic or final payment by the prime contractor, the prime contractor shall pay the subcontractor interest, beginning on the eighth day, at the rate of one percent (1%) per month or fraction thereof on such unpaid balance as may be due.
- c. The percentage of retainage on payments made by the prime contractor to the subcontractor shall not exceed the percentage of retainage on payments made by the owner to the prime contractor. Any percentage of retainage on payments made by the prime contractor to the subcontractor that exceeds the percentage of retainage on payments made by the owner to the prime contractor shall be subject to interest to be paid by the prime contractor to the subcontractor at the rate of one percent (1%) per month or fraction thereof.
- d. Nothing in this section shall prevent the prime contractor at the time of application and certification to the owner from withholding application and certification to the owner for payment to the subcontractor for unsatisfactory job progress; defective construction not remedied; disputed work; third-party claims filed or reasonable evidence that claim will be filed; failure of subcontractor to make timely payments for labor, equipment and materials; damage to prime contractor or another subcontractor; reasonable evidence that subcontract cannot be completed for the unpaid balance of the subcontract sum; or a reasonable amount for retainage not to exceed the initial percentage retained by owner.

ARTICLE 18 - DESIGNER'S STATUS

- a. The designer shall provide general administration of the performance of construction contracts, including liaison and necessary inspection of the work to ensure compliance with plans and specifications. He is the agent of the owner only for the purpose of constructing this work and to the extent stipulated in the contract documents. He has authority to direct work to be performed, to stop work, to order work removed, or to order corrections of faulty work, where any such action by the designer may be necessary to assure successful completion of the work.
- b. The designer is the impartial interpreter of the contract documents, and, as such, he shall exercise his powers under the contract to enforce faithful performance by both the owner and the contractor, taking sides with neither.
- c. Should the designer cease to be employed on the work for any reason whatsoever, then the owner shall employ a competent replacement who shall assume the status of the former designer.

- d. The designer and his consultants will make inspections of the project. He will inspect the progress, the quality and the quantity of the work.
- e. The designer and the owner shall have access to the work whenever it is in preparation and progress during normal working hours. The contractor shall provide facilities for such access so the designer and owner may perform their functions under the contract documents.
- f. Based on the designer's inspections and evaluations of the project, the designer shall issue interpretations, directives and decisions as may be necessary to administer the project. His decisions relating to artistic effect and technical matters shall be final, provided such decisions are within the limitations of the contract.

ARTICLE 19 - CHANGES IN THE WORK

- a. The owner may have changes made in the work covered by the contract. These changes will not invalidate and will not relieve or release the contractor from any guarantee given by him pertinent to the contract provisions. These changes will not affect the validity of the guarantee bond and will not relieve the surety or sureties of said bond. All extra work shall be executed under conditions of the original contract.
- b. Except in an emergency endangering life or property, no change shall be made by the contractor except upon receipt of approved change order or written field order from the designer, countersigned by the owner and the state construction office authorizing such change. No claim for adjustments of the contract price shall be valid unless this procedure is followed.

A field order, transmitted by fax, electronically, or hand delivered, may be used where the change involved impacts the critical path of the work. A formal change order shall be issued as expeditiously as possible.

In the event of emergency endangering life or property, the contractor may be directed to proceed on a time and material basis whereupon the contractor shall proceed and keep accurately on such form as specified by the designer or owner, a correct account of costs together with all proper invoices, payrolls and supporting data. Upon completion of the work the change order will be prepared as outlined under either Method "c(1)" or Method "c(2)" or both.

- c. In determining the values of changes, either additive or deductive, contractors are restricted to the use of the following methods:
 - 1. Where the extra work involved is covered by unit prices quoted in the proposal, or subsequently agreed to by the Contractor, Designer, Owner and State Construction Office the value of the change shall be computed by application of unit prices based on quantities, estimated or actual as agreed of the items involved, except in such cases where a quantity exceeds the estimated quantity allowance in the contract by one hundred percent (100%) or more. In such cases, either party may elect to proceed under subparagraph c2 herein. If neither party elects to proceed under c2, then unit prices shall apply.
 - 2. The contracting parties shall negotiate and agree upon the equitable value of the change prior to issuance of the change order, and the change order shall stipulate the corresponding lump sum adjustment to the contract price.

- d. Under Paragraph "b" and Methods "c(2)" above, the allowances for overhead and profit combined shall be as follows: all contractors (the single contracting entity (prime), his subcontractors(1st tier subs), or their sub-subcontractors (2nd tier subs, 3rd tier subs, etc)) shall be allowed a maximum of 10% on work they each self-perform; the prime contractor shall be allowed a maximum of 5% on contracted work of his 1st tier sub; 1st tier, 2nd tier, 3rd tier, etc contractors shall be allowed a maximum of 2.5% on the contracted work of their subs. ; Under Method "c(1)", no additional allowances shall be made for overhead and profit. In the case of deductible change orders, under Method "c(2)" and Paragraph (b) above, the contractor shall include no less than five percent (5%) profit, but no allowances for overhead.
- e. The term "net cost" as used herein shall mean the difference between all proper cost additions and deductions. The "cost" as used herein shall be limited to the following:
1. The actual costs of materials and supplies incorporated or consumed as part of the work;
 2. The actual costs of labor expended on the project site; labor expended in coordination, change order negotiation, record document maintenance, shop drawing revision or other tasks necessary to the administration of the project are considered overhead whether they take place in an office or on the project site.
 3. The actual costs of labor burden, limited to the costs of social security (FICA) and Medicare/Medicaid taxes; unemployment insurance costs; health/dental/vision insurance premiums; paid employee leave for holidays, vacation, sick leave, and/or petty leave, not to exceed a total of 30 days per year; retirement contributions; worker's compensation insurance premiums; and the costs of general liability insurance when premiums are computed based on payroll amounts; the total of which shall not exceed thirty percent (30%) of the actual costs of labor;
 4. The actual costs of rental for tools, excluding hand tools; equipment; machinery; and temporary facilities required for the work;
 5. The actual costs of premiums for bonds, insurance, permit fees, and sales or use taxes related to the work.

Overtime and extra pay for holidays and weekends may be a cost item only to the extent approved by the owner.

- f. Should concealed conditions be encountered in the performance of the work below grade, or should concealed or unknown conditions in an existing structure be at variance with the conditions indicated by the contract documents, the contract sum and time for completion may be equitably adjusted by change order upon claim by either party made within thirty (30) days after the condition has been identified. The cost of such change shall be arrived at by one of the foregoing methods. All change orders shall be supported by a unit cost breakdown showing method of arriving at net cost as defined above.
- g. In all change orders, the procedure will be for the designer to request proposals for the change order work in writing. The contractor will provide such proposal and supporting data in suitable format. The designer shall verify correctness. Delay in the processing of the change order due to lack of proper submittal by the contractor of all required supporting data shall not constitute grounds for a time extension or basis of a claim. Within fourteen (14) days after receipt of the contractor's accepted proposal including all supporting documentation required by the designer, the designer shall prepare the change order and forward to the contractor for his signature or otherwise respond, in writing, to

the contractor's proposal. Within seven (7) days after receipt of the change order executed by the contractor, the designer shall, certify the change order by his signature, and forward the change order and all supporting data to the owner for the owner's signature. The owner shall execute the change order and forward to the State Construction Office for final approval, within seven (7) days of receipt. The State Construction Office shall act on the change order within seven (7) days. In case of emergency or extenuating circumstances, approval of changes may be obtained verbally by telephone or field orders approved by all parties, then shall be substantiated in writing as outlined under normal procedure.

- h. At the time of signing a change order, the contractor shall be required to certify as follows:

"I certify that my bonding company will be notified forthwith that my contract has been changed by the amount of this change order, and that a copy of the approved change order will be mailed upon receipt by me to my surety."

- i. A change order, when issued, shall be full compensation, or credit, for the work included, omitted or substituted. It shall show on its face the adjustment in time for completion of the project as a result of the change in the work.
- j. If, during the progress of the work, the owner requests a change order and the contractor's terms are unacceptable, the owner, with the approval of the State Construction Office, may require the contractor to perform such work on a time and material basis whereupon the contractor shall proceed and keep accurately on such form as specified by the Designer or owner, a correct account of cost together with all proper invoices, payrolls and supporting data. Upon completion of the work a change order will be prepared with allowances for overhead and profit per paragraph d. above and "net cost" and "cost" per paragraph e. above. Without prejudice, nothing in this paragraph shall preclude the owner from performing or to have performed that portion of the work requested in the change order.

ARTICLE 20 - CLAIMS FOR EXTRA COST

- a. Should the contractor consider that as a result of instructions given by the designer, he is entitled to extra cost above that stated in the contract, he shall give written notice thereof to the designer within seven (7) days without delay. The written notice shall clearly state that a claim for extra cost is being made and shall provide a detailed justification for the extra cost. The contractor shall not proceed with the work affected until further advised, except in emergency involving the safety of life or property, which condition is covered in Article 19(b) and Article 11(h). No claims for extra compensation shall be considered unless the claim is so made. The designer shall render a written decision within seven (7) days of receipt of claim.
- b. The contractor shall not act on instructions received by him from persons other than the designer, and any claims for extra compensation or extension of time on account of such instruction will not be honored. The designer shall not be responsible for misunderstandings claimed by the contractor of verbal instructions which have not been confirmed in writing, and in no case shall instructions be interpreted as permitting a departure from the contract documents unless such instruction is confirmed in writing and supported by a properly authorized change order.
- c. Should a claim for extra compensation that complies with the requirements of (a) above by the contractor and is denied by the designer or owner, and cannot be resolved by a

representative of the State Construction Office, the contractor may request a mediation in connection with GS 143-128(f1) in the dispute resolution rules adopted by the State Building Commission (1 N.C.A.C. 30H .0101 through .1001). If the contractor is unable to resolve its claim as a result of mediation, the contractor may pursue the claim in accordance with the provisions of G.S. 143-135.3, or G.S. 143-135.6 where Community Colleges are the owner, and the following:

1. A contractor who has not completed a contract with a board for construction or repair work and who has not received the amount he claims is due under the contract may submit a verified written claim to the director of the State Construction Office of the Department of Administration for the amount the contractor claims is due. The director may deny, allow or compromise the claim, in whole or in part. A claim under this subsection is not a contested case under Chapter 150B of the General Statutes.
2. (a) A contractor who has completed a contract with a board for construction or repair work and who has not received the amount he claims is due under the contract may submit a verified written claim to the director of the State Construction Office of the Department of Administration for the amount the contractor claims is due. The claim shall be submitted within sixty (60) days after the contractor receives a final statement of the board's disposition of his claim and shall state the factual basis for the claim.
 - (b) The director shall investigate a submitted claim within ninety (90) days of receiving the claim, or within any longer time period upon which the director and the contractor agree. The contractor may appear before the director, either in person or through counsel, to present facts and arguments in support of his claim. The director may allow, deny or compromise the claim, in whole or in part. The director shall give the contractor a written statement of the director's decision on the contractor's claim.
 - (c) A contractor who is dissatisfied with the director's decision on a claim submitted under this subsection may commence a contested case on the claim under Chapter 150B of the General Statutes. The contested case shall be commenced within sixty (60) days of receiving the director's written statement of the decision.
 - (d) As to any portion of a claim that is denied by the director, the contractor may, in lieu of the procedures set forth in the preceding subsection of this section, within six (6) months of receipt of the director's final decision, institute a civil action for the sum he claims to be entitled to under the contract by filing a verified complaint and the issuance of a summons in the Superior Court of Wake County or in the superior court of any county where the work under the contract was performed. The procedure shall be the same as in all civil actions except that all issues shall be tried by the judge, without a jury.

ARTICLE 21 - MINOR CHANGES IN THE WORK

The designer will have the authority to order minor changes in the work not involving an adjustment in the contract sum or time for completion, and not inconsistent with the intent of the contract documents. Such changes shall be effected by written order, copied to the State Construction Office, and shall be binding on the owner and the contractor.

ARTICLE 22 - UNCORRECTED FAULTY WORK

Should the correction of faulty or damaged work be considered inadvisable or inexpedient by the owner and the designer, the owner shall be reimbursed by the contractor. A change order will be issued to reflect a reduction in the contract sum.

ARTICLE 23 - TIME OF COMPLETION, DELAYS, EXTENSION OF TIME

- a. The time of completion is stated in the Supplementary General Conditions and in the Form of Construction Contract. The Project Expediter, upon notice of award of contract, shall prepare a construction schedule to complete the project within the time of completion as required by Article 14.
- b. The contractors shall commence work to be performed under this agreement on a date to be specified in a written Notice to Proceed from the designer and shall fully complete all work hereunder within the time of completion stated. Time is of the essence and the contractor acknowledges the Owner will likely suffer financial damage for failure to complete the work within the time of completion. For each day in excess of the above number of days, the contractor(s) shall pay the owner the sum stated as liquidated damages reasonably estimated in advance to cover the losses to be incurred by the owner by reason of failure of said contractor(s) to complete the work within the time specified, such time being in the essence of this contract and a material consideration thereof.
- c. In the event of multiple prime contractors, the designer shall be the judge as to the division of responsibility between the contractor(s), based on the construction schedule, weekly reports and job records, and shall apportion the amount of liquidated damages to be paid by each of them, according to delay caused by any or all of them.
- d. If the contractor is delayed at any time in the progress of his work solely by any act or negligence of the owner, the designer, or by any employee of either; by any separate contractor employed by the owner; by changes ordered in the work; by labor disputes at the project site; by abnormal weather conditions not reasonably anticipated for the locality where the work is performed; by unavoidable casualties; by any causes beyond the contractor's control; or by any other causes which the designer and owner determine may justify the delay, then the contract time may be extended by change order only for the time which the designer and owner may determine is reasonable.

Time extensions will not be granted for rain, wind, snow or other natural phenomena of normal intensity for the locality where work is performed. For purpose of determining extent of delay attributable to unusual weather phenomena, a determination shall be made by comparing the weather for the contract period involved with the average of the preceding five (5) year climatic range during the same time interval based on the National Oceanic and Atmospheric Administration National Weather Service statistics for the locality where work is performed and on daily weather logs kept on the job site by the contractor reflecting the effect of the weather on progress of the work and initialed by the designer's representative. No weather delays shall be considered after the building is dried in unless work claimed to be delayed is on the critical path of the baseline schedule or approved updated schedule. Time extensions for weather delays, acts of God, labor disputes, fire, delays in transportation, unavoidable casualties or other delays which are beyond the control of the Owner do not entitle the Contractor to compensable damages for delays. Any contractor claim for compensable damages for delays is limited to delays caused solely by the owner or its agents. Contractor caused delays shall be accounted for before owner or designer caused delays in the case of concurrent delays.

- e. Request for extension of time shall be made in writing to the designer, copies to the owner and SCO, within twenty (20) days following cause of delay. In case of continuing cause for delay, the Contractor shall notify the Designer to the designer, copies to the owner and SCO, of the delay within 20 days of the beginning of the delay and only one claim is necessary.
- f. The contractor shall notify his surety in writing of extension of time granted.
- g. No claim for time extension shall be allowed on account of failure of the designer to furnish drawings or instructions until twenty (20) days after demand for such drawings and/or instructions. See Article 5c. Demand must be in written form clearly stating the potential for delay unless the drawings or instructions are provided. Any delay granted will begin after the twenty (20) day demand period is concluded.

ARTICLE 24 - PARTIAL UTILIZATION/BENEFICIAL OCCUPANCY

- a. The owner may desire to occupy or utilize all or a portion of the project prior to the completion of the project.
- b. Should the owner request a utilization of a building or portion thereof, the designer shall perform a designer final inspection of area after being notified by the contractor that the area is ready for such. After the contractor has completed designer final inspection punch list and the designer has verified, then the designer shall schedule a beneficial occupancy inspection at a time and date acceptable to the owner, contractor(s) and State Construction Office. If beneficial occupancy is granted by the State Construction Office, in such areas the following will be established:
 - 1. The beginning of guarantees and warranties period for the equipment necessary to support. in the area.
 - 2. The owner assumes all responsibilities for utility costs for entire building.
 - 2. Contractor will obtain consent of surety.
 - 3. Contractor will obtain endorsement from insurance company permitting beneficial occupancy.
- c. The owner shall have the right to exclude the contractor from any part of the project which the designer has so certified to be substantially complete, but the owner will allow the contractor reasonable access to complete or correct work to bring it into compliance with the contract.
- d. Occupancy by the owner under this article will in no way relieve the contractor from his contractual requirement to complete the project within the specified time. The contractor will not be relieved of liquidated damages because of beneficial occupancy. The designer may prorate liquidated damages based on the percentage of project occupied.

ARTICLE 25 - FINAL INSPECTION, ACCEPTANCE, AND PROJECT CLOSEOUT

- a. Upon notification from the contractor(s) that the project is complete and ready for inspection, the designer shall make a Designer final inspection to verify that the project is complete and ready for SCO final inspection. Prior to SCO final inspection, the contractor(s) shall complete all items requiring corrective measures noted at the Designer

final inspection. The designer shall schedule a SCO final inspection at a time and date acceptable to the owner, contractor(s) and State Construction Office.

- b. At the SCO final inspection, the designer and his consultants shall, if job conditions warrant, record a list of items that are found to be incomplete or not in accordance with the contract documents. At the conclusion of the SCO final inspection, the designer and State Construction Office representative shall make one of the following determinations:
 - 1. That the project is completed and accepted.
 - 2. That the project will be accepted subject to the correction of the list of discrepancies (punch list). All punch list items must be completed within thirty (30) days of SCO final inspection or the owner may invoke Article 28, Owner's Right to Do Work.
 - 4. That the project is not complete and another date for a SCO final inspection will be established.
- c. Within fourteen (14) days of final acceptance per Paragraph b1 or within fourteen (14) days after completion of punch list per Paragraph b2 above, the designer shall certify the work and issue applicable certificate(s) of compliance.
- d. Any discrepancies listed or discovered after the date of SCO final inspection and acceptance under Paragraphs b1 or b2 above shall be handled in accordance with Article 42, Guarantee.
- f. The final acceptance date will establish the following:
 - 1. The beginning of guarantees and warranties period.
 - 2. The date on which the contractor's insurance coverage for public liability, property damage and builder's risk may be terminated.
 - 3. That no liquidated damages (if applicable) shall be assessed after this date.
 - 4. The termination date of utility cost to the contractor.
- g. Prior to issuance of final acceptance date, the contractor shall have his authorized representatives visit the project and give full instructions to the designated personnel regarding operating, maintenance, care, and adjustment of all equipment and special construction elements. In addition, the contractor shall provide to the owner a complete instructional video (media format acceptable to the owner) on the operation, maintenance, care and adjustment of all equipment and special construction elements.**

ARTICLE 26 - CORRECTION OF WORK BEFORE FINAL PAYMENT

- a. Any work, materials, fabricated items or other parts of the work which have been condemned or declared not in accordance with the contract by the designer shall be promptly removed from the work site by the contractor, and shall be immediately replaced by new work in accordance with the contract at no additional cost to the owner. Work or property of other contractors or the owner, damaged or destroyed by virtue of such faulty work, shall be made good at the expense of the contractor whose work is faulty.

- b. Correction of condemned work described above shall commence within twenty-four (24) hours after receipt of notice from the designer, and shall make satisfactory progress, as determined by the designer, until completed.
- c. Should the contractor fail to proceed with the required corrections, then the owner may complete the work in accordance with the provisions of Article 28.

ARTICLE 27 - CORRECTION OF WORK AFTER FINAL PAYMENT

See Article 35, Performance Bond and Payment Bond, and Article 42, Guarantee. Neither the final certificate, final payment, occupancy of the premises by the owner, nor any provision of the contract, nor any other act or instrument of the owner, nor the designer, shall relieve the contractor from responsibility for negligence, or faulty material or workmanship, or failure to comply with the drawings and specifications. Contractor shall correct or make good any defects due thereto and repair any damage resulting there from, which may appear during the guarantee period following final acceptance of the work except as stated otherwise under Article 42, Guarantee. The owner will report any defects as they may appear to the contractor and establish a time limit for completion of corrections by the contractor. The owner will be the judge as to the responsibility for correction of defects.

ARTICLE 28 - OWNER'S RIGHT TO DO WORK

If, during the progress of the work or during the period of guarantee, the contractor fails to prosecute the work properly or to perform any provision of the contract, the owner, after seven (7) days' written notice sent by certified mail, return receipt requested, to the contractor from the designer, may perform or have performed that portion of the work. The cost of the work may be deducted from any amounts due or to become due to the contractor, such action and cost of same having been first approved by the designer. Should the cost of such action of the owner exceed the amount due or to become due the contractor, then the contractor or his surety, or both, shall be liable for and shall pay to the owner the amount of said excess.

ARTICLE 29 - ANNULMENT OF CONTRACT

If the contractor fails to begin the work under the contract within the time specified, or the progress of the work is not maintained on schedule, or the work is not completed within the time above specified, or fails to perform the work with sufficient workmen and equipment or with sufficient materials to ensure the prompt completion of said work, or shall perform the work unsuitably or shall discontinue the prosecution of the work, or if the contractor shall become insolvent or be declared bankrupt or commit any act of bankruptcy or insolvency, or allow any final judgment to stand against him unsatisfied for a period of forty-eight (48) hours, or shall make an assignment for the benefit of creditors, or for any other cause whatsoever shall not carry on the work in an acceptable manner, the owner may give notice in writing, sent by certified mail, return receipt requested, to the contractor and his surety of such delay, neglect or default, specifying the same, and if the contractor within a period of seven (7) days after such notice shall not proceed in accordance therewith, then the owner shall, declare this contract in default, and, thereupon, the surety shall promptly take over the work and complete the performance of this contract in the manner and within the time frame specified. In the event the surety shall fail to take over the work to be done under this contract within seven (7) days after being so notified and notify the owner in writing, sent by certified mail, return receipt requested, that he is taking the same over and stating that he will diligently pursue and complete the same, the owner shall have full power and authority, without violating the contract, to take the prosecution of the work out of the hands of said contractor, to appropriate or use any or all contract materials and equipment on the grounds as may be suitable and acceptable and may enter into an agreement, either by public letting or negotiation, for the completion of said contract according to the terms and provisions thereof

or use such other methods as in his opinion shall be required for the completion of said contract in an acceptable manner. All costs and charges incurred by the owner, together with the costs of completing the work under contract, shall be deducted from any monies due or which may become due said contractor and surety. In case the expense so incurred by the owner shall be less than the sum which would have been payable under the contract, if it had been completed by said contractor, then the said contractor and surety shall be entitled to receive the difference, but in case such expense shall exceed the sum which would have been payable under the contract, then the contractor and the surety shall be liable and shall pay to the owner the amount of said excess.

ARTICLE 30 - CONTRACTOR'S RIGHT TO STOP WORK OR TERMINATE THE CONTRACT

- a. Should the work be stopped by order of a court having jurisdiction, or by order of any other public authority for a period of three months, due to cause beyond the fault or control of the contractor, or if the owner should fail or refuse to make payment on account of a certificate issued by the designer within forty-five (45) days after receipt of same, then the contractor, after fifteen (15) days' written notice sent by certified mail, return receipt requested, to the owner and the designer, may suspend operations on the work or terminate the contract.
- b. The owner shall be liable to the contractor for the cost of all materials delivered and work performed on this contract plus 10 percent overhead and profit and shall make such payment. The designer shall be the judge as to the correctness of such payment.

ARTICLE 31 - REQUEST FOR PAYMENT

- a. Not later than the fifth day of the month, the contractor shall submit to the designer a request for payment for work done during the previous month. The request shall be in the form agreed upon between the contractor and the designer, but shall show substantially the value of work done and materials delivered to the site during the period since the last payment, and shall sum up the financial status of the contract with the following information:
 1. Total of contract including change orders.
 2. Value of work completed to date.
 3. Less five percent (5%) retainage, provided however, that after fifty percent (50%) of the contractor's work has been satisfactorily completed on schedule, with approval of the owner and the State Construction Office and written consent of the surety, further requirements for retainage will be waived only so long as work continues to be completed satisfactorily and on schedule.
 4. Less previous payments.
 5. Current amount due.
- b. The contractor, upon request of the designer, shall substantiate the request with invoices of vouchers or payrolls or other evidence.
- c. Prior to submitting the first request, the contractor shall prepare for the designer a schedule showing a breakdown of the contract price into values of the various parts of the work, so arranged as to facilitate payments to subcontractors in accordance with Article 17, Contractor and Subcontractor Relationships. The contractor(s) shall list the

value of each subcontractor and supplier, identifying each minority business subcontractor and supplier as listed in Affidavit C, if applicable.

- d. When payment is made on account of stored materials and equipment, such materials must be stored on the owner's property, and the requests for payments shall be accompanied by invoices or bills of sale or other evidence to establish the owner's title to such materials and equipment. Such payments will be made only for materials that have been customized or fabricated specifically for this project. Raw materials or commodity products including but not limited to piping, conduit, CMU, metal studs and gypsum board may not be submitted. Responsibility for such stored materials and equipment shall remain with the contractor regardless of ownership title. Such stored materials and equipment shall not be removed from the owner's property. Should the space for storage on-site be limited, the contractor, at his option, shall be permitted to store such materials and/or equipment in a suitable space off-site. Should the contractor desire to include any such materials or equipment in his application for payment, they must be stored in the name of the owner in an independent, licensed, bonded warehouse approved by the designer, owner and the State Construction Office and located as close to the site as possible. The warehouse selected must be approved by the contractor's bonding and insurance companies; the material to be paid for shall be assigned to the owner and shall be inspected by the designer. Upon approval by the designer, owner and SCO of the storage facilities and materials and equipment, payment therefore will be certified. Responsibility for such stored materials and equipment shall remain with the contractor. Such stored materials and equipment shall not be moved except for transportation to the project site. Under certain conditions, the designer may approve storage of materials at the point of manufacture, which conditions shall be approved by the designer, the owner and the State Construction Office prior to approval for the storage and shall include an agreement by the storing party which unconditionally gives the State absolute right to possession of the materials at anytime. Bond, security and insurance protection shall continue to be the responsibility of the contractor(s).
- e. In the event of beneficial occupancy, retainage of funds due the contractor(s) may be reduced with the approval of the State Construction Office to an equitable amount to cover the list of items to be completed or corrected. Retainage may not be reduced to less than two and one-half (2 1/2) times the estimated value of the work to be completed or corrected. Reduction of retainage must be with the consent and approval of the contractor's bonding company.

ARTICLE 32 - CERTIFICATES OF PAYMENT AND FINAL PAYMENT

- a. Within five (5) days from receipt of request for payment from the contractor, the designer shall issue and forward to the owner a certificate for payment. This certificate shall indicate the amount requested or as approved by the designer. If the certificate is not approved by the designer, he shall state in writing to the contractor and the owner his reasons for withholding payment.
- b. No certificate issued or payment made shall constitute an acceptance of the work or any part thereof. The making and acceptance of final payment shall constitute a waiver of all claims by the owner except:
 1. Claims arising from unsettled liens or claims against the contractor.
 2. Faulty work or materials appearing after final payment.
 3. Failure of the contractor to perform the work in accordance with drawings and specifications, such failure appearing after payment.

4. As conditioned in the performance bond and payment bond.
- c. The making and acceptance of final payment shall constitute a waiver of all claims by the contractor except those claims previously made and remaining unsettled (Article 20(c)).
- d. Prior to submitting request for final payment to the designer for approval, the contractor shall fully comply with all requirements specified in the “project closeout” section of the specifications. These requirements include but not limited to the following:
 1. Submittal of Product and Operating Manuals, Warranties and Bonds, Guarantees, Maintenance Agreements, As-Built Drawings, Certificates of Inspection or Approval from agencies having jurisdiction. (The designer must approve the Manuals prior to delivery to the owner).
 2. Transfer of Required attic stock material and all keys in an organized manner.
 3. Record of Owner’s training.
 4. Resolution of any final inspection discrepancies.
 5. Granting access to Contractor’s records, if Owner’s internal auditors have made a request for such access pursuant to Article 52.
- e. The contractor shall forward to the designer, the final application for payment along with the following documents:
 1. List of minority business subcontractors and material suppliers showing breakdown of contract amounts and total actual payments to subs and material suppliers.
 2. Affidavit of Release of Liens.
 3. Affidavit of contractors of payment to material suppliers and subcontractors. (See Article 36).
 4. Consent of Surety to Final Payment.
 5. Certificates of state agencies required by state law.
- f. The designer will not authorize final payment until the work under contract has been certified by designer, certificates of compliance issued, and the contractor has complied with the closeout requirements. The designer shall forward the contractor’s final application for payment to the owner along with respective certificate(s) of compliance required by law.

ARTICLE 33 - PAYMENTS WITHHELD

- a. The designer with the approval of the State Construction Office may withhold payment for the following reasons:
 1. Faulty work not corrected.

2. The unpaid balance on the contract is insufficient to complete the work in the judgment of the designer.
 3. To provide for sufficient contract balance to cover liquidated damages that will be assessed.
- b. The secretary of the Department of Administration may authorize the withholding of payment for the following reasons:
 1. Claims filed against the contractor or evidence that a claim will be filed.
 2. Evidence that subcontractors have not been paid.
 - c. The Owner may withhold all or a portion of Contractor's general conditions costs set forth in the approved schedule of values, if Contractor has failed to comply with: (1) a request to access its records by Owner's internal auditors pursuant to Article 52; (2) a request for a plan of action and/or recovery schedule under Article 14.j or provide The Owner; (3) a request to provide an electronic copies of Contractor's baseline schedule, updates with all logic used to create the schedules in the original format of the scheduling software; and (4) Contractor's failure to have its Superintendent on the Project full-time; (
 - d. When grounds for withholding payments have been removed, payment will be released. Delay of payment due the contractor without cause will make owner liable for payment of interest to the contractor in accordance with G.S. 143-134.1. As provided in G.S.143-134.1(e) the owner shall not be liable for interest on payments withheld by the owner for unsatisfactory job progress, defective construction not remedied, disputed work, or third-party claims filed against the owner or reasonable evidence that a third-party claim will be filed.

ARTICLE 34 - MINIMUM INSURANCE REQUIREMENTS

The work under this contract shall not commence until the contractor has obtained all required insurance and verifying certificates of insurance have been approved in writing by the owner. These certificates shall document that coverages afforded under the policies will not be cancelled, reduced in amount or coverages eliminated until at least thirty (30) days after mailing written notice, by certified mail, return receipt requested, to the insured and the owner of such alteration or cancellation. If endorsements are needed to comply with the notification or other requirements of this article copies of the endorsements shall be submitted with the certificates.

a. **Worker's Compensation and Employer's Liability**

The contractor shall provide and maintain, until final acceptance, workmen's compensation insurance, as required by law, as well as employer's liability coverage with minimum limits of \$100,000.

b. **Public Liability and Property Damage**

The contractor shall provide and maintain, until final acceptance, comprehensive general liability insurance, including coverage for premises operations, independent contractors, completed operations, products and contractual exposures, as shall protect such contractors from claims arising out of any bodily injury, including accidental death, as well as from claims for property damages which may arise from operations under this contract, whether such operations be by the contractor or by any subcontractor, or by

anyone directly or indirectly employed by either of them and the minimum limits of such insurance shall be as follows:

Bodily Injury: \$500,000 per occurrence
Property Damage: \$100,000 per occurrence / \$300,000 aggregate

In lieu of limits listed above, a \$500,000 combined single limit shall satisfy both conditions.

Such coverage for completed operations must be maintained for at least two (2) years following final acceptance of the work performed under the contract.

c. Property Insurance (Builder's Risk/Installation Floater)

The contractor shall purchase and maintain property insurance until final acceptance, upon the entire work at the site to the full insurable value thereof. This insurance shall include the interests of the owner, the contractor, the subcontractors and sub-subcontractors in the work and shall insure against the perils of fire, wind, rain, flood, extended coverage, and vandalism and malicious mischief. If the owner is damaged by failure of the contractor to purchase or maintain such insurance, then the contractor shall bear all reasonable costs properly attributable thereto; the contractor shall effect and maintain similar property insurance on portions of the work stored off the site when request for payment per articles so includes such portions.

d. Deductible

Any deductible, if applicable to loss covered by insurance provided, is to be borne by the contractor.

e. Other Insurance

The contractor shall obtain such additional insurance as may be required by the owner or by the General Statutes of North Carolina including motor vehicle insurance, in amounts not less than the statutory limits.

f. Proof of Carriage

The contractor shall furnish the owner with satisfactory proof of carriage of the insurance required before written approval is granted by the owner.

ARTICLE 35 - PERFORMANCE BOND AND PAYMENT BOND

- a. Each contractor shall furnish a performance bond and payment bond executed by a surety company authorized to do business in North Carolina. The bonds shall be in the full contract amount. Bonds shall be executed in the form bound with these specifications.
- b. All bonds shall be countersigned by an authorized agent of the bonding company who is licensed to do business in North Carolina.

ARTICLE 36 - CONTRACTOR'S AFFIDAVIT

The final payment of retained amount due the contractor on account of the contract shall not become due until the contractor has furnished to the owner through the designer an affidavit signed, sworn and notarized to the effect that all payments for materials, services or subcontracted work in connection with his contract have been satisfied, and that no claims or

liens exist against the contractor in connection with this contract. In the event that the contractor cannot obtain similar affidavits from subcontractors to protect the contractor and the owner from possible liens or claims against the subcontractor, the contractor shall state in his affidavit that no claims or liens exist against any subcontractor to the best of his (the contractor's) knowledge, and if any appear afterward, the contractor shall save the owner harmless.

ARTICLE 37 - ASSIGNMENTS

The contractor shall not assign any portion of this contract nor subcontract in its entirety. Except as may be required under terms of the performance bond or payment bond, no funds or sums of money due or become due the contractor under the contract may be assigned.

ARTICLE 38 - USE OF PREMISES

- a. The contractor(s) shall confine his apparatus, the storage of materials and the operations of his workmen to limits indicated by law, ordinances, permits or directions of the designer and owner and shall not exceed those established limits in his operations.
- b. The contractor(s) shall not load or permit any part of the structure to be loaded with a weight that will endanger its safety.
- c. The contractor(s) shall enforce the designer's and owner's instructions regarding signs, advertisements, fires and smoking.
- d. No firearms, any type of alcoholic beverages, or drugs (other than those prescribed by a physician) will be permitted at the job site.

ARTICLE 39 - CUTTING, PATCHING AND DIGGING

- a. The contractor shall do all cutting, fitting or patching of his work that may be required to make its several parts come together properly and fit it to receive or be received by work of other contractors shown upon or reasonably implied by the drawings and specifications for the completed structure, as the designer may direct.
- b. Any cost brought about by defective or ill-timed work shall be borne by the party responsible therefor.
- c. No contractor shall endanger any work of another contractor by cutting, digging or other means. No contractor shall cut or alter the work of any other contractor without the consent of the designer and the affected contractor(s).

ARTICLE 40 - UTILITIES, STRUCTURES, SIGNS

- a. The contractor shall provide necessary and adequate facilities for water, electricity, gas, oil, sewer and other utility services which maybe necessary and required for completion of the project including all utilities required for testing, cleaning, balancing, and sterilization of designated plumbing, mechanical and electrical systems. Any permanent meters installed shall be listed in the contractor's name until work has a final acceptance. The contractor will be solely responsible for all utility costs prior to final acceptance. Contractor shall contact all affected utility companies prior to bid to determine their requirements to provide temporary and permanent service and include all costs associated with providing those services in their bid. Coordination of the work of the utility companies during construction is the sole responsibility of the contractor.

- b. Meters shall be relisted in the owner's name on the day following final acceptance of the Project Expediter's work, and the owner shall pay for services used after that date.
- c. The owner shall be reimbursed for all metered utility charges after the meter is relisted in the owner's name and prior to completion and acceptance of the work of **all** contractors. Reimbursement shall be made by the contractor whose work has not been completed and accepted. If the work of two or more contractors has not been completed and accepted, reimbursement to the owner shall be paid by the contractors involved on the basis of assessments by the designer.
- d. Prior to the operation of permanent systems, the Project Expediter will provide temporary power, lighting, water, and heat to maintain space temperature above freezing, as required for construction operations.
- e. All contractors shall have the permanent building systems in sufficient readiness for furnishing temporary climatic control at the time a building is enclosed and secured. The HVAC systems shall maintain climatic control throughout the enclosed portion of the building sufficient to allow completion of the interior finishes of the building. A building shall be considered enclosed and secured when windows, doorways (exterior, mechanical, and electrical equipment rooms), and hardware are installed; and other openings have protection which will provide reasonable climatic control. The appropriate time to start the mechanical systems and climatic condition shall be jointly determined by the contractor(s), the designer and owner. Use of the equipment in this manner shall be subject to the approval of the Designer and owner and shall in no way affect the warranty requirements of the contractor(s).
- f. The electrical contractor shall have the building's permanent power wiring distribution system in sufficient readiness to provide power as required by the HVAC contractor for temporary climatic control.
- g. The electrical contractor shall have the building's permanent lighting system ready at the time the general contractor begins interior painting and shall provide adequate lighting in those areas where interior painting and finishing is being performed.
- h. Each prime contractor shall be responsible for his permanently fixed service facilities and systems in use during progress of the work. The following procedures shall be strictly adhered to:
 - 1. Prior to final acceptance of work by the State Construction Office, each contractor shall remove and replace any parts of the permanent building systems damaged through use during construction.
 - 2. Temporary filters as recommended by the equipment manufacturer in order to keep the equipment and ductwork clean and free of dust and debris shall be installed in each of the heating and air conditioning units and at each return grille during construction. New filters shall be installed in each unit prior to the owner's acceptance of the work.
 - 3. Extra effort shall be maintained to keep the building and the site adjacent to the building clean and under no circumstances shall air systems be operated if finishing and site work operations are creating dust in excess of what would be considered normal if the building were occupied.
 - 4. It shall be understood that any warranty on equipment presented to the owner shall extend from the day of final acceptance by the owner. The cost of warranting the

equipment during operation in the finishing stages of construction shall be borne by the contractor whose system is utilized.

5. The electrical contractor shall have all lamps in proper working condition at the time of final project acceptance.
 - i. The Project Expediter shall provide, if required and where directed, a shed for toilet facilities and shall furnish and install in this shed all water closets required for a complete and adequate sanitary arrangement. These facilities will be available to other contractors on the job and shall be kept in a neat and sanitary condition at all times. Chemical toilets are acceptable.
 - j. The Project Expediter shall, if required by the Supplementary General Conditions and where directed, erect a temporary field office, complete with lights, telephone, heat and air conditioning. A portion of this office shall be partitioned off, of sufficient size, for the use of a resident inspector, should the designer so direct.
 - k. On multi-story construction projects, the Project Expediter shall provide temporary elevators, lifts, or other special equipment for the general use of all contractors. The cost for such elevators, lifts or other special equipment and the operation thereof shall be included in the Project Expediter's bid.
 - l. The Project Expediter will erect one sign on the project if required. The sign shall be of sound construction, and shall be neatly lettered with black letters on white background. The sign shall bear the name of the project, and the names of prime contractors on the project, and the name of the designer and consultants. Directional signs may be erected on the owner's property subject to approval of the owner with respect to size, style and location of such directional signs. Such signs may bear the name of the contractor and a directional symbol. No other signs will be permitted except by permission of the owner.

ARTICLE 41 - CLEANING UP

- a. The contractors shall keep the building and surrounding area reasonably free from rubbish at all times, and shall remove debris from the site on a timely basis or when directed to do so by the designer or Project Expediter. The Project Expediter shall provide an on site refuse container(s) for the use of all contractors. Each contractor shall remove their rubbish and debris from the building on a daily basis. The Project Expediter shall broom clean the building as required to minimize dust and dirt accumulation.
- b. The Project Expediter shall provide and maintain suitable all-weather access to the building.
- c. Before final inspection and acceptance of the building, each contractor shall clean his portion of the work, including glass, hardware, fixtures, masonry, tile and marble (using no acid), clean and wax all floors as specified, and completely prepare the building for use by the owner, with no cleaning required by the owner.

ARTICLE 42 - GUARANTEE

- a. The contractor shall unconditionally guarantee materials and workmanship against patent defects arising from faulty materials, faulty workmanship or negligence for a period of twelve (12) months following the date of final acceptance of the work or beneficial occupancy and shall replace such defective materials or workmanship without cost to the owner.

- b. Where items of equipment or material carry a manufacturer's warranty for any period in excess of twelve (12) months, then the manufacturer's warranty shall apply for that particular piece of equipment or material. The contractor shall replace such defective equipment or materials, without cost to the owner, within the manufacturer's warranty period.
- c. Additionally, the owner may bring an action for latent defects caused by the negligence of the contractor which is hidden or not readily apparent to the owner at the time of beneficial occupancy or final acceptance, whichever occurred first, in accordance with applicable law.
- d. Guarantees for roof, equipment, materials, and supplies shall be stipulated in the specifications sections governing such roof, equipment, materials, or supplies.

ARTICLE 43 - CODES AND STANDARDS

Wherever reference is given to codes, standard specifications or other data published by regulating agencies including, but not limited to, national electrical codes, North Carolina state building codes, federal specifications, ASTM specifications, various institute specifications, etc., it shall be understood that such reference is to the latest edition including addenda published prior to the date of the contract documents.

ARTICLE 44 - INDEMNIFICATION

To the fullest extent permitted by law, the contractor shall indemnify and hold harmless the owner, the designer and the agents, consultants and employees of the owner and designer, from and against all claims, damages, losses and expenses, including, but not limited to, attorneys' fees, arising out of or resulting from the performance or failure of performance of the work, provided that any such claim, damage, loss or expense (1) is attributable to bodily injury, sickness, disease or death, or to injury to or destruction of tangible property (other than the work itself) including the loss of use resulting there from, and (2) is caused in whole or in part by any negligent act or omission of the contractor, the contractor's subcontractor, or the agents of either the contractor or the contractor's subcontractor. Such obligation shall not be construed to negate, abridge or otherwise reduce any other right or obligation of indemnity which would otherwise exist as to any party or person described in this article.

ARTICLE 45 - TAXES

- a. Federal excise taxes do not apply to materials entering into state work (Internal Revenue Code, Section 3442(3)).
- b. Federal transportation taxes do not apply to materials entering into state work (Internal Revenue Code, Section 3475(b) as amended).
- c. North Carolina sales tax and use tax, as required by law, do apply to materials entering into state work and such costs shall be included in the bid proposal and contract sum.
- d. Local option sales and use taxes, as required by law, do apply to materials entering into state work as applicable and such costs shall be included in the bid proposal and contract sum.
- e. **Accounting Procedures for Refund of County Sales & Use Tax**

Amount of county sales and use tax paid per contractor's statements:

Contractors performing contracts for state agencies shall give the state agency for whose project the property was purchased a signed statement containing the information listed in G.S. 105-164.14(e).

The Department of Revenue has agreed that in lieu of obtaining copies of sales receipts from contractors, an agency may obtain a certified statement as of April 1, 1991 from the contractor setting forth the date, the type of property and the cost of the property purchased from each vendor, the county in which the vendor made the sale and the amount of local sales and use taxes paid thereon. If the property was purchased out-of-state, the county in which the property was delivered should be listed. The contractor should also be notified that the certified statement may be subject to audit.

In the event the contractors make several purchases from the same vendor, such certified statement must indicate the invoice numbers, the inclusive dates of the invoices, the total amount of the invoices, the counties, and the county sales and use taxes paid thereon.

Name of taxing county: The position of a sale is the retailer's place of business located within a taxing county where the vendor becomes contractually obligated to make the sale. Therefore, it is important that the county tax be reported for the county of sale rather than the county of use.

When property is purchased from out-of-state vendors and the county tax is charged, the county should be identified where delivery is made when reporting the county tax.

Such statement must also include the cost of any tangible personal property withdrawn from the contractor's warehouse stock and the amount of county sales or use tax paid thereon by the contractor.

Similar certified statements by his subcontractors must be obtained by the general contractor and furnished to the claimant.

Contractors are not to include any tax paid on supplies, tools and equipment which they use to perform their contracts and should include only those building materials, supplies, fixtures and equipment which actually become a part of or annexed to the building or structure.

ARTICLE 46 - EQUAL OPPORTUNITY CLAUSE

The non-discrimination clause contained in Section 202 (Federal) Executive Order 11246, as amended by Executive Order 11375, relative to equal employment opportunity for all persons without regard to race, color, religion, sex or national origin, and the implementing rules and regulations prescribed by the secretary of Labor, are incorporated herein.

ARTICLE 47 - EMPLOYMENT OF INDIVIDUALS WITH DISABILITIES

The contractor(s) agree not to discriminate against any employee or applicant for employment because of physical or mental disabilities in regard to any position for which the employee or applicant is qualified. The contractor agrees to take affirmative action to employ, advance in employment and otherwise treat qualified individuals with such disabilities without discrimination based upon their physical or mental disability in all employment practices.

ARTICLE 48 - ASBESTOS-CONTAINING MATERIALS (ACM)

The State of North Carolina has attempted to address all asbestos-containing materials that are to be disturbed in the project. However, there may be other asbestos-containing materials in the work areas that are not to be disturbed and do not create an exposure hazard.

Contractors are reminded of the requirements of instructions under Instructions to Bidders and General Conditions of the Contract, titled Examination of Conditions. Statute 130A, Article 19, amended August 3, 1989, established the Asbestos Hazard Management Program that controls asbestos abatement in North Carolina. The latest edition of *Guideline Criteria for Asbestos Abatement* from the State Construction Office is to be incorporated in all asbestos abatement projects for the Capital Improvement Program.

ARTICLE 49 - MINORITY BUSINESS PARTICIPATION

GS 143-128.2 establishes a ten percent (10%) goal for participation by minority businesses in total value of work for each State building project. The document, *Guidelines for Recruitment and Selection of Minority Businesses for Participation in State Construction Contracts* including Affidavits and Appendix E are hereby incorporated into and made a part of this contract.

ARTICLE 50 – CONTRACTOR EVALUATION

The contractor's overall work performance on the project shall be fairly evaluated in accordance with the State Building Commission policy and procedures, for determining qualifications to bid on future State capital improvement projects. In addition to final evaluation, interim evaluation may be prepared during the progress of project. The document, *Contractor Evaluation Procedures*, is hereby incorporated and made a part of this contract. The owner may request the contractor's comments to evaluate the designer.

ARTICLE 51 – GIFTS

Pursuant to N.C. Gen. Stat. § 133-32, it is unlawful for any vendor or contractor (i.e. architect, bidder, contractor, construction manager, design professional, engineer, subcontractor, supplier, vendor, etc.), to make gifts or to give favors to any State employee. This prohibition covers those vendors and contractors who: (1) have a contract with a governmental agency; or (2) have performed under such a contract within the past year; or (3) anticipate bidding on such a contract in the future. For additional information regarding the specific requirements and exemptions, vendors and contractors are encouraged to review G.S. Sec. 133-32.

During the construction of the Project, the Contractor is prohibited from making gifts to any of the Owner's employees, Owner's project representatives (architect, engineers, construction manager and their employees), employees of the State Construction Office and/or any other State employee that may have any involvement, influence, responsibilities, oversight, management and/or duties that pertain to and/or relate to the contract administration, financial administration and/or disposition of claims arising from and/or relating to the Contract and/or Project.

ARTICLE 52 – AUDITING-ACCESS TO PERSONS AND RECORDS

In accordance with N.C. General Statute 147-64.7, the State Auditor shall have access to Contractor's officers, employees, agents and/or other persons in control of and/or responsible for the Contractor's records that relate to this Contracts for purposes of conducting audits under the referenced statute. The Owner's internal auditors shall also have the right to access and copy the Contractor's records relating to the Contract and Project during the term of the Contract and within two years following the completion of the Project/close-out of the Contract to verify accounts, accuracy, information, calculations and/or data affecting and/or

relating to Contractor's requests for payment, requests for change orders, change orders, claims for extra work, requests for time extensions and related claims for delay/extended general conditions costs, claims for lost productivity, claims for loss efficiency, claims for idle equipment or labor, claims for price/cost escalation, pass-through claims of subcontractors and/or suppliers, and/or any other type of claim for payment or damages from Owner and/or its project representatives.

ARTICLE 53 – NORTH CAROLINA FALSE CLAIMS ACT

The North Carolina False Claims Act ("NCFCA"), N.C. Gen. Stat. § 1-605 through 1-618, applies to this Contract. The Contractor should familiarize itself with the entire NCFCA and should seek the assistance of an attorney if it has any questions regarding the NCFCA and its applicability to any requests, demands and/or claims for payment its submits to the State through the contracting state agency, institution, university or community college.

The purpose of the NCFCA "is to deter persons from knowingly causing or assisting in causing the State to pay claims that are false or fraudulent and to provide remedies in the form of treble damages and civil penalties when money is obtained from the State by reason of a false or fraudulent claim." (Section 1-605(b).) A contractor's liability under the NCFCA may arise from, but is not limited to: requests for payment, invoices, billing, claims for extra work, requests for change orders, requests for time extensions, claims for delay damages/extended general conditions costs, claims for lost productivity, claims for loss efficiency, claims for idle equipment or labor, claims for price/cost escalation, pass-through claims of subcontractors and/or suppliers, documentation used to support any of the foregoing requests or claims, and/or any other request for payment from the State through the contracting state agency, institution, university or community college. The parts of the NCFCA that are most likely to be enforced with respect to this type of contract are as follows:

- A "claim" is "[a]ny request or demand, whether under a contract or otherwise, for money or property and whether or not the State has title to the money or property that (i) is presented to an officer, employee, or agent of the State or (ii) is made to a contractor ... if the money or property is to be spent or used on the State's behalf or to advance a State program or interest and if the State government: (a) provides or has provided any portion of the money or property that is requested or demanded; or (b) will reimburse such contractor ... for any portion of the money or property which is requested or demanded." (Section 1-606(2).)
- "Knowing" and "knowingly." – Whenever a person, with respect to information, does any of the following: (a) Has actual knowledge of the information; (b) Acts in deliberate ignorance of the truth or falsity of the information; and/or (c) Acts in reckless disregard of the truth or falsity of the information. (Section 1-606(4).) Proof of specific intent to defraud is not required. (Section 1-606(4).)
- "Material" means having a natural tendency to influence, or be capable of influencing, the payment or receipt of money or property. (Section 1-606(4).)
- Liability. – "Any person who commits any of the following acts shall be liable to the State for three times the amount of damages that the State sustains because of the act of that person[:]. ... (1) Knowingly presents or causes to be presented a false or fraudulent claim for payment or approval. (2) Knowingly makes, uses, or causes to be made or used, a false record or statement material to a false or fraudulent claim. (3) Conspires to commit a violation of subdivision (1), (2) ..." (Section 1-607(a)(1), (2).)

- The NCFCA shall be interpreted and construed so as to be consistent with the federal False Claims Act, 31 U.S.C. § 3729, et seq., and any subsequent amendments to that act. (Section 1-616(c).)

Finally, the contracting state agency, institution, university or community college may refer any suspected violation of the NCFCA by the Contractor to the Attorney General's Office for investigation. Under Section 1-608(a), the Attorney General is responsible for investigating any violation of NCFCA, and may bring a civil action against the Contractor under the NCFCA. The Attorney General's investigation and any civil action relating thereto are independent and not subject to any dispute resolution provision set forth in this Contract. (See Section 1-608(a).)

ARTICLE 54 – TERMINATION FOR CONVENIENCE

Owner may at any time and for any reason terminate Contractor's services and work at Owner's convenience. Upon receipt of such notice, Contractor shall, unless the notice directs otherwise, immediately discontinue the work and placing of orders for materials, facilities and supplies in connection with the performance of this Agreement.

Upon such termination, Contractor shall be entitled to payment only as follows: (1) the actual cost of the work completed in conformity with this Agreement; plus, (2) such other costs actually incurred by Contractor as are permitted by the prime contract and approved by Owner; (3) plus ten percent (10%) of the cost of the work referred to in subparagraph (1) above for overhead and profit. There shall be deducted from such sums as provided in this subparagraph the amount of any payments made to Contractor prior to the date of the termination of this Agreement. Contractor shall not be entitled to any claim or claim of lien against Owner for any additional compensation or damages in the event of such termination and payment.

SUPPLEMENTARY GENERAL CONDITIONS

GENERAL

The following conditions modify, change, delete from or add to the Instruction to Bidders and General Conditions of the Contract (Form OC-15, Twenty-Fourth Edition dated January 2013). Where any portion of this document is modified, or deleted by these supplements, the unaltered provisions of that portion shall remain in effect.

Wherever “State Construction Office” is referenced, substitute “Town of Carrboro”.

INSTRUCTIONS TO BIDDERS

Add the following to item 7:

- h. Prior to contract award, the Contractor shall provide any breakdowns requested by the Owner, such as breakdown by subcontracts or major components, any certifications (Debarment, etc.) and any documents required to comply with legal and/or administrative requirements.

Add the following to item 11:

Pre-Bid Conference: A pre-bid conference will be held by the Engineers and the Owner on site at the Carrboro Century Center, 100 N. Greensboro, NC 27510 at 2:00 PM March 12, 2024. Any additions and/or alteration to specifications and/or drawings that may be agreed upon during the meeting shall be documented in a written addendum. Any addenda issued will become a part of the contract documents. To be considered responsive and responsible bidders, the prime contractor and first tier subcontractors (general, mechanical and electrical) shall attend either the pre-bid conference or a site visit at a later date scheduled by the Owner, or both. Attendance must be documented by the Engineers or the Owner. Without attending one of these, the contractor’s bid will not be accepted.

An open public meeting will be held in conjunction with the pre-bid conference to identify preferred brand alternates and their performance standards pertinent to this project. In accordance with GS133-3, Section 64. (C) procedures the following preferred brand items are being considered as Alternates by the owner for this project:

- A. Owner Preferred Alternate No. OP-M1: Provide DDC controls by Honeywell Building Technologies, subject to compliance with the requirements of the specifications.

A copy of pertinent sections of the performance standards may be obtained by contacting the designer at the address or phone number noted herein.

Add the following to item 12:

Each contractor shall obtain written approval from the designer for the use of substitute products, materials, or equipment claimed as equal to those specified.

Products are generally specified by ASTM or other reference standard and/or by manufacturer's name and model number or trade name. When several products or manufacturers are specified as being equally acceptable, the Contractor has the option of using any product and manufacturer combination listed. **However, the contractor shall be aware that the cited examples are used only to denote the quality standard of product desired and that they do not restrict bidders to a specified brand, make, manufacturer or specific name; that they are used only to set forth and convey to**

bidders the general style, type, character and quality of product desired; and that equivalent products will be acceptable. Substitution of materials, items or equipment of equal or equivalent design shall be submitted to the architect or engineer for approval or disapproval; SUCH APPROVAL OR DISAPPROVAL SHALL BE MADE BY THE ARCHITECT OR ENGINEER 10 DAYS PRIOR TO THE OPENING OF BIDS.

GENERAL CONDITIONS OF THE CONTRACT

ARTICLE 1 - DEFINITIONS

Delete Article 1b and substitute:

The Owner named in the contract is the Town of Carrboro.

Add the following to Article 1c:

The Designer named in the contract is Sud Associates, P.A.

ARTICLE 8 - MATERIALS, EQUIPMENT, EMPLOYEES

Add the following to paragraph 8g.

- g. Workers making offensive or insulting remarks to employees or visitors shall be immediately removed from the site as directed by the Designer or the Owner's representative. The playing of radios, tape decks or CD's will not be permitted. Workers must wear shirts at all times.

ARTICLE 10 - PERMITS, INSPECTIONS, FEES, REGULATIONS

Add the following section c.

- c. Inspection Certificates – This project is subject to Town of Carrboro Inspections and Permitting. It shall be the responsibility of the Contractor to request and coordinate inspections. Obtain all inspection certificates required by law, ordinances, rules and regulations of the Authorities having jurisdiction. Provide to the Engineer certificates of such inspections, pay all fees, charges, and other expenses in connection therewith, prior to final payment.

Disregard paragraph d.

ARTICLE 14 - CONSTRUCTION SUPERVISION AND SCHEDULE

After the first sentence of Paragraph 14d add:

Once construction begins, the Owner or Designer may schedule weekly job site progress conferences until the work is complete.

Replace Paragraph 14f-1 with the following:

Prepare the project construction schedule and allow all subcontractors (single-prime contract) performing general construction work, HVAC work, plumbing work and electrical work equal input into the preparation of the initial construction schedule.

ARTICLE 16 - SUBCONTRACTS AND SUBCONTRACTORS

Paragraph 16a: Insert the following after the first sentence:

The qualifications of any subcontractor or material supplier listed shall be submitted upon request from the Designer or the Owner.

ARTICLE 19 - CHANGES IN THE WORK

Add the following to Paragraph 19f:

The breakdown shall show labor, material and equipment expense per unit and in total for every component of the work to be included in the proposed change order.

ARTICLE 20 - CLAIMS FOR EXTRA COST

Paragraph 20a: Insert the following after the first sentence:

The contractor shall also provide a copy of the written notice to the Owner.

ARTICLE 23 - TIME OF COMPLETION, DELAYS, EXTENSION OF TIME

Replace Article 23b. with the following:

The contractor shall commence work to be performed under agreement on a date to be specified in a written order from the Designer and shall fully complete all work hereunder, including project closeout, within 350 consecutive calendar days.

Work is expected to occur during normal business hours, with the exception of up to 6 VAV boxes which may require after-hours work for the controls upgrade. The intent is to replace the chiller during the heating season, with chiller startup occurring no later than March 1, 2025.

The contractor is advised that the building will be occupied during portions of the construction period. Any interruption to the building utilities and services shall be minimized.

Night, weekend, and holiday work shall be included in the contractor's bid if the contractor deems it appropriate for meeting the schedule. No additional compensation will be provided if work has to be performed over nights, weekends, and holidays to meet the schedule and was not originally included. The Contractor's schedule shall include a reasonable allowance for interruptions due to inclement weather and unforeseen circumstances. The liquidated damages will not be waived if work is not complete due to these factors.

If the construction work is not completed in the time period allotted, the Contractor shall pay the Owner the amount of Five Hundred Dollars (\$500) per day as liquidated damages reasonably estimated in advance to cover the losses to be incurred by the Owner should the Contractor fail to complete the Work within the time specified.

ARTICLE 32 - CERTIFICATES OF PAYMENT AND FINAL PAYMENT

Add the following to Paragraph 32e.:

6. Operation and Maintenance Manuals.
7. Record Drawings
8. Notarized contractor's affidavit and letter certifying that no hazardous materials were introduced. The contractor's affidavit shall state: "This is to certify that all costs of materials, equipment, labor, and all else entering into the accomplishment of this contract, including payrolls, have been paid in full." The contractor's certification letter shall state: "This is to certify that no hazardous materials, including lead, asbestos, or PCB's were introduced into the building during the course of this project. If it is discovered at a later

date that an asbestos-containing product or hazardous material was used, (name of contractor) will remove it and restore the project to its original working condition at no cost to the Owner.”

ARTICLE 33 - PAYMENTS WITHHELD

Add the following to paragraph a.:

4. Failure to maintain and submit accurate and current progress schedules as specified in Article 14.
5. Failure to maintain and submit accurate and current record drawings as specified in Article 6.

ARTICLE 34 – MINIMUM INSURANCE REQUIREMENTS

Replace paragraph c. with the following:

“The contractor shall purchase and maintain property insurance during the life of this contract, upon the entire work at the site to the full insurable value thereof. This insurance shall include the interests of the owner, the contractor, the subcontractors and sub-subcontractors in the work and shall insure against risks of direct physical loss - (all perils). If the owner is damaged by failure of the contractor to purchase or maintain such insurance, then the contractor shall bear all reasonable costs properly attributable thereto; the contractor shall affect and maintain similar property insurance on portions of the work stored off the site when request for payment per articles so includes such portions.”

ARTICLE 38 - USE OF PREMISES

Delete Paragraph 38a. and include the following:

- a. The Contractors shall confine their apparatus, trucks, cars, storage of materials, trailers and the operations of their workmen to the limits of construction as defined by the construction fence or approved by the Owner. No other area will be provided by the Owner for the Contractor’s use. Keep existing driveways and entrances serving the premises clear and available to the Owner, his employees and visitors at all times. Do not use these areas for parking or storage of materials. Do not unreasonably encumber the site with materials or equipment. Confine stockpiling of materials and location of storage sheds to areas agreeable with the Owner. If additional storage is necessary, obtain and pay for such storage off site. Lock automotive type vehicles, such as passenger cars and trucks and other mechanized or motorized construction equipment, when parked and unattended, so as to prevent unauthorized use. Do not leave such vehicles or equipment unattended with the motor running or the ignition key in place. Contractor Use of the Existing Building: Maintain the existing building in a safe and weather tight condition throughout the construction period. Repair damage caused by construction operations. Take all precautions necessary to protect the building and its occupants during the construction period. Smoking or open fires will not be permitted within the building enclosure or on the premises.

ARTICLE 39 - CUTTING, PATCHING & DIGGING

Add the following Paragraph 39d.:

Comply with provisions of "Underground Damage Prevention Act" enacted by N.C. Legislature (hereinafter referred to as "the act"). The act is effective January 1, 1986. Use care to avoid damaging any underground utilities, especially those in any public right-of-way or private easement owned by a utility company. Note such underground utilities shown on drawings, if any. Those shown do not necessarily represent all that may occur. Each Contractor shall be responsible for the protection of underground and overhead utilities in his work area which are shown on the Drawings

and/or which can be detected by a visual inspection of the job site. Each Contractor is cautioned, however, that there may exist unknown underground utilities neither visible nor shown on the Drawings. Each Contractor shall take all reasonable precautions to detect and preserve the services which these utilities provide. The Contractor shall contact ULOCO prior to digging for assistance in locating underground utility lines.

ARTICLE 40 – UTILITIES, STRUCTURES, SIGNS

Paragraph a:

The Owner will pay for utilities during the construction of this project.

Add the following to paragraph a:

Temporary Utilities - The following items shall be provided by the Owner during construction:

1. Electrical Power: The Contractor shall provide temporary lines necessary for power, with source coordinated with the Owner.
2. Water: The Contractor shall provide all temporary piping to convey water to point of use, with source coordinated with the Owner
3. Existing Mechanical and Electrical Systems: Caution shall be exercised during the installation of work specified herein and as shown on the plans to prevent any damage to existing mechanical or electrical equipment to the building. In the event, such damage occurred due to direct or indirect cause of the new construction, the offending contractor shall be responsible for the repair and/or revenue loss by the Owner.
4. Toilet Facilities: The Contractor shall provide temporary toilet facilities.
5. Use of electrical power, water, and heating and cooling facilities shall be coordinated with the Building Owner prior to start of construction. Any damage or misuse to the existing building services or facilities shall be repaired or cleaned up as soon as noted by the Owner. Failure to take necessary steps to correct a noted problem shall result in the Owner taking care of the problem with the cost being reimbursed by the Contractor.
6. All requirements for utilities, storage, etc. shall be coordinated and approved by the designated project manager for the College.
7. Any shutdown of an existing utility must be approved in writing by the Owner at least 5 days in advance. If necessary to avoid interruption, work shall be done at night, on weekends or during holidays. No extra payment will be made for such work.

ARTICLE 45 – TAXES

Delete paragraphs a through e and substitute the following:

Sales and Use Tax

The Town is NOT exempt from applicable sales or use taxes assessed by North Carolina or other states. However, the North Carolina Department of Revenue does reimburse the Town for the North Carolina sales or use taxes the Town pays for certain construction related goods. Therefore, the Town utilizes the below procedures for such sales tax. The Contractor agrees to follow the procedures set forth below for all sales or use taxes related to the Work and any other work performed pursuant to this contract.

“Eligible Taxes” are defined as North Carolina sales or use taxes paid by the Contractor for buildings, materials, supplies, fixtures and equipment that become a part of or annexed to any building or structure that is owned or leased by the Town and is being erected, altered or repaired by the Town (North Carolina GS 105-164-14(c)).

“Non-Eligible Taxes” are defined as all other sales or use taxes including those paid to states other

than North Carolina, or sales or use taxes paid to North Carolina on purchases or rental of tools, equipment, and disposable supplies, including fuel, used in the Work.

Tax Statements must show separately the portion of Eligible Taxes that are paid to the State of North Carolina and the applicable North Carolina county, identifying the county accordingly.

END OF SUPPLEMENTARY GENERAL CONDITIONS

FORM OF PROPOSAL

Century Center Chiller Replacement and

DDC Controls Upgrade _____

Town of Carrboro _____

Town of Carrboro Project ID #: 20-2023

Contract: _____

Bidder: _____

Date: _____

The undersigned, as bidder, hereby declares that the only person or persons interested in this proposal as principal or principals is or are named herein and that no other person than herein mentioned has any interest in this proposal or in the contract to be entered into; that this proposal is made without connection with any other person, company or parties making a bid or proposal; and that it is in all respects fair and in good faith without collusion or fraud. The bidder further declares that he has examined the site of the work and the contract documents relative thereto and has read all special provisions furnished prior to the opening of bids; that he has satisfied himself relative to the work to be performed. The bidder further declares that he and his subcontractors have fully complied with NCGS 64, Article 2 in regards to E-Verification as required by Section 2. (c) of Session Law 2013-418, codified as N.C. Gen. Stat. § 143-129(j).

The Bidder proposes and agrees if this proposal is accepted to contract with the, Town of Carrboro, in the form of contract specified below, to furnish all necessary materials, equipment, machinery, tools, apparatus, means of transportation and labor necessary to complete the construction of Century Center Chiller Replacement and DDC Controls Upgrade, in full in complete accordance with the plans, specifications and contract documents, to the full and entire satisfaction of the Town of Carrboro, and Sud Associates, P.A. with a definite understanding that no money will be allowed for extra work except as set forth in the General Conditions and the contract documents, for the sum of:

SINGLE PRIME CONTRACT:

Base Bid: _____ Dollars(\$)

General Subcontractor:
_____ Lic _____

Plumbing Subcontractor:
_____ Lic _____

Mechanical Subcontractor:
_____ Lic _____

Electrical Subcontractor:
_____ Lic _____

GS143-128(d) requires all single prime bidders to identify their subcontractors for the above subdivisions of work. A contractor whose bid is accepted shall not substitute any person as subcontractor in the place of the subcontractor listed in the original bid, except (i) if the listed subcontractor's bid is later determined by the contractor to be non-responsible or non-responsive or the listed subcontractor refuses to enter into a contract for the complete performance of the bid work, or (ii) with the approval of the awarding authority for good cause shown by the contractor.

ALTERNATES:

The Bidder proposes to perform the work indicated as alternates for the amounts entered below, which amounts shall be added to or deducted from the Base Bid as indicated in the space below.

(Bidders must enter an amount for each alternate. If acceptance of the alternate will not change the contract amount, enter "No Change". Insert the words "Add" or "Deduct" in the space provided before the amount.)

List of Owner Preferred Alternate:

Add/Deduct

Amount

No. OP-M1 #1: Provide DDC controls by Honeywell Building Technology, subject to compliance with the requirements of the specifications

_____ \$ _____

ALLOWANCES

Allowance No. 1: Contingency Allowance

Allowance for replacing existing devices found to be faulty.

Allowance Amount Base Bid = (\$)30,000.00

UNIT PRICES

Unit prices quoted and accepted shall apply throughout the life of the contract, except as otherwise specifically noted. Unit prices shall be applied, as appropriate, to compute the total value of changes in the base bid quantity of the work all in accordance with the contract documents.

MECHANICAL CONTRACT:

No. A	Provide price for replacing a faulty water control valve (1/2" through 1")	<u>Per Valve</u>	Unit Price (\$)_____
No. B	Provide price for replacing a faulty water control valve (1 - 1/4" through 2")	<u>Per Valve</u>	Unit Price (\$)_____
No. C	Provide price for replacing a faulty control damper	<u>Per sq. ft damper</u>	Unit Price (\$)_____
No. D	Provide price for replacing a faulty valve actuator for 1/2" through 1"	<u>Per valve actuator</u>	Unit Price (\$)_____
No. E	Provide price for replacing a faulty valve actuator for 1-1/4" through 2"	<u>Per valve actuator</u>	Unit Price (\$)_____
No. F	Provide price for replacing a faulty damper actuator	<u>Per damper actuator</u>	Unit Price (\$)_____

The bidder further proposes and agrees hereby to commence work under this contract on a date to be specified in a written order of the designer and shall fully complete all work thereunder within the time specified in the Supplementary General Conditions Article 23. Applicable liquidated damages amount is also stated in the Supplementary General Conditions Article 23.

MINORITY BUSINESS PARTICIPATION REQUIREMENTS

Provide with the bid - Under GS 143-128.2(c) the undersigned bidder shall identify **on its bid** (Identification of Minority Business Participation Form) the minority businesses that it will use on the project with the total dollar value of the bids that will be performed by the minority businesses. **Also** list the good faith efforts (Affidavit **A**) made to solicit minority participation in the bid effort.

NOTE: A contractor that performs all of the work with its own workforce may submit an Affidavit (**B**) to that effect in lieu of Affidavit (**A**) required above. The MB Participation Form must still be submitted even if there is zero participation.

After the bid opening - The Owner will consider all bids and alternates and determine the lowest responsible, responsive bidder. Upon notification of being the apparent low bidder, the bidder shall then file within 72 hours of the notification of being the apparent lowest bidder, the following:

An Affidavit (C) that includes a description of the portion of work to be executed by minority businesses, expressed as a percentage of the total contract price, which is equal to or more than the 10% goal established. This affidavit shall give rise to the presumption that the bidder has made the required good faith effort and Affidavit D is not necessary;

*** OR ***

If less than the 10% goal, Affidavit (D) of its good faith effort to meet the goal shall be provided. The document must include evidence of all good faith efforts that were implemented, including any advertisements, solicitations and other specific actions demonstrating recruitment and selection of minority businesses for participation in the contract.

Note: Bidders must always submit with their bid the Identification of Minority Business Participation Form listing all MB contractors, vendors and suppliers that will be used. If there is no MB participation, then enter none or zero on the form. Affidavit A **or** Affidavit B, as applicable, also must be submitted with the bid. Failure to file a required affidavit or documentation with the bid or after being notified apparent low bidder is grounds for rejection of the bid.

Proposal Signature Page

The undersigned further agrees that in the case of failure on his part to execute the said contract and the bonds within ten (10) consecutive calendar days after being given written notice of the award of contract, the certified check, cash or bid bond accompanying this bid shall be paid into the funds of the owner's account set aside for the project, as liquidated damages for such failure; otherwise the certified check, cash or bid bond accompanying this proposal shall be returned to the undersigned.

Respectfully submitted this day of _____

(Name of firm or corporation making bid)

WITNESS:

(Proprietorship or Partnership)

By: _____
Signature

Name: _____
Print or type

Title _____
(Owner/Partner/Pres./V.Pres)

Address _____

ATTEST:

By: _____

Title: _____
(Corp. Sec. or Asst. Sec. only)

License No. _____

Federal I.D. No. _____

Email Address: _____

(CORPORATE SEAL)

Addendum received and used in computing bid:

Addendum No. 1 _____ Addendum No. 3 _____ Addendum No. 5 _____ Addendum No. 6 _____

Addendum No. 2 _____ Addendum No. 4 _____ Addendum No. 6 _____ Addendum No. 7 _____

ATTACHMENT A

OUTREACH PLAN AND GUIDELINES FOR RECRUITMENT AND SELECTION OF MINORITY BUSINESSES FOR PARTICIPATION IN TOWN BUILDING CONSTRUCTION CONTRACTS

In accordance with G.S. 143-128.2 these guidelines establish goals for minority participation in single-prime bidding, separate-prime bidding, Construction Manager-at-Risk, and alternative contracting methods on Town of Carrboro building construction projects in the amount of \$300,000 or more (\$100,000 or more if the Town receives State funds for the project).

Town of Carrboro's current goal for minority and women-owned participation for public building construction is ten percent (10%) each. The overall goal will be reviewed annually or as soon as relevant data is available.

INTENT

The intent of these guidelines is that the Town of Carrboro, as awarding authority for construction projects, and the contractors and subcontractors performing the construction contracts awarded, shall cooperate and in good faith do all things, legal, proper and reasonable to achieve the goal of ten percent (10%) for participation by minority businesses in each construction project. Nothing in these guidelines shall be construed to require contractors or awarding authorities to award contracts or subcontracts to or to make purchases of materials or equipment from minority-business contractors or minority-business subcontractors who do not submit the lowest responsible, responsive bid or bids.

DEFINITIONS

1. Minority – a person who is a citizen or lawful permanent resident of the United States and who is:
 - a. Black, that is, a person having origins in any of the black racial groups in Africa;
 - b. Hispanic, that is, a person of Spanish or Portuguese culture with origins in Mexico, South or Central American, or the Caribbean Islands, regardless of race;
 - c. Asian American, that is, a person having origins in any of the original peoples of the Far East, Southeast Asia and Asia, the Indian subcontinent, or the Pacific Islands;
 - d. American Indian, that is, a person having origins in any of the original peoples of North America; or
 - e. Female
2. Minority Business – means a business
 - a. In which at least fifty-one percent (51%) of the ownership interest is held by one or more minority persons, or in the case of a corporation, in which at least fifty-one percent (51%) of the stock is owned by one or more minority persons or socially and economically disadvantaged individuals; and

- b. Of which the management and daily business operations are controlled by one or more of the minority persons or socially and economically disadvantaged individuals who own it.
3. *Socially and economically disadvantaged individual* – means the same as defined in 15 U.S.C. 637. “Socially disadvantaged individuals are those who have been subjected to racial or ethnic prejudice or cultural bias because of their identity as a member of a group without regard to their individual qualities”. “Economically disadvantaged individuals are those socially disadvantaged individuals whose ability to compete in the free enterprise system has been impaired due to diminished capital and credit opportunities as compared to others in the same business area who are not socially disadvantaged”.
4. *Public Entity* – means State (and all political subdivisions thereof) and local government units.
5. *Owner* – Town of Carrboro.
6. *Designer* – Any person, firm, partnership, or corporation, which has contracted with Town of Carrboro to perform architectural or engineering work.
7. *Bidder* – Any person, firm, partnership, corporation, association, or joint venture seeking to be awarded a public contract or subcontract.
8. *Contract* – A mutually binding legal relationship, or any modification thereof, obligating the seller to furnish equipment, materials or services, including construction, and obligating the buyer to pay for them.
9. *Contractor* – Any person, firm, partnership, corporation, association, or joint venture which has contracted with the Town of Carrboro to perform construction work or repair.
10. *Subcontractor* – *A firm under contract with the prime contractor or Construction Manager-at-Risk* to supply materials, or labor and materials, and/or installation in connection with a Town building construction or repair contract. The subcontractor may or may not provide materials in the subcontract.

The Town of Carrboro will employ the following strategies to encourage participation from MWBE’s:

1. Work with minority-focused business groups in an attempt to recruit minority business participation in contracts/bids.
2. Emphasize the importance of soliciting certified MWBE firms and small businesses for subcontracting opportunities at pre-bid conferences and in the bid documents. Examine

specifications to identify special subcontracting opportunities and strongly encourage prime contractors to solicit bids for subcontracts from MWBE firms.

3. Provide information to majority contractors concerning the Guidelines for Recruitment and Selection of Minority Business and Outreach Plan and provide information on the procedure for letting of public contracts under G.S. 143-129 by holding meetings with the contractors.
4. Assess the effectiveness of the Outreach Plan by evaluating MWBE participation and compliance and reviewing the “good faith efforts” provided in bid packages.
5. Identify subcontracting opportunities unique to each construction contract and project and concentrate heavily on targeting certified MWBE firms and small businesses that have expressed an interest in Town of Carrboro projects. Identify these opportunities, contact interested businesses no later than 10 days prior to the bid opening, and provide a list of prime contractors planning to participate in the project.
6. Build new business relationships through networking with other North Carolina cities and counties and sharing ideas to improve the Outreach Plan.
7. Offer training sessions to share the Town’s Outreach Plan with interested business organizations.
8. Post the Outreach Plan and Guidelines on the Town’s website, listing good faith efforts, creating links to MWBE resources, and creating awareness of specific subcontracting opportunities.
9. Maintain a database specifically for MWBE firms to ensure that those businesses are notified of bid opportunities.
10. Advertise upcoming bid opportunities in minority-focused media.
11. Work with architects and engineers to make subcontracting opportunities more noticeable and more easily understood by potential contractors and subcontractors.

Designer

Under the single-prime bidding, separate prime bidding, dual bidding, Construction Manager-at-Risk, or alternative contracting method, the Designer must do all of the following:

- a. Attend the scheduled pre-bid conference to explain minority business requirements to the prospective bidders.
- b. Assist the bidders and potential bidders to identify and notify prospective minority business prime and subcontractors of potential contracting opportunities.

- c. Maintain documentation of any contacts, correspondence, or conversations with minority business firms made in an attempt to meet the goals.
- d. Review jointly with the owner all requirements of G.S. 143-128.2(c) and G.S. 143-128.2(f) – (i.e. bidders’ proposal for identification of the minority businesses that will be utilized with corresponding dollar value of the bid and affidavit listing Good Faith Efforts or affidavit of self-performance of work, if the contractor will perform work under contract by its own workforce) – prior to recommendation of an award.
- e. During the construction phase of the project, review “MWBE Documentation for Contract Payment” form with monthly pay applications to the owner and forward copies to the Town of Carrboro.

Prime Contractors(s), CM at Risk and Its First-Tier Subcontractors

Under the single-prime bidding, the separate-prime bidding, dual bidding, Construction Manager-at-Risk and alternative contracting methods, contractor(s) must do all of the following:

- a. Attend the scheduled pre-bid conference.
- b. Identify or determine those subcontractor work areas where minority businesses may have an interest in performing subcontract work.
- c. At least ten (10) days prior to the scheduled day of bid opening, notify minority businesses of potential subcontracting opportunities listed in the proposal. The notification must include all of the following:
 - i. A description of the work for which the sub bid is being solicited.
 - ii. The date, time and location where sub bids are to be submitted.
 - iii. The name of the individual within the company who will be available to answer questions about the project.
 - iv. Where bid documents may be reviewed.
 - v. Any special requirements that may exist, such as insurance, licenses, bonds and financial arrangements.
- d. During the bidding process, comply with the contractor’s requirements listed in the proposal for minority participation.
- e. Identify on the bid the minority businesses that will be utilized on the project with corresponding total dollar value of the bid and affidavit listing good faith efforts as required by G.S. 143-128.2(c) and G.S. 143-128.2(f) or Intent to Perform Contract With Own Workforce affidavit.
- f. Make documentation showing evidence of implementation of Prime Contractor, Construction Manager-at-Risk and First Tier Subcontractor responsibilities available for review by Town of Carrboro upon request.

- g. Provide one of the following upon being named the apparent low bidder: (1) an affidavit (Participation Form) that includes a description of the portion of work to be executed by minority businesses, expressed as a percentage of the total contract price, which is equal to or more than the applicable goal. This affidavit shall give rise to a presumption that the bidder has made the required good faith effort; or (2) if the percentage is not equal to the applicable goal, then documentation of all good faith efforts taken to meet the goal (Good Faith Efforts Questionnaire). The documentation must include evidence of all good faith efforts that were implemented, including any advertisements, solicitations, and evidence of other specific actions demonstrating recruitment and selection of minority businesses for participation in the contract. Failure to comply with these requirements is grounds for rejection of the bid and award to the next lowest responsible and responsive bidder.
- h. Identify the name(s) of minority business subcontractor(s) and corresponding dollar amount of work on the schedule of values.
- i. Submit with each monthly pay requests(s) and final payment(s), “MWBE Documentation for Contract Payment” for Designer’s review.
- j. If at any time during the construction of a project, it becomes necessary to replace a minority business subcontractor, immediately advise the owner in writing of the circumstances involved. The prime contractor shall make a good faith effort to replace a minority business subcontractor with another minority business subcontractor.
- k. Make a good faith effort to solicit sub bids from minority businesses during the construction of a project if additional subcontracting opportunities become available.

Minority Business Responsibilities

Certification

Town of Carrboro does not certify minority, disadvantaged or woman-owned businesses. Any business which desires to participate as an MWBE will be required to complete, and submit for certification, documents required by the agencies listed below. Only those firms holding current certification through at least one of the following agencies will be considered eligible for inclusion in meeting the MWBE participation percentage goals:

1. North Carolina Administration Department Historically Underutilized Business (HUB) certification.
2. North Carolina Department of Transportation Minority/Disadvantage/Woman-owned Business certification.
3. Small Business Administration 8(a) certification.
4. Other governmental agencies on a case-by-case basis.

A copy of these guidelines will be issued with each bid package for Town of Carrboro building construction projects. These guidelines shall apply to all contractors regardless of ownership.

Other Responsibilities

Minority businesses that are contacted by owners or bidders must respond promptly whether or not they wish to participate in the bidding.

MINIMUM MWBE COMPLIANCE REQUIREMENTS

All written statements, affidavits or intentions made by the Bidder shall become a part of the agreement between the Contractor and Town of Carrboro for the performance of the contract. Failure to comply with any of these statements, affidavits or intentions, or with the minority business guidelines shall constitute a breach of contract. A finding by the Town that any information, submitted either prior to award of the contract or during the performance of the contract, is inaccurate, false or incomplete, shall constitute a breach of the contract. Any such breach may result in termination of the contract in accordance with the termination provisions contained in the contract. The Town of Carrboro shall determine, in the exercise of its sole discretion, whether to terminate the contract for breach.

In determining whether a contractor has made Good Faith Efforts, the Town of Carrboro will evaluate all efforts made by the Contractor and will determine compliance in regard to quantity, intensity, and results of these efforts. Bidders must earn at least 50 points from the good faith efforts listed below in order for their bids to be considered responsive:

1. Contacting those minority businesses reasonably expected to submit a quote and known or identified to the contractor, or available on State or local government maintained lists, at least 10 days before the bid or proposal date and notifying them of the nature and scope of the work to be performed. (Value = 10 points)
2. Making the construction plans, specifications and requirements available for review by prospective minority businesses, or providing these documents to them at least 10 days before the bid or proposals are due. (Value = 10 points)
3. Breaking down or combining elements of work in economically feasible units to facilitate minority participation. (Value = 15 points)
4. Working with minority trade, community, or contractor organizations identified by the Office for Historically Underutilized Businesses and those included in the bid documents to provide assistance in recruitment of minority businesses. (Value = 10 points)
5. Attending any pre-bid meetings scheduled by the public owner. (Value = 10 points)

6. Providing assistance in obtaining required bonding or insurance, or providing alternatives to bonding or insurance for subcontractors. (Value = 20 points)
7. Negotiating in good faith with interested minority businesses and not rejecting them as unqualified without sound reasons based on their capabilities. Any rejection of a minority business based on lack of qualification shall have the reasons documented in writing. (Value = 15 points)
8. Providing assistance to an otherwise qualified minority business in need of equipment, loan capital, lines of credit, or joint pay agreements to secure loans, supplies, or letters of credit, including waiving credit that is ordinarily required. Assisting minority businesses in obtaining the same unit pricing with the bidder's suppliers in order to help minority businesses in establishing credit. (Value = 25 points)
9. Negotiating joint venture and partnership arrangements with minority businesses in order to increase opportunities for minority business participation on a public building construction or repair project when possible. (Value = 20 points)
10. Providing quick pay agreements and policies to enable minority contractors and suppliers to meet cash-flow demands. (Value = 20 points)

Failure to file a required affidavit or document demonstrating that the contractor made the required good faith effort is grounds for rejection of the bid.

DISPUTE RESOLUTION PROCEDURES

Pursuant to G.S. 143-128(f1), all disputes involving contractors on a building construction project with the Town of Carrboro shall be resolved pursuant to the State of North Carolina Policy G.S. 143-135.26(11).

ATTACHMENT B

Town of Carrboro Good Faith Effort Questionnaire

In the Town's Purchasing Policy and Contract Procedures Handbook, bidders are to be evaluated on Good Faith Efforts to recruit and select Minority/Women-owned Business Enterprises (M/WBE) for participation in construction contracts. Bidders must earn at least 50 points for good faith efforts for their bid(s) to be considered responsive.

The list of questions in Appendix A: *Outreach Plan and Guidelines for Recruitment and Selection of Minority Businesses for Participation in Town Building Construction Contract*, is the tool used for this evaluation. This questionnaire should be completed with assigned point values for each bidder. *(Note: If a bidder provides documentation with a bid that the M/WBE goals for the project will be attained, then it is not necessary to complete this questionnaire.)*

-
1. Did you contact those minority businesses reasonably expected to submit a quote and known or identified to the contractor, or available on State or local government maintained lists, at least 10 days before the bid or proposal date and notifying them of the nature and scope of the work to be performed? (Value = 10 points)
 2. Did you make the construction plans, specifications and requirements available for review by prospective minority businesses, or provide these documents to them at least 10 days before the bid or proposals are due? (Value = 10 points)
 3. Did you break down or combine elements of work in economically feasible units to facilitate minority participation? (Value = 15 points)
 4. Did you work with minority trade, community, or contractor organizations identified by the Office for Historically Underutilized Businesses and those included in the bid documents to provide assistance in recruitment of minority businesses? (Value = 10 points)
 5. Did you attend any pre-bid meetings scheduled by the public owner. (Value = 10 points)
 6. Did you provide assistance in obtaining required bonding or insurance, or provide alternatives to bonding or insurance for subcontractors. (Value = 20 points)
 7. Have you negotiated in good faith with interested minority businesses and not rejecting them as unqualified without sound reasons based on their capabilities? Any rejection of a minority business based on lack of qualification shall have the reasons documented in writing. (Value = 15 points)

8. Have you provided assistance to an otherwise qualified minority business in need of equipment, loan capital, lines of credit, or joint pay agreements to secure loans, supplies, or letters of credit, including waiving credit that is ordinarily required? Assisting minority businesses in obtaining the same unit pricing with the bidder's suppliers in order to help minority businesses in establishing credit. (Value = 25 points)
9. Have you negotiated any joint venture and partnership arrangements with minority businesses in order to increase opportunities for minority business participation on a public building construction or repair project when possible? (Value = 20 points)
10. Have you provided quick pay agreements and policies to enable minority contractors and suppliers to meet cash-flow demands. Value = 20 points)

Failure to file a required affidavit or submit this questionnaire demonstrating that the contractor made a good faith effort is grounds for rejection of the bid.

ATTACHMENT C

Town of Carrboro M/WB Participation on Base Bid

Name of Bidder: _____

Total dollar amount of M/WBE participation in base bid work: *or each row, check one column: E or F*

Column A	Column B	Column C	Column D	Column E	Column F
Name of proposed subcontractor for base bid work	Goods and services to be provided for base bid work	Subcontract amount, in dollars, for base bid work	Percentage of total base bid (Column C divided by total base bid)	Minority-owned UBE	Women-owned UBE
		\$	%		
		\$	%		
		\$	%		
		\$	%		

Attach extra sheets as needed.

Do the above participation amounts meet the established goals on this contract assuming only the base bid is counted?

Yes No

If the answer is No, then (a) the bidder must have made good-faith efforts; (b) the bidder must provide, within 2 business days after bid opening, documentation of good-faith efforts; and (c) the bidder must sign below.

As an authorized representative of the Bidder, I swear or affirm under penalty of fraud that the good-faith efforts documentation submitted with this bid, pertaining to the base bid and all alternates, if any, is correct and not intended to defraud or mislead. After the contract between the Town and the Bidder is signed, except to the extent that the Town gives prior written approval for changes, the Contractor agrees that it shall engage the subcontractors listed on this form and on all applicable forms, to perform the work for the dollar amounts or percentages described on this applicable form.

Signature of Individual authorized to sign for Bidder

DIVISION 01

GENERAL REQUIREMENTS

SUMMARY OF THE WORK

PART 1 - GENERAL

1.01 RELATED DOCUMENTS

- A. Drawings, Notice to Bidders and Standard General Conditions of the Construction Contract, including Supplementary General Conditions and Division 01 Specification sections, apply to work of this section.

1.02 PROJECT/WORK IDENTIFICATION

- A. General: Project name is "Century Center Chiller Replacement and DDC Controls Upgrade", Town of Carrboro, Carrboro, NC., as shown on Contract Documents prepared by Sud Associates, P.A. Drawings and Specifications are dated February 22, 2024.
- B. Contract Documents: Indicate the work of the Contract and related requirements and conditions that have an impact on the project. Related requirements and conditions that are indicated on the Contract Documents include, but are not necessarily limited to, the following:
 1. Existing site conditions and restrictions on use of the site.
 2. Work performed prior to work under this Contract.
 3. Alterations and coordination with the existing building.
 4. Installation of a new air-cooled chiller that was pre-purchased by the Owner.
 5. Work to be performed concurrently by others.

1.03 SCOPE

- A. A summary of the Scope of Work of this project is given at the end of this section.
- B. Summary by References: Work of the Contract can be summarized by references to the Contract, General Conditions, Supplementary Conditions, Specification Sections, Drawings, addenda and modifications to the contract documents issued subsequent to the initial printing of this project manual and including, but not necessarily limited to, printed material referenced by any of these. It is recognized that work of the Contract is also unavoidably affected or influenced by governing regulations, natural phenomenon including weather conditions and other forces outside the contract documents.

1.04 CONTRACTOR USE OF PREMISES

- A. General: The Contractor shall limit his use of the premises to the work indicated, so as to allow for Owner occupancy and use.
- B. Use of the Site: Confine operations at the site to the areas permitted under the Contract. Portions of the site beyond areas on which work is indicated are not to be disturbed. Conform to site rules and regulations affecting the work while engaged in project construction.

Keep existing driveways and entrances serving the premises clear and available to the Owner and his employees at all times. Do not use these areas for parking or storage of materials.

Do not unreasonably encumber the site with materials or equipment. Confine stockpiling of materials and location of storage sheds to the areas indicated. If additional storage is necessary, obtain and pay for such storage off site.

Lock automotive type vehicles, such as passenger cars and trucks and other mechanized or motorized construction equipment, when parked and unattended, so as to prevent unauthorized use. Do not leave such

vehicles or equipment unattended with the motor running or the ignition key in place.

- C. Contractor Use of the Existing Building: Maintain the existing building in a safe and weather tight condition throughout the construction period. Repair damage caused by construction operations. Take all precautions necessary to protect the building and its occupants during the construction period.

Smoking or open fires will not be permitted within the building enclosure or on the premises.

1.05 ASBESTOS

- A. It is not expected that any asbestos containing materials will be disturbed or found during the project work.
- B. The scope of work covered under this project shall not include asbestos removal or any other asbestos-related work.
- C. Prior to commencing any work, the Contractor shall thoroughly examine all parts of the buildings affected by his work for possible presence of asbestos. The Contractor shall precisely identify the locations where he suspects his work will potentially disturb the existing asbestos. The Owner shall examine these locations for the presence of asbestos. If any of these locations contain asbestos, the Owner shall arrange for the removal of a sufficient amount of the asbestos-containing material to permit installation of the work by the Contractor without disturbing the asbestos.
- D. The Owner shall be responsible for the removal of only that amount of asbestos-containing material that is initially identified by the Contractor in accordance with the procedure outlined above. Any asbestos removal required in excess of that initially identified shall be through a properly executed change order and at no cost to the Owner. Any such removal shall meet all applicable laws, rules and regulations.
- E. If a contractor encounters some material which he is not sure if it is asbestos, work must not begin until it is verified through the Owner.
- F. The asbestos materials must not be disturbed in any way by the Contractor. If any is disturbed, the Contractor responsible for the disturbance will be responsible for the cost of the clean-up by an accredited asbestos abatement contractor and decontamination of all areas contaminated by the asbestos disturbance.
- G. The time required by the Owner for the removal of asbestos is not included in the specified time of completion for the contract.

1.06 OWNER OCCUPANCY

Construction on this project will be completed by the dates specified in the Supplementary General Conditions. The building will be occupied during portions of the construction period by students and staff. The College reserves the right to undertake work by other contractors or in-house during the construction period. Contractor will cooperate and coordinate. Except for specific interruptions permitted by the College, pedestrian and vehicular traffic shall be maintained continuously during the construction period.

The contractor shall coordinate with the Owner to allow the other activities in the building. He shall be responsible for securing his work area and for the safety of his workers and other occupants of the building.

1.07 DISCREPANCIES IN DRAWINGS AND SPECIFICATIONS

Should the Contractor find discrepancies or ambiguities in, or omissions from, the Drawings or Specifications, or should he be in doubt as to their meaning, he shall at once notify the Engineer, who will issue an interpretation.

1.08 ALTERATIONS AND COORDINATION

- A. General: The work of this Contract includes coordination of the entire work of the project, including

preparation of general coordination drawings, diagrams and schedules, and control of site utilization, from beginning of construction activity through project closeout and warranty periods.

- B. Electrical Requirements: Except as otherwise indicated, comply with applicable provisions of The National Electrical Code (NEC) and standards by National Electrical Manufacturer's Association (NEMA), for electrical components of general work.
- C. Provide Underwriters Laboratories listed and labeled products where applicable.

1.09 COMPLIANCE WITH FEDERAL AND STATE LAWS AND REGULATIONS

- A. General: Contractor including his subcontractors shall comply with all applicable federal, state and local laws and regulations.
- B. Administrative Requirements: The Contractor shall provide any documents required to comply with administrative and legal requirements. These include summary reports of sales tax and other assessments, as requested by the Owner, etc.
- C. Certificates:
 - 1. Inspection Certificates: It shall be the responsibility of the Contractor to request and coordinate inspections. Obtain all inspection certificates required by law, ordinances, rules and regulations of the Authorities having jurisdiction. Provide the Engineer certificates of such inspections, pay all fees, charges, and other expenses in connection therewith, prior to final payment.
 - 2. Final payment will be made within thirty (30) consecutive days after acceptance of the work and the submission of notarized contractor's affidavit and letter certifying that no hazardous materials were introduced. The contractor's affidavit shall state: "This is to certify that all costs of materials, equipment, labor, and all else entering into the accomplishment of this contract, including payrolls, have been paid in full." The contractor's certification letter shall state: "This is to certify that no hazardous materials, including lead, asbestos, or PCBs were introduced into the building during the course of this project. If it is discovered at a later date that an asbestos-containing product or hazardous material was used, (name of contractor) will remove it and restore the project to its original working condition at no cost to the Owner."

1.10 COOPERATION WITH CITY GOVERNMENT

- A. The Contractor shall cooperate with the Administration of the City/County and at all times shall endeavor to permit normal movement of vehicle and pedestrian traffic.

1.11 SPECIAL REQUIREMENT

- A. Interruption of Utilities.
 - 1. This building will be occupied during portions of the construction and the adjacent building will be occupied during construction. Any interruption of utilities (electricity, water, heating, cooling, etc.) shall be minimized and undertaken through the owner with at least 5 days advanced notice. If necessary, work must be done at night, or over the weekend, or during holidays to minimize interruptions. No extra payment will be made for such work.
- B. Access to Buildings.
 - 1. The owner will make necessary arrangements for access to the premises. Coordinate with the Owner for all locked areas. It is the Contractor's responsibility to see that no un-authorized person gains access to construction areas. The Contractor shall coordinate with the Owner if access is required beyond normal working hours.

- C. Employee Conduct.

1. At any time during the construction and completion of the work covered by these specifications, if the conduct of any workman of the various crafts be adjudged ungentlemanly and a nuisance to the Owner or Engineer or if any workman be considered incompetent or detrimental to the work, the Contractor shall order such parties removed immediately from the grounds.

1.12 EXAMINATION OF PREMISES

- A. Each Bidder prior to submitting a proposal shall examine the site and all conditions thereon. All proposals will be presumed to include all such existing conditions as may affect any work of this project; and failure to familiarize himself with any such conditions will in no way relieve the successful bidder from the necessity of furnishing all materials or performing any work that may be required to complete the work in accordance with the drawings and specifications, without additional cost to the Owner. Examination of premises shall be scheduled, by prior appointment only, with:

Mr. Keith Berger
Telephone: 919-918-7432

1.13 CORRESPONDENCE TO THE OWNER AND ENGINEER

- A. All papers required to be delivered to the Owner shall, unless otherwise directed in writing to the Contractor, be delivered to Sud Associates, P.A., 1813 Chapel Hill Road, Durham, North Carolina 27707. A copy of these papers shall also be sent to the owner, in care of Mr. Keith Berger, Town of Carrboro, 100 Public Works Drive, Carrboro, NC 27510.
- B. Copies of correspondence to the Engineer shall be sent to the Owner, in care of Mr. Keith Berger, Town of Carrboro, 100 Public Works Drive, Carrboro, NC 27510.
- C. To the extent possible, communications shall be via e-mail with the Owner and Engineer being copied.
 1. The Owner's e-mail address is: cberger@carrboronc.gov.
 2. The Engineer's e-mail address is: ddavis@sudassociates.com.

1.14 PARKING REQUIREMENT

- A. The contractor shall consult with the Owner for permissible parking locations and at all times shall endeavor to permit normal movement of vehicle and pedestrian traffic near the job site. The Contractor shall also coordinate with the Owner for location of site trailer if one is required.

1.15 THE CONTRACT DOCUMENTS

- A. The Contract Documents consist of Notice to Bidders, Standard General Conditions of the Construction Contract, Supplementary General Conditions, all sections of Division 1, the Drawings, and Specifications, including all bulletins, addenda, or other modifications of the Drawings and Specifications incorporated into the documents prior to their execution, the Proposal Form and supporting information submitted by the Contractor, the Contract Form, the Payment and Performance Bonds, Power of Attorney, and Insurance Certificates evidencing the needed coverages. All of these items together form the Contract Documents.
- B. The contract will be awarded to the lowest responsible bidder for the entire work covered under this contract. Prior to contract award, the Contractor will be required to provide cost breakdowns requested by the Owner, any certifications (Debarment, etc.) and any documents required to comply with legal and/or Grant requirements. Summary reports of sales tax and other assessments, as requested by the Owner, shall also be provided.

1.16 COMPLIANCE WITH MINORITY BUSINESS PARTICIPATION POLICY

See additional requirements listed separately.

PART 2 - PRODUCTS (Not applicable)

PART 3 - EXECUTION (Not applicable)

END OF SECTION 01 01 00

TOWN OF CARRBORO
CENTURY CENTER CHILLER REPLACEMENT
AND DDC CONTROLS UPGRADE

Intent: It is the intention of the Specifications, Drawings, and Contract Documents, to replace major HVAC equipment and DDC controls with new equipment and DDC controls. This work shall include removal of one air-cooled chiller, two pumps, DDC front-end and network, DDC controllers with integral actuators on 35 VAV boxes, and control valves on 3 air handlers. The work shall include taking possession of, delivering, and installing a new air-cooled chiller pre-purchased by the owner, providing two new pumps, DDC controllers with integral actuators for 35 VAV boxes, control valves for 3 air handlers, and all electrical, plumbing, ductwork, piping, controls, fire alarm, painting, patching, etc. for a complete job. The scope includes all work indicated or implied by the drawings and specifications. It includes all items that may not be specifically shown but are required for a complete and finished job or may be required by codes or regulations. Work on this project will be covered by a Single Prime Contract. The contractors shall coordinate their work. The Prime Contractor will be responsible for getting the general construction, mechanical, plumbing, electrical and other specialty work done by properly licensed Sub-contractors approved by the Owner. The scope of work under each contract includes, but is not limited to the following:

General:

1. Performance of all ancillary general construction work, such as installing house-keeping pads, pipe hangers, etc., needed for the project.
2. Removal and reinstallation of existing acoustic ceiling tiles as needed to accommodate the work.
3. Repair any damage to building components caused by removal of equipment and installation of new equipment.

Plumbing:

1. Verify existing floor drains are not clogged and clear them out if they are clogged.

Mechanical:

1. Remove one air-cooled chiller and prepare existing support rails for new chiller. Pick up air-cooled chiller that was pre-purchased by owner and is stored at an off-site location, deliver it to the construction site, install it, and be responsible for assisting chiller manufacturer with start-up and owner training, and be responsible for start date of warranty.
2. Replace one chilled water pump with one that is controlled by ASD (adjustable speed drive).
3. Replace one hot water pump with one that is balanced by ASD (adjustable speed drive).
4. Replace 3-way chilled water control valves on 3 air handlers with 2-way valves, and add a by-pass valve arrangement.
5. Replace DDC controllers with integral damper actuators on 35 VAV boxes with new DDC controllers with integral damper actuators.
6. Remove existing DDC thermostats and replace them with new DDC thermostats.
7. Provide new piping, pipe insulation, and ancillaries as indicated for a complete job.
8. Provide cleaning of piping and provide chemical feeders and treatment on hot and chilled water systems.
9. Test and balance air and water systems.

Electrical:

1. Disconnect the power from the existing equipment being removed.
2. Demolish electrical equipment that is not being re-used.
3. Provide power for new HVAC equipment, including conductors between the existing chiller disconnect and the new chiller, and a new circuit and breaker for heat trace.
4. Provide new conductors and breakers for two pumps.
5. Coordinate, schedule and conduct electrical inspections with the AHJ.

Alternates:

1. Owner Preferred Alternate No. OP-M1: Provide DDC controls by Honeywell Building Technologies, subject to compliance with the requirements of the specifications.

The building must remain in operation throughout the period of construction. All services to it (water, electricity, etc.) must be operational with only brief interruptions.

Sequence of Construction

The contractor shall submit a construction sequence which meets the intent of accomplishing the construction within the planned time period. The owner will be occupying the building throughout the construction period. Work is expected to occur during normal business hours, with the exception of up to 6 VAV boxes which may require after-hours work for the controls upgrade. The intent is to replace the chiller during the heating season, with chiller startup occurring no later than March 1, 2025.

PART 1 - GENERAL

1.01 RELATED DOCUMENTS

- A. Drawings and general provisions of the Contract, including General and Supplementary Conditions and other Division 01 Specification Sections, apply to this Section.

1.02 SUMMARY

- A. Section includes administrative and procedural requirements governing allowances.
 - 1. Certain items are specified in the Contract Documents by allowances. Allowances have been established in lieu of additional requirements and to defer selection of actual materials and equipment to a later date when direction will be provided to Contractor. If necessary, additional requirements will be issued by Change Order.
- B. Types of allowances include the following:
 - 1. Lump-sum allowances.
 - 2. Contingency allowances.
 - 3. Testing and inspecting allowances.
- C. Related Requirements:
 - 1. Division 01 Section "Unit Prices" for procedures for using unit prices.
 - 2. Division 01 Section "Quality Requirements" for procedures governing the use of allowances for testing and inspecting.
 - 3. Divisions 02 through 33 Sections for items of Work covered by allowances.

1.03 SELECTION AND PURCHASE

- A. At the earliest practical date after award of the Contract, advise Architect of the date when final selection and purchase of each product or system described by an allowance must be completed to avoid delaying the Work.
- B. At Architect's request, obtain proposals for each allowance for use in making final selections. Include recommendations that are relevant to performing the Work.
- C. Purchase products and systems selected by Architect from the designated supplier.

1.04 ACTION SUBMITTALS

- A. Submit proposals for purchase of products or systems included in allowances, in the form specified for Change Orders.

1.05 INFORMATIONAL SUBMITTALS

- A. Submit invoices or delivery slips to show actual quantities of materials delivered to the site for use in fulfillment of each allowance.
- B. Submit time sheets and other documentation to show labor time and cost for installation of allowance items that include installation as part of the allowance.

- C. Coordinate and process submittals for allowance items in same manner as for other portions of the Work.

1.06 COORDINATION

- A. Coordinate allowance items with other portions of the Work. Furnish templates as required to coordinate installation.

1.07 LUMP-SUM ALLOWANCES

- A. Allowance shall include cost to Contractor of specific products and materials ordered by Owner or selected by Architect under allowance and shall include **taxes**, freight, and delivery to Project site.
- B. Unless otherwise indicated, Contractor's costs for receiving and handling at Project site, labor, installation, overhead and profit, and similar costs related to products and materials under allowance shall be included as part of the Contract Sum and not part of the allowance.
- C. Unused Materials: Return unused materials purchased under an allowance to manufacturer or supplier for credit to Owner, after installation has been completed and accepted.
 - 1. If requested by Architect, retain and prepare unused material for storage by Owner. Deliver unused material to Owner's storage space as directed.

1.08 CONTINGENCY ALLOWANCES

- A. Use the contingency allowance only as directed by Designer for Owner's purposes and only by Change Orders that indicate amounts to be charged to the allowance.
- B. Change Orders authorizing use of funds from the contingency allowance will include Contractor's related costs and reasonable overhead and profit margins.
- C. At Project closeout, credit unused amounts remaining in the contingency allowance to Owner by Change Order.

1.09 TESTING AND INSPECTING ALLOWANCES

- A. Testing and inspecting allowances include the cost of engaging testing agencies, actual tests and inspections, and reporting results.
- B. The allowance does not include incidental labor required to assist the testing agency or costs for retesting if previous tests and inspections result in failure. The cost for incidental labor to assist the testing agency shall be included in the Contract Sum.
- C. Costs of services not required by the Contract Documents are not included in the allowance.
- D. At Project closeout, credit unused amounts remaining in the testing and inspecting allowance to Owner by Change Order.

1.10 ADJUSTMENT OF ALLOWANCES

- A. Allowance Adjustment: To adjust allowance amounts, prepare a Change Order proposal based on the difference between purchase amount and the allowance, multiplied by final measurement of work-in-place where applicable. If applicable, include reasonable allowances for cutting losses, tolerances, mixing wastes, normal product imperfections, and similar margins.
 - 1. Include installation costs in purchase amount only where indicated as part of the allowance.
 - 2. If requested, prepare explanation and documentation to substantiate distribution of overhead costs and other margins claimed.

3. Submit substantiation of a change in scope of work, if any, claimed in Change Orders related to unit-cost allowances.
 4. Owner reserves the right to establish the quantity of work-in-place by independent quantity survey, measure, or count.
- B. Submit claims for increased costs because of a change in scope or nature of the allowance described in the Contract Documents, whether for the purchase order amount or Contractor's handling, labor, installation, overhead, and profit.
1. Do not include Contractor's or subcontractor's indirect expense in the Change Order cost amount unless it is clearly shown that the nature or extent of work has changed from what could have been foreseen from information in the Contract Documents.
 2. No change to Contractor's indirect expense is permitted for selection of higher- or lower-priced materials or systems of the same scope and nature as originally indicated.

PART 2 - PRODUCTS (Not Used)

PART 3 - EXECUTION

3.01 EXAMINATION

- A. Examine products covered by an allowance promptly on delivery for damage or defects. Return damaged or defective products to manufacturer for replacement.

3.02 PREPARATION

- A. Coordinate materials and their installation for each allowance with related materials and installations to ensure that each allowance item is completely integrated and interfaced with related work.

3.03 SCHEDULE OF ALLOWANCES

Allowance No. 1: CONTINGENCY ALLOWANCE

Allowance for replacing existing devices found to be faulty	
Allowance Amount Base Bid	= \$30,000.00

END OF SECTION 01 21 00

PART 1 - GENERAL

1.01 RELATED DOCUMENTS

- A. Drawings and general provisions of the Contract, including General Conditions and other Division 1 Specification Sections, apply to this Section.

1.02 SUMMARY

- A. This Section includes administrative and procedural requirements for unit prices.
- B. Related Sections include the following:
 - 1. Division 1 Section 012100 "Allowances" for procedures for using unit prices to adjust quantity allowances.

1.03 DEFINITIONS

- A. Unit price is an amount proposed by bidders, stated on the Bid Form, as a price per unit of measurement for materials or services added to or deducted from the Contract Sum by appropriate modification, if estimated quantities of Work required by the Contract Documents are increased or decreased.

1.04 GENERAL

- A. Unit prices quoted and accepted shall apply throughout the life of the contract, except as otherwise specifically noted. Unit prices shall be applied, as appropriate, to compute the total value of changes in the scope of the work, all in accordance with the contract documents. Single Prime Proposals are to include all Unit Prices listed in this Specification Section

1.05 PROCEDURES

- A. Unit prices include all necessary material, plus cost for delivery, installation, insurance, overhead, and profit.
- B. Measurement and Payment: Refer to individual Specification Sections for work that requires establishment of unit prices. Methods of measurement and payment for unit prices are specified in those Sections.
- C. Owner reserves the right to reject Contractor's measurement of work-in-place that involves use of established unit prices and to have this work measured, at Owner's expense, by an independent surveyor acceptable to Contractor.
- D. List of Unit Prices: A list of unit prices is included at the end of this Section. Specification Sections referenced in the schedule contain requirements for materials described under each unit price.

PART 2 – PRODUCTS (Not Used)**PART 3 - EXECUTION**

3.01 LIST OF UNIT PRICES

Note: Unit Prices listed below are also listed on the Single Prime Bid Form. Unit Prices of the successful Bidders will become part of the Contract.

Mechanical

	<u>Description</u>	<u>Unit</u>
A.	Provide price for replacing a faulty water control valve (1/2" through 1").	Per valve
B.	Provide price for replacing a faulty water control valve (1-1/4" through 2").	Per valve
C.	Provide price for replacing a faulty control damper.	Per square foot of damper
D.	Provide price for replacing a faulty valve actuator for 1/2" through 1".	Per valve actuator
E.	Provide price for replacing a faulty valve actuator for 1-1/4" through 2".	Per valve actuator
F.	Provide price for replacing a faulty damper actuator.	Per damper actuator

END OF SECTION 01 22 00

PART 1 - GENERAL

.01 RELATED DOCUMENTS

- A. Drawings and general provisions of the Contract, including General Conditions and other Division 01 Specification Sections, apply to this Section.

1.02 SUMMARY

- A. This Section includes administrative and procedural requirements for alternates.

1.03 GENERAL

- A. All work under this heading is subject to all Contract Documents, and includes the furnishing of all labor, materials, equipment, accessories, etc. for the complete installation of all Alternates as outlined in this Specification Section.
- B. The owner shall retain the right to accept an alternate after construction has begun, provided it does not cause rework of construction already installed.

1.04 DEFINITIONS

- A. Alternate: An amount proposed by bidders and stated on the Bid Form for certain work defined in the Bidding Requirements that may be added to or deducted from the Base Bid amount if Owner decides to accept a corresponding change either in the amount of construction to be completed or in the products, materials, equipment, systems, or installation methods described in the Contract Documents.
 - 1. The cost or credit for each alternate is the net addition to or deduction from the Contract Sum to incorporate alternate into the Work. No other adjustments are made to the Contract Sum.

1.05 PROCEDURES

- A. Coordination: Modify or adjust affected adjacent work as necessary to completely integrate work of the alternate into Project.
 - 1. Include as part of each alternate, miscellaneous devices, accessory objects, and similar items incidental to or required for a complete installation whether or not indicated as part of alternate.
- B. Notification: Immediately following award of the Contract, notify each party involved, in writing, of the status of each alternate. Indicate if alternates have been accepted, rejected, or deferred for later consideration. Include a complete description of negotiated modifications to alternates.
- C. Execute accepted alternates under the same conditions as other work of the Contract.
- D. Schedule: A Schedule of Alternates is included at the end of this Section. Specification Sections referenced in schedule contain requirements for materials necessary to achieve the work described under each alternate.

PART 2 – PRODUCTS (Not Used)

PART 3 – EXECUTION

3.01 SCHEDULE OF ALTERNATES

A. Alternate prices are requested as listed in this section; prices shall be gross, inclusive of all incidental cost adjustments related to the work being priced. Omissions of items required for a complete installation of the alternate shall be the responsibility of the General Contractor; no adjustment will be made after acceptance of the alternate as part of the Contract Price. Single Prime Bidders shall furnish total price inclusive of all trades under the General category. The Owner reserves the right to accept or reject any or all alternate prices; the order of listing on the Bid Form does not reflect a priority for acceptance by the Owner. Note that some alternates may constitute entire sections of these specifications; accepted alternates shall be governed by all applicable provisions of the Contract Documents unless specified otherwise.

1. **Owner Preferred Alternate No. OP-M1:** Provide DDC controls by Honeywell Building Technologies, subject to compliance with the requirements of the specifications.

END OF SECTION 01 23 00

PAYMENT PROCEDURES

PART 1 - GENERAL

1.01 RELATED DOCUMENTS:

- A. Drawings, Notice to Bidders and Standard General Conditions of the Construction Contract, including Supplementary General Conditions and Division-1 Specification Sections, apply to work of this section.

PART 2 - PRODUCTS (Not Applicable)**PART 3 - EXECUTION**

- A. Requests for Payment shall be submitted in three copies with original signatures, properly notarized, on AIA Documents G702 and G703, 1992 summer edition. Summary Statement of Sales and Use Tax shall be submitted on a quarterly basis in accordance with NC General Statutes.
- B. Each subcontractor shall coordinate preparation of Schedule of Values with preparation of the Construction Schedule.
- C. Submit the Schedule of Values to the Engineer and Owner at the earliest feasible date, but in no case later than 21 days before the date scheduled for submittal of the initial Application for Payment.
- D. Format and Content: Use the Project Manual Table of Contents as a guide to establish the format for the Schedule of Values. Round off to the nearest whole dollar; the total shall equal the contract sum.
- E. Schedule Updating: When Change Orders result in a change in the Contract Sum, add these to the Schedule of Values as a separate line item.
- F. At least 30 days prior to final inspection, the Contractor shall provide operating and maintenance information and instructions for equipment and systems provided under the Contract and as specified below.
- G. Furnish such information and instructions for each item that will require any adjustment, servicing, or attention for its proper operations. The instructions shall give the information which is necessary for the Owner to operate at maximum efficiency and perform maintenance and servicing that is normally performed by the Owner. Include a complete maintenance schedule listing all suggested maintenance procedures and the interval of time at which each procedure should be repeated. The instructions shall be written in simple, non-technical language, when possible, with sufficient drawings where necessary to be readily understandable by the average layman. Possible hazards shall be particularly pointed out and include instructions cautioning against mistakes in operations that might result in damage or danger to equipment, building, or personnel.
- H. Two (2) copies of instructions shall be submitted to the Engineer for review and approval, one (1) copy of which shall be returned to the Contractor approved or with instructions for changes. Upon approval by the Engineer, three (3) additional copies of instructions covering all equipment shall be furnished to the Engineer.
- I. In addition to the above-mentioned instructions, the Contractor shall furnish to Engineer three (3) copies of manufacturer's literature for each item of fire protection and electrical equipment installed. Notation shall be written in literature indicating how the particular item was used and its location. This information will be used by the Owner as an aid in future servicing of equipment with sufficient detail to serve this purpose.
- J. After submission of the above-mentioned written instructions (and prior to turning equipment over to the Owner), the Contractor shall furnish competent operations Engineer or Engineers to meet with Owner for the

purpose of discussing all equipment and all phases of its operation and maintenance. The amount of time devoted to instructions shall be reasonable and consistent with the size of the installation and the complexity thereof. Instructions should be adequate to the extent that the Owner may proceed with normal operations in a safe and efficient manner.

END OF SECTION 01 29 00

PART 1 - GENERAL

1.01 RELATED DOCUMENTS:

- A. Drawings, Notice to Bidders and Standard General Conditions of the Construction Contract, including Supplementary General Conditions and Division 01 Specification sections, apply to work of this section.

1.02 DESCRIPTION OF WORK:

- A. Minimum administrative and supervisory requirements necessary for coordination of work on the project include but are not necessarily limited to the following:
 - 1. Coordination and meetings.
 - 2. Administrative and supervisory personnel.
 - 3. Limitations for use of site.
 - 4. Special reports.
 - 5. General installation provisions.
 - 6. Cleaning and protection.
 - 7. Conservation and salvage.

1.03 LIMITATIONS ON USE OF THE SITE:

- A. General: Limitations on site usage as well as specific requirements that impact site utilization are indicated on the drawings and by other contract documents. In addition to these limitations and requirements, administer allocation of available space equitably among entities needing both access and space so as to produce the best overall efficiency in performance of the total work of the project. Schedule deliveries so as to minimize space and time requirements for storage of materials and equipment on site.
- B. Burial of Waste Materials: Do not dispose of organic and hazardous materials on site, either by burial or by burning.
- C. Disposal: Owner shall identify any demolished items removed from the structures that he wants to retain. All such items shall be delivered to the Owner in accordance with his instructions. The contractor shall remove from site all other demolished items (i.e. mechanical equipment, lighting fixtures, wire, etc.) Removed from the structures and dispose of them by legal means. The Contractor will assume full liability for the disposal of all demolished items removed from the site.

1.04 SPECIAL REPORTS:

- A. General: Submit special reports directly to the Owner within one day of an occurrence. Submit a copy of the report to the Designer and other entities that are affected by the occurrence.
- B. Reporting Unusual Events: When an event of an unusual and significant nature occurs at the site, prepare and submit a special report. List chain of events, persons participating, response by the Contractor's personnel, an evaluation of the results or effects and similar pertinent information. Advise the Owner in advance when such events are known or predictable.

PART 2 - PRODUCTS (NOT APPLICABLE)

PART 3 - EXECUTION

- 3.01 Installer's Inspection of Conditions: Require the Installer of each major unit of work to inspect the substrate

to receive work and conditions under which the work is to be performed. The Installer shall report all unsatisfactory conditions in writing to the Contractor. Do not proceed with the work until satisfactory conditions have been corrected in a manner acceptable to the Installer.

- 3.02 Manufacturer's Instructions: Where installations include manufactured products, comply with the manufacturer's applicable instructions and recommendations for installation, to the extent that these instructions and recommendations are more explicit or more stringent than the requirements indicated in the contract documents.
- 3.03 Inspect each item of materials or equipment immediately prior to installation. Reject damaged and defective items.
- 3.04 Provide attachment and connection devices and methods for securing work. Secure work true to line and level, and within recognized industry tolerances. Allow expansion and building movement. Provide uniform joint width in exposed work. Arrange joints in exposed work to obtain the best visual effect. Refer questionable visual-effect choices to the Owner for final decision.
- 3.05 Recheck measurements and dimensions of the work, as in integral step of starting each installation.
- 3.06 Install each unit-of-work during weather conditions and project status which will ensure the best possible results in coordination with the entire work. Isolate each unit of work from incompatible work as necessary to prevent deterioration.
- 3.07 Coordinate enclosure of the work with required inspections and tests, so as to minimize the necessity of uncovering work for that purpose.
- 3.08 Mounting Heights: Where mounting heights are not indicated, mount individual units of work at industry recognized standard mounting heights for the particular application indicated. Refer questionable mounting height choices to the Designer for final decision.
- 3.09 CLEANING AND PROTECTION OF EXISTING AND NEW WORK:
 - A. General: During handling and installation of work at the project site, clean and protect work in progress and adjoining work on the basis of continuous maintenance. Apply protective covering on installed work where it is required to ensure freedom from damage or deterioration at time of substantial completion.
 - B. Clean and perform maintenance on installed work as frequently as necessary through the remainder of the construction period. Adjust and lubricate operable components to ensure operability without damaging effects.
 - C. Limiting Exposures of Work: To the extent possible through reasonable control and protection methods, supervise performance of the work in such a manner and by such means which will ensure that none of the work, whether completed or in progress, will be subjected to harmful, dangerous or otherwise deleterious exposure during the construction period. Such exposures include, where applicable, but not by way of limitation the following:
 - 1. Excessive static or dynamic loading.
 - 2. Excessive internal or external pressures.
 - 3. Excessively high or low temperatures.
 - 4. Thermal shock.
 - 5. Excessively high or low humidity.
 - 6. Air contamination or pollution.
 - 7. Water or ice.
 - 8. Solvents.
 - 9. Chemicals.
 - 10. Light.
 - 11. Radiation.

12. Puncture.
13. Abrasion.
14. Heavy traffic.
15. Soiling.
16. Bacteria.
17. Insect infestation.
18. Combustion.
19. Electrical current.
20. High speed operation, improper lubrication, unusual wear or other misuse.
21. Incompatible interface.
22. Destructive testing.
23. Misalignment.
24. Excessive weathering.
25. Unprotected storage.
26. Improper shipping or handling.
27. Theft.
28. Vandalism.

END OF SECTION 01 41 00

DEFINITIONS AND STANDARDS

PART 1 - GENERAL

1.01 RELATED DOCUMENTS:

- A. Drawings, Notice to Bidders and Standard General Conditions of the Construction Contract, including Supplementary General Conditions and Division-1 Specification Sections, apply to work of this section.

1.02 DESCRIPTION OF REQUIREMENTS:

- A. General: This section specifies procedural and administrative requirements for compliance with governing regulations and codes and standards imposed upon the Work. These requirements include obtaining permits, licenses, inspections, releases and similar documentation, as well as payments, statements and similar requirements associated with regulations, codes and standards.

- 1. The term "Regulations" is defined to include laws, statutes, ordinances and lawful orders issued by governing authorities, as well as those rules, conventions and agreements within the construction industry which effectively control the performance of the Work regardless of whether they are lawfully imposed by governing authority or not.

- A. Governing Regulations: Refer to General and Supplementary Conditions for requirements related to compliance with governing regulations.

1.03 DEFINITIONS:

- A. Owner: Durham Technical Community College
- B. Designer or Engineer: The term "Designer" or "Engineer" refers to Sud Associates, P.A., 1813 Chapel Hill Road, Durham, NC 27707 and specifically the Design Engineer of Record as indicated by a Professional Engineering Seal affixed to the contract documents or duly appointed representative under the Engineer's responsible charge.
- C. Contractor: The corporation, company, partnership, or individual who has entered into contract for the performance of the work covered by the drawings and specifications and is liable for the payment of a legal debt pertaining to the work.
- D. General Explanation: Certain terms used in contract documents are defined in this article. Definitions and explanations contained in this section are not necessarily complete, but are general for the Work to the extent that they are not stated more explicitly in another element of the contract documents.
- E. General Requirements: Provisions and requirements of other Division-1 sections apply to the entire work of the Contract and, where so indicated, to other elements which are included in the project.
- F. Indicated: The term "indicated" is a cross-reference to graphic representations, notes or schedules on the drawings, to other paragraphs or schedules in the specifications, and to similar means of recording requirements in contract documents. Where terms such as "shown", "noted", "scheduled", and "specified" are used in lieu of "indicated", it is for the purpose of helping the reader locate the cross-reference, and no limitation of location is intended except as specifically noted.
- G. Directed, Requested, etc.: Terms such as "directed," "requested," "authorized," "selected," "approved," "required," "accepted," and "permitted" mean "directed by the Designer," "requested by the Designer," and similar phrases. However, no such implied meaning will be interpreted to extend the Engineer's responsibility into the Contractor's area of construction supervision.

- H. Approve: Where used in conjunction with the Engineer's response to submittals, requests, applications,

inquiries, reports and claims by the Contractor, the term "approved" will be held to limitations of the Engineer's responsibilities and duties as specified in General and Supplementary Conditions. In no case will the Engineer's approval be interpreted as a release of the Contractor from responsibilities to fulfill requirements of contract documents or acceptance of the Work, unless otherwise provided by requirements of the contract documents.

- I. "Work" or "Project": The work shown in the Drawings and specified herein.
- J. Project Site: The term "project site" means the space available to the Contractor for performance of the Work, either exclusively or in conjunction with others performing other construction as part of the project. The extent of the project site is shown on the drawings.
- K. "City": Durham, NC
- L. Furnish: The term "furnish" is used to mean "supply and deliver to the project site, ready for unloading, unpacking, assembly, installation, and similar operations."
- M. Install: The term "install" is used to describe operations at project site including the actual "unloading, unpacking, assembly, erection, placing, anchoring, applying, working to dimension, finishing, curing, protecting, cleaning and similar operations".
- N. Provide: The term "provide" means "to furnish and install, complete and ready for the intended use".
- O. Installer: The "installer" is "the entity" (person or firm) engaged by the Contractor, its subcontractor or sub-subcontractor for performance of a particular element of construction at the project site, including installation, erection, application and similar required operations. It is a requirement that installers are experienced in the operations they are engaged to perform.
- P. Testing Laboratories: A "testing laboratory" is an independent entity engaged to perform specific inspections or tests of the Work, either at the project site or elsewhere, and to report, and (if required) interpret results of those inspections or tests. A list of "Third Party Agencies Accredited by the NCBCC to Label Electrical & Mechanical Equipment as of January 1, 2016," is included at the end of this specification section for reference.

1.04 SPECIFICATION FORMAT AND CONTENT EXPLANATION:

- A. General: This article is provided to help the user of these specifications more readily understand the format, language, implied requirements and similar conventions of content. None of the following explanations shall be interpreted to modify the substance of contract requirements.
 - 1. Production Methods: Portions of these specifications have been produced by editing master specifications; they may contain minor deviations from traditional writing formats. Such deviations are a natural result of this production technique, and no other meaning shall be implied.
- B. Specification Format: These specifications are organized based upon the Construction Specifications Institute's format. The organization of these specifications into Divisions, Sections or Trade Headings conforms generally to recognized industry practice.
- C. Specification Content: This project specification has been produced employing certain conventions in the use of language as well as conventions regarding the intended meaning of certain terms, words, and phrases when used in particular situations or circumstances. These conventions are explained as follows:
 - 1. In certain circumstances, language used in specifications and other contract documents is of the abbreviated type. Implied words and meanings will be appropriately interpreted. Singular words will be interpreted as plural and plural words will be interpreted as singular where applicable and where the full context of the contract documents so indicates.

- D. Imperative Language is used generally in the specifications. Requirements expressed imperatively are to be

performed by the Contractor. At certain locations in the text, for clarity, contrasting subjective language is used to describe responsibilities which must be fulfilled indirectly by the Contractor, or by others when so noted.

- E. Methods of Specifying: Techniques or methods of specifying requirements vary throughout the text. The method used for specifying one element of the Work has no bearing on requirements for another element of the Work.
- F. Assignment of Specialists: In certain circumstances, the specification requires or implies that specific elements of the Work are to be assigned to specialists who must be engaged to perform that element of the Work. Such assignments are special requirements over which the Contractor has no choice or option. They are intended to establish which party or entity involved in a specific element of the Work is considered as being sufficiently experienced in the indicated construction processes or operations to be recognized as "expert" in those processes or operations. Nevertheless, the ultimate responsibility for fulfilling all contract requirements remains with the Contractor.
 - 1. These requirements should not be interpreted to conflict with the enforcement of building codes and similar regulations governing the Work. They are also not intended to interfere with local trade union jurisdictional settlements and similar conventions.
 - 2. Trades: The use of certain titles such as "carpentry" in the specification, is not intended to imply that the Work must be performed by accredited or unionized individuals of a corresponding generic name, such as "carpenter". It also is not intended to imply that the requirements specified apply exclusively to tradespersons of that corresponding generic name.

1.05 DRAWING SYMBOLS:

- A. General: Except as otherwise indicated, graphic symbols used on the drawings are those symbols recognized in the construction industry for purposes indicated.
- B. Mechanical/Electrical Drawings: Graphic symbols used on mechanical and electrical drawings are generally aligned with symbols recommended by ASHRAE. Where appropriate, these symbols are supplemented by more specific symbols as recommended by other technical associations including ASME, ASPE, IEEE and similar organizations. Refer instances of uncertainty to the Engineer for clarification before proceeding.

1.06 INDUSTRY STANDARDS:

- A. Applicability of Standards: Except where more explicit or stringent requirements are written into the contract documents, applicable construction industry standards have the same force and effect as if bound into or copied directly into the contract documents. Such industry standards are made a part of the contract documents by reference. Individual specification sections indicate which codes and standards the Contractor must keep available at the project site for reference.
 - 1. Referenced standards (standards referenced directly in the contract documents) take precedence over standards that are not referenced but generally recognized in the industry for applicability to the Work.
 - 2. Unreferenced Standards: Except as otherwise limited by the contract documents, standards not referenced but recognized in the construction industry as having direct applicability will be enforced for performance of the Work. The decision as to whether an industry code or standard is applicable, or as to which of several standards are applicable, is the sole responsibility of the Designer.
- B. Publication Dates: Except as otherwise indicated, where compliance with an industry standard is required, comply with standard in effect as of date of contract documents.
 - 1. Updated Standards: At the request of the Designer, Contractor or governing authority, submit a change order proposal where an applicable industry code or standard has been revised and reissued after the date of the contract documents and before the performance of the Work affected. The Designer will decide whether to issue a change order to proceed with the updated standard.

- C. Conflicting Requirements: Where compliance with two or more standards is specified, and where these

standards establish different or conflicting requirements for minimum quantities or quality levels, the most stringent requirement will be enforced, unless the contract documents specifically indicate otherwise. Refer requirements that are different, but apparently equal, and uncertainties as to which quality level is more stringent to the Designer for a decision before proceeding.

1. Minimum Quantities or Quality Levels: In every instance the quantity or quality level shown or specified is intended to be the minimum to be provided or performed. Unless otherwise indicated, the actual Work may either comply exactly, within specified tolerances, with the minimum quantity or quality specified, or may exceed that minimum within reasonable limits. In complying with these requirements, the indicated numeric values are minimum or maximum values, as noted, or as appropriate for the context of the requirements. Refer instances of uncertainty to the Designer for decision before proceeding.
- D. Copies of Standards: The contract documents require that each entity performing work be experienced in that part of the Work being performed. Each entity is also required to be familiar with industry standards applicable to that part of the Work. Copies of applicable standards are not bound with the contract documents.
1. Where copies of standards are needed for proper performance of the Work, the Contractor is required to obtain such copies directly from the publication source.
 2. Although copies of standards needed for enforcement of requirements may be required submittals, the Designer reserves the right to require the Contractor to submit additional copies as necessary for enforcement of requirements.
- E. Abbreviations and Names: Trade association names and titles of general standards are frequently abbreviated. Where acronyms or abbreviations are used in the specifications or other contract documents they are defined to mean the recognized name of the trade association, standards generating organization, governing authority or other entity applicable to the context of the text provision. Refer to the "Encyclopedia of Associations", published by Gale Research Co., available in most libraries.
- F. Federal Government Agencies: Names and titles of federal government standard or specification producing agencies are frequently abbreviated. The following acronyms or abbreviations as referenced in the contract documents indicate names of standard or specification producing agencies of the federal government. Names and addresses are subject to change but are believed to be, but are not assured to be, accurate and up-to-date as of the date of the contract documents.

CFR Code of Federal Regulations
Available from the Government Printing Office
North Capitol Street
between G and H Streets NW
Washington, DC 20402 (202) 783-3238
(Material is usually first published in the Federal Register)

CPSC Consumer Product Safety Commission
1111 Eighteenth Street NW
Washington, DC 20207 (202) 634-7700

CS Commercial Standard (U.S. Department of Commerce)
Government Printing Office
Washington, DC 20402 (202) 377-2000

DOT Department of Transportation
400 Seventh Street SW
Washington, DC 20590 (202) 426-4000

EPA Environmental Protection Agency
401 M Street SW
Washington, DC 20460 (202) 829-3535

- FCC Federal Communications Commission
1919 M Street NW
Washington, DC 20554 (202) 632-7000

- FS Federal Specification
(General Services Administration)
Specifications Unit (WFSIS)
7th and D Streets SW
Washington, DC 20406 (202) 472-2205 or 472-2140

- MIL Military Standardization Documents
(U.S. Department of Defense)
Naval Publications and Forms Center
5801 Tabor Avenue
Philadelphia, PA 19120

- NBS National Bureau of Standards
(U.S. Department of Commerce)
Gaithersburg, MD 20234 (301) 921-1000

- OSHA Occupational Safety and Health Administration
(U.S. Department of Labor)
Government Printing Office
Washington, DC 20402 (202) 783-3238

- PS Product Standard of NBS
(U.S. Department of Commerce)
Government Printing Office
Washington, DC 20402 (202) 783-3238

- USPS U.S. Postal Service
475 L'Enfant Plaza SW
Washington, DC 20260 (202) 245-4000

1.07 SUBMITTALS:

- A. Permits, Licenses, and Certificates: For the Owner's records, submit copies of permits, licenses, certifications, inspection reports, releases, jurisdictional settlements, notices, receipts for fee payments, judgments, and similar documents, correspondence and records established in conjunction with compliance with standards and regulations bearing upon performance of the Work.

PART 2 - PRODUCTS (Not Applicable)

PART 3 - EXECUTION (Not Applicable)

END OF SECTION 01 42 16

**THIRD PARTY AGENCIES ACCREDITED BY THE NCBC TO
LABEL ELECTRICAL & MECHANICAL EQUIPMENT AS OF JANUARY 1, 2016**

Applied Research Laboratories

5371 Northwest 161st Street, Miami, Florida 33014
(305) 624-4800

Equipment Categories

6, 8, 12, 14, 15, 18, 21, 22, 24, 31, & 43

CSA International

178 Rexdale Boulevard, Toronto, Ontario, Canada M9W 1R3
(416) 747-2798

Equipment Categories

All

Communication Certification Laboratory NEMKO-CCL, Inc.

1940 Alexander Street, Salt Lake City, UT 84119
801-972-6146

Equipment Categories

7, 10, 11, 26, 27, & 28

Curtis-Straus

527 Great Road, Littleton, Massachusetts 01460
(978) 486-8880 x 296

Equipment Categories

7, & 26-28

FM Approvals LLC

PO Box 9102, Norwood, Massachusetts 02062
(781) 762-4300

Equipment Categories

4, 5, 9, 13, 17, 19, 24, 28, 31, 32, 39, 43, & 47-51

IAPMO EGS

5001 East Philadelphia Drive, Ontario, California 91761
(909) 472-4100

Equipment Categories

12, & 30

Intertek Testing Services ITS-ETL

3933 US Route 11, Cortland, New York 13045-2014
(607) 753-6711

Equipment Categories

All except 21

Intertek Testing Services ITS-Warnock

3933 US Route 11, Cortland, New York 13045-2014
(607) 753-6711

Equipment Categories

17, 18, 21, 24, & 25

MET Laboratories

2200 Gateway Centre Blvd., Suite 215, Morrisville, NC 27560
(919) 481-9319

Equipment Categories

7, 10 - 16, 18, 22, 23, 26 - 31, 37 - 40, 43, 44, 47, 48, & 50

National Technical Systems (NTS)

533 Main Street, Acton, MA 01720
(978) 263-2933

Equipment Categories

26, 27, & 28

NSF International

789 North Dixboro Road, Ann Arbor, Michigan 48105-9723
(734) 769-8010

Equipment Categories

11-16, 26-31, 40, 43, & 48

Omni-Test Laboratories

13327 NE Airport Way, Portland, Oregon 97230
(503) 643-3788

Equipment Categories

17, 18, & 21

PFS Corporation

1507 Matt Pass, Cottage Grove, Wisconsin 53527
(608) 839-1013

Equipment Categories

17, 19, 20, 21, & Replacement Blowers & coils

QPS Evaluation Services, Inc.

81 Kelfield Street, Unit 8, Toronto, Ontario, Canada M9W 5A3
(416) 241-8857 x 422

Equipment Categories

6-12, 14-16, 22, 23, 26-29, 31, 36, 39, 40, 43, 46-48, 50, & 51

RADCO

3220 East 59th Street, Long Beach, California 90805
(310) 272-7231

Equipment Categories

17, 18, & Replacement blowers & coils

Salus Engineering International

3004 Scott Boulevard, Santa Clara, California 95054
(408) 235-8831

Equipment Categories

16, 28, 37, 43, & 50

SGS Consumer Testing Services

620 Old Peachtree Road, Suite 100, Suwanee, GA 30024
(770) 570-1800

Equipment Categories

1-5, 9-16, 22, 26-31, 33, 35-41, 43, 47-48, & 50-51

TUV SUD America

10 Centennial Drive, Peabody, MA 01960
(978) 573-2530

Equipment Categories

4-8, 10-20, 22, 23, 26-29, 31, 35, 36, 38, 39, 43, 46-48, & 50

TUV Rheinland of North America

762 Park Avenue, Youngsville, North Carolina 27596
(919) 554-3668

Equipment Categories

7-9, 11-14, 16, 26-28, 31, 40, 43, 47, & 48

Underwriters Laboratories, Inc.

12 Laboratory Drive, RTP, North Carolina 27709
(919) 549-1400

Equipment Categories

All

EQUIPMENT CATEGORIES

1. Conductors for General Wiring
2. Flexible Cords
3. Wires and Cables for Special Applications
4. Materials and Components for Special Applications
5. Alarm Signal and Detecting System Components
6. CATV and Radio Distribution System Components
7. Communication System Components
8. Radio and Television Components
9. Energy Management System Components and Controllers
10. Sound Recording and Reproduction Equipment
11. Fixed Office Appliances and Business Equipment
12. Electrical Appliances
13. Electric Space Heating Equipment and Accessories
14. Air Conditioning Equipment and Accessories
15. Heat Pump Equipment and Accessories
16. Refrigeration Equipment and Accessories
17. Gas Fired Heating Equipment and Accessories
18. Gas Fired Appliances
19. Oil Fired Heating Equipment and Accessories
20. Oil Fired Appliances
21. Solid Fuel Heating Equipment
22. Fans and Ventilators
23. Filtering Equipment
24. Duct Materials Including Dampers
25. Chimneys and Vents
26. Electrical Data Processing Equipment
27. Medical, Dental, and X-Ray Equipment
28. Laboratory Equipment, Electrical Measuring, and Testing Equipment
29. Food Preparation Machines
30. Swimming Pool and Spa Equipment
31. Miscellaneous Fixed Equipment - Amusement Machines, Animal Care, Appliances
Battery Chargers, Cleaning Machines, etc.
32. Fire Extinguishing Equipment
33. Circuit Breakers
34. Fuses
35. Wiring Devices, Attachment Plugs and Toggle Switches
36. Switches and Switching Devices - Other than Toggle
37. Panelboards
38. Switchboards
39. Transformers
40. Electrical Signs and Accessories
41. Ground-Fault Circuit Interrupters
42. Ground-Fault Sensing and Relaying Equipment
43. Industrial Control Equipment - Motor Controllers, Industrial Control Panels,
Motor Control Centers, Motorized Valves, Solenoids, etc.
44. Transient Voltage Surge Suppressors and Filters
45. Lightning Protection System Components and Lightning Protection Devices
46. Metering Enclosures and Meter Sockets
47. Emergency Lighting and Power Equipment System Components
48. Lighting Fixtures, Lamp Holders, and Accessories
49. Auxiliary Gutters, Junction, Pull and Outlet Boxes, and Cabinets and Cutout Boxes
50. Electrical Equipment for Hazardous Locations
51. Grounding and Bonding Equipment
52. Wire Connectors, Lugs, and Terminal Fittings
53. Insulating Tape and Closures

SHOP DRAWINGS, PRODUCT DATA AND SAMPLES

PART 1 - GENERAL

1.01 RELATED DOCUMENTS:

- A. Drawings, Notice to Bidders and Standard General Conditions of the Construction Contract, including Supplementary General Conditions and Division-1 Specification sections, apply to work of this section.

1.02 DESCRIPTION OF REQUIREMENTS:

- A. General: This section specifies procedural requirements for non-administrative submittals including shop drawings, product data, samples and other miscellaneous work-related submittals. Shop drawings, product data, samples and other work-related submittals are required to amplify, expand and coordinate the information contained in the Contract Documents.
 - 1. ALL SUBMITTALS SHALL BE ACCOMPANIED BY THE MANUFACTURER'S MODEL NUMBER, PRODUCT DESCRIPTION, PARTS LIST, OPERATING INSTRUCTIONS, MAINTENANCE INSTRUCTIONS, DIAGNOSTIC AND TROUBLE SHOOTING DATA AND COMPLETE REPAIR MANUAL. SUBMITTALS WILL NOT BE PROCESSED UNTIL ALL THIS DATA IS RECEIVED AND APPROVED BY THE DESIGNER.
 - 2. Refer to other Division-1 sections and other contract documents for specifications on administrative, non-work related submittals. Such submittals include, but are not limited to the following items:
 - a) Permits.
 - b) Payment applications.
 - c) Performance and payment bonds.
 - d) Insurance certificates.
 - e) Inspection and test reports.
 - f) Schedule of values.
 - g) Progress reports.
 - h) Listing of subcontractors.
- B. Shop drawings are technical drawings and data that have been specially prepared for this project, including but not limited to the following items:
 - 1. Fabrication and installation drawings.
 - 2. Setting diagrams.
 - 3. Shopwork manufacturing instructions.
 - 4. Templates.
 - 5. Patterns.
 - 6. Coordination drawings (for use on-site).
 - 7. Schedules.
 - 8. Design mix formulas.
 - 9. Contractor's engineering calculations.
 - 10. Standard information prepared without specific reference to a project is not considered to be shop drawings.
- C. Product data includes standard printed information on manufactured products that has not been specially-prepared for this project, including but not limited to the following items:
 - 1. Manufacturer's product specifications and installation Instructions.
 - 2. Standard color charts.
 - 3. Catalog cuts.

4. Roughing-in diagram and templates.
5. Standard wiring diagrams.
6. Printed performance curves.
7. Operational range diagrams.
8. Mill reports.
9. Standard product operating and maintenance manuals.

D. Samples are physical examples of work, including but not limited to the following items:

1. Partial sections of manufactured or fabricated work.
2. Small cuts or containers of materials.
3. Complete units of repetitively-used materials.
4. Swatches showing color, texture and pattern.
5. Color range sets.
6. Units of work to be used for independent inspection and testing.

E. Miscellaneous submittals are work-related, non-administrative submittals that do not fit in the three previous categories, including, but not limited to the following:

1. Specially-prepared and standard printed warranties.
2. Maintenance agreements.
3. Workmanship bonds.
4. Survey data and reports.
5. Project photographs.
6. Testing and certification reports.
7. Record drawings.
8. Field measurement data.
9. Operating and maintenance manuals.
10. Keys and other security protection devices.
11. Maintenance tools and spare parts.
12. Overrun stock.

1.3 SUBMITTAL PROCEDURES:

A. General: Refer to the General Conditions for basic procedures for submittal handling:

B. Coordination: Coordinate the preparation and processing of submittals with the performance of the work. Coordinate each separate submittal with other submittals and related activities such as testing, purchasing, fabrication, delivery and similar activities that require sequential activity.

1. Coordinate the submittal of different units of interrelated work so that one submittal will not be delayed by the Designer's need to review a related submittal. The Designer reserves the right to withhold action on any submittal requiring coordination with other submittals until related submittals are forthcoming.

C. Coordination of Submittal Times: Prepare and transmit each submittal to the Designer sufficiently in advance of the scheduled performance of related work and other applicable activities. Transmit different kinds of submittals for the same unit of work so that processing will not be delayed by the Designer's need to review submittals concurrently for coordination.

1. Review Time: Allow sufficient time so that the installation will not be delayed as a result of the time required to properly process submittals, including time for resubmittal, if necessary. Advise the Designer on each submittal, as to whether processing time is critical to the progress of the work, and if the work would be expedited if processing time could be shortened.

- a) Allow two weeks for the Designer's initial processing of each submittal. Allow a longer time period where processing must be delayed for coordination with subsequent submittals. The Designer will advise the Contractor promptly when it is determined that a submittal being processed must be

- delayed for coordination.
- b) Allow one week for reprocessing each submittal.
- c) No extension of time will be authorized because of the Contractor's failure to transmit submittals to the Designer sufficiently in advance of the work.

D. Submittal Preparation: Mark each submittal with a permanent label for identification. Provide the following information on the label for proper processing and recording of action taken.

1. Project name.
2. Date.
3. Name and address of Designer.
4. Name and address of Contractor.
5. Name and address of subcontractor.
6. Name and address of supplier.
7. Name of manufacturer.
8. Number and title of appropriate specification section.
9. Drawing number and detail references, as appropriate.
10. Similar definitive information as necessary.

Provide a space on the label for the Contractor's review and approval markings, and a space for the Designer's "Action" marking.

E. Submittal Transmittal: Package each submittal appropriately for transmittal and handling. Transmit each submittal from the Contractor to the Designer, and to other destinations as indicated, by use of a transmittal form. Submittals received from sources other than the Contractor will be returned to the sender "without action."

F. Transmittal Form: Prepare a draft of a transmittal form and submit it to the Designer for acceptance. Provide the form places for the following information.

1. Project name.
2. Date.
3. To:
4. From:
5. Names of subcontractor, manufacturer, and supplier.
6. References.
7. Category and type of submittal.
8. Submittal purpose and description.
9. Submittal and transmittal distribution record.
10. Signature of transmitter.
11. Contractor's certification stating that the information submitted complies with the requirements of the Contract Documents, with a place for the Contractor's signature.

Record relevant information and requests for data on the transmittal form. On the transmittal form, or on a separate sheet attached to the form, record deviations from the requirements of the Contract Documents, if any, including minor variations and limitations.

1.04 SPECIFIC SUBMITTAL REQUIREMENTS:

A. General: Specific submittal requirements for individual units of work are specified in the applicable specification section. Except as otherwise indicated in the individual specification sections, comply with the requirements specified herein for each type of submittal.

Where it is necessary to provide intermediate submittals between the initial and final submittals, provide and process intermediate submittals in the same manner as for initial submittals.

B. Shop Drawings: Information required on shop drawings includes dimensions, identification of specific Town of Carrboro Project # 20-2023 Shop Drawings, Product Data and Samples Century Center Chiller Replacement and DDC Controls Upgrade 01 65 00 - 3

products and materials which are included in the work, compliance with specified standards and notations of coordination requirements with other work. Provide special notation of dimensions that have been established by field measurement. Highlight, encircle or otherwise indicate deviations from the contract documents on the shop drawings.

1. Coordination Drawings: Provide coordination drawings where required for the integration of the work, including work first shown in detail on shop drawings or product data. Show sequencing and relationship of separate units of work which must interface in a restricted manner to fit in the space provided, or function as indicated. Coordination drawings are considered shop drawings and must be definitive in nature.
 2. Do not permit shop drawing copies without an appropriate final "Action" marking by the Designer to be used in connection with the work.
- C. Preparation: Submit newly prepared information, drawn to accurate scale on sheets not less than 8-1/2" x 11"; except for actual pattern or template type drawings, the maximum sheet size shall not exceed 24" x 36". Indicate the name of the firm that prepared each shop drawing and provide appropriate project identification in the title block. Provide a space not less than 20 sq. in. beside the title block for marking the record of the review process and the Designer's "Action" marking.
1. Do not reproduce contract documents or copy standard printed information as the basis of shop drawings. Shop drawings which are submitted to the Designer without Contractor's signed and dated "Approval" stamp permanently affixed will be returned without action.
- D. Final Submittal: Submittals of shop drawings and manufacturer's data, etc. shall be provided to the Designer electronically in PDF format. The Designer will review the submittals and return them electronically. The exception would be color samples or other material that cannot be adequately represented electronically, and these should be submitted as five (5) hard copies. The Designer will review them and return three (3) copies.
- E. Product Data: General information required specifically as product data includes manufacturers standard printed recommendations for application and use, compliance with recognized standards of trade associations and testing agencies, and the application of their labels and seals (if any), special notation of dimensions which have been verified by way of field measurement, and special coordination requirements for interfacing the material, product or system with other work.
- F. Preparation: Collect required product data into a single submittal for each unit of work or system. Mark each copy to show which choices and options are applicable to the project. Where product data has been printed to include information on several similar products, some of which are not required for use on the project, or are not included in this submittal, mark the copies to show clearly that such information is not applicable.
1. Where product data must be specially prepared for required products, materials or systems, because standard printed data is not suitable for use, submit data as "shop drawings" and not as "product data".
- G. Submittals: Product data submittal is required for information and record and to determine that the products, materials and systems comply with the provisions of the contract documents. Therefore, the initial submittal is also the final submittal, except where the Designer observes that there is non-compliance with the provisions of the contract documents and returns the submittal promptly to the Contractor marked with the appropriate "Action".
- H. Provide a preliminary single-copy submittal where required, for selection of options by the Designer.
1. Initial Submittal: Except as otherwise indicated in individual sections of these specifications, electronically submit each required product data submittal. The Designer will return the submittal electronically marked with "Action" and corrections or modifications as required.
 2. Do not submit product data or allow its use on the project, until compliance with the requirements of the contract documents has been confirmed by the Contractor.

3. Final Distribution: Furnish copies of product data to subcontractors, suppliers, fabricators, manufacturers, installers, governing authorities and others as required for proper performance of the work. Show distribution on transmittal forms.
 4. Installation Copy: Do not proceed with installation of materials, products and systems until a copy of product data applicable to the installation is in the possession of the installer. Do not permit the use of unmarked copies of product data in connection with the performance of the work.
- I. Samples: Submit samples for the Designer's visual review of general generic kind, color, pattern, and texture, and for a final check of the coordination of these characteristics with other related elements of the work. Samples are also submitted for quality control comparison of these characteristics between the final samples submittal and the actual work as it is delivered and installed.
1. Refer to individual work sections of these specifications for additional sample requirements, which may be intended for examination or testing of additional characteristics. Compliance with other required characteristics is the exclusive responsibility of the Contractor; such compliance is not considered in the Designer's review and "Action" indication on sample submittals.
 2. Documentation required specifically for sample submittals includes a generic description of the sample, the sample source or the product name or manufacturer, compliance with governing regulations and recognized standards. In addition, indicate limitations in terms of availability, sizes, delivery time, and similar limiting characteristics.
- J. Preparation: Where possible provide samples that are physically identical with the proposed material or product to be incorporated in the work; provide full scale, fully fabricated samples cured and finished in the manner specified. Where variations in color, pattern, or texture are inherent in the material or product represented by the sample, submit multiple units of the sample (not less than 3 units), which show the approximate limits of variations. Where samples are specified for the Designer's selection of color, texture or pattern, submit a full set of available choices for the material or product. Mount, display, or package samples in the manner specified to facilitate the review of indicated qualities. Prepare samples to match the Designer's sample where so indicated.
- K. Submittal: At the Contractor's option and depending upon the nature of the anticipated response from the Designer, the initial submittal of samples may be either a preliminary submittal or a final submittal.
1. Preliminary submittal, of a single set of samples, is required where requirements indicate the Designer's selection of color, pattern, texture, or similar characteristics from a manufacturer's range of standard choices is necessary. Preliminary submittals will be reviewed and returned with the Designer's "Action" marking.
 2. Final Submittals: Submit two (2) sets of samples in the final submittal, one set will be returned.
 3. Distribution of Samples: Maintain the final submittal sets of samples, as returned by the Designer, at the project site, available for quality control comparisons throughout the course of performing the work. In addition, final submittal sets may be used to obtain final acceptance of the work associated with each set. Prepare and distribute additional sets of samples to subcontractors, suppliers, fabricators, manufacturers, installers, governing authorities, and others as required for proper performance of the work. Show final distribution on transmittal forms.
- L. Miscellaneous Submittals:
1. Inspection and Test Reports: Classify each inspection and test report as being either "shop drawings" or "product data" depending on whether the report is specially prepared for the project, or a standard publication of workmanship control testing at the point of production. Process inspection and test reports accordingly.
 2. Warranties: Refer to section "Products and Substitutions" for specific general requirements on warranties, product bonds, workmanship bonds and maintenance agreements. In addition to copies desired for the Contractor's use, furnish 2 executed copies of such warranties, bonds or agreements. Provide 2 additional copies where required for maintenance manuals.
 3. Standards: Where submittal of a copy of standards is indicated, and except where copies of standards are

specified as an integral part of a "Product Data" submittal, submit a single copy of standards for Designer's use. Where workmanship, whether at the project site or elsewhere is governed by a standard, furnish additional copies of the standard to fabricators, installers and others involved in the performance of the work.

4. Closeout Submittals: Refer to individual sections of these specifications for specific submittal requirements of project closeout information, materials, tools, and similar items.
5. Record Documents: Furnish set of original documents as maintained on the project site. Along with original marked-up record drawings provide 2 photographic copies of marked-up drawings.
6. Operating Maintenance, Repair and Diagnostic Manuals: Furnish 4 sets.
7. Materials and Tools: Refer to individual sections of these specifications for required quantities of spare parts, extra and overrun stock, maintenance tools and devices, keys, and similar physical units to be submitted.

M. General Distribution: Provide additional distribution of submittals to subcontractors, suppliers, fabricators, installers, governing authorities, and others as necessary for the proper performance of the work. Include such additional copies of submittals in the transmittal to the Designer where the submittals are required to receive "Action" marking before final distribution. Record distributions on transmittal forms.

1.05 DESIGNER'S ACTION:

A. General: Except for submittals for the record and similar purposes, where action and return on submittals is required or requested, the Designer will review each submittal, mark with appropriate "Action", and where possible return within 2 weeks of receipt. Where the submittal must be held for coordination, the Designer will advise the Contractor without delay.

1. Action Stamp: Submittals returned to the Contractor with the Engineer's "REVIEWED" or "REVIEWED WITH NOTATIONS" stamp need not be resubmitted for approval; however, any notes or corrections indicated by the Engineer on the "REVIEWED WITH NOTATIONS" submittals shall be complied with in the selection, fabrication, and installation. Two hard copies or one pdf copy of corrected shop drawings marked "REVIEWED WITH NOTATIONS" shall be submitted to the Engineer for record.
2. If submittals are stamped for resubmittal, corrections shall be made on the original submittals; and the new submittals shall be submitted for review.
3. Review of samples, cuts and shop drawings, and matter submitted for approval, shall not be construed as relieving the Contractor of compliance with the Specifications, even if such approval is made in writing, unless the attention of the Engineer is called to the noncomplying features by letter accompanying the submitted matter.

PART 2 - PRODUCTS (Not Applicable)

PART 3 - EXECUTION (Not Applicable)

END OF SECTION 01 65 00

PRODUCTS AND SUBSTITUTIONS

PART 1 - GENERAL

1.01 RELATED DOCUMENTS:

- A. Drawings, Notice to Bidders and Standard General Conditions of the Construction Contract, including Supplementary General Conditions and Division-1 Specification sections, apply to work of this section.

1.02 DESCRIPTION OF REQUIREMENTS:

- A. Definitions: Definitions used in this paragraph are not intended to negate the meaning of other terms used in the contract documents, including such terms as, "specialties," "systems," "structure," "finishes," "accessories," "furnishings," "special construction" and similar terms. Such terms are self-explanatory and have recognized meanings in the construction industry.
 - 1. "Products" are items purchased for incorporation in the Work, regardless of whether they were specifically purchased for the project or taken from the Contractor's previously purchased stock. The term "product" as used herein includes the terms "material," "equipment," "system" and other terms of similar intent.
 - 2. "Named Products" are products identified by use of the manufacturer's name for a product, including such items as a make or model designation, as recorded in published product literature, of the latest issue as of the date of the contract documents.
 - 3. "Materials" are products that must be substantially cut, shaped, worked, mixed, finished, refined or otherwise fabricated, processed, or installed to form units of work.
 - 4. "Equipment" is defined as a product with operational parts, regardless of whether motorized or manually operated, and in particular, a product that requires service connections such as wiring or piping.
- B. Substitutions: The Contractor's requests for changes in the products, materials, equipment and methods of construction required by the contract documents are considered requests for "substitutions," and are subject to the requirements specified herein. The following are not considered as substitutions:
 - 1. Revisions to the contract documents, where requested by the Owner or Engineer, are considered as "changes" not substitutions.
 - 2. Substitutions requested during the bidding period, which have been accepted prior to the Contract Date, are included in the contract documents and are not subject to the requirements for substitutions as specified herein.
 - 3. Specified Contractor options on products and construction methods included in the contract documents are choices available to the Contractor and are not subject to the requirements for substitutions as specified herein.
 - 4. Except as otherwise provided in the contract documents, the Contractor's determination of and compliance with governing regulations and orders as issued by governing authorities do not constitute "substitutions" and do not constitute a basis for change orders.
- C. Standards: Refer to Division-1 section "Definitions and Standards" for the applicability of industry standards to the products specified for the project, and for the acronyms used in the text of the specification sections.

1.03 QUALITY ASSURANCE:

- A. Source Limitations: To the fullest extent possible, provide products of the same generic kind, from a single source, for each unit of work.
- B. Compatibility of Options: Compatibility of products is a basic requirement of product selection. When the Contractor is given the option of selecting between two or more products for use on the project, the product

selected must be compatible with other products previously selected, even if the products previously selected were also Contractor options. The complete compatibility between the various choices available to the Contractor is not assured by the various requirements of the Contract documents but must be provided by the Contractor.

1.04 SUBMITTALS:

A. Product Listing Submittal:

B. General: Prepare a product-listing schedule in a form acceptable to the Designer. Show names of the principal products required for the work, by generic name. Show proprietary product names and the name of the manufacturer for each item listed that is to be purchased and incorporated into the Work.

C. Form: Prepare the product-listing schedule with information on each item tabulated under the following scheduled column headings:

1. Generic name as used in contract documents.
2. Proprietary name, model number and similar product designation.
3. Manufacturer's and supplier's name and city-state addresses.
4. Related unit-of-work specification section number.
5. Installer's name and primary trade of workmen.
6. Projected delivery date, or time span of delivery period.

D. Submittal: Submit three (3) copies of the product-listing schedule within 20 days after the date of award of contract. Provide a written explanation for omissions of data, and for known variations from contract requirements.

1. Designer's Action: The Designer will respond to the Contractor in writing within two (2) weeks of receipt of the product-listing schedule. No response by the Designer within the 2-week time period constitutes no objection to the listed products or manufacturers but does not constitute a waiver of the requirement that products comply with the requirements of the contract documents. The Designer's response will include the following:

- a) The Designer's listing of unacceptable product selections, if any, contains an explanation of the reasons for this action.
- b) A request for additional data necessary for the review and possible acceptance of the products and manufacturers listed.

E. Substitution Request Submittal:

1. Product Substitutions:

a) Products are generally specified by ASTM or other reference standards and/or by manufacturer's name and model number or trade name. When several products or manufacturers are specified as being equally acceptable, the Contractor has the option of using any product and manufacturer combination listed. **However, the contractor shall be aware that the cited examples are used only to denote the quality standard of product desired and that they do not restrict bidders to a specified brand, make, manufacturer or specific name; that they are used only to set forth and convey to bidders the general style, type, character and quality of product desired; and that equivalent products will be acceptable. Substitution of materials, items or equipment of equal or equivalent design shall be submitted to the architect or engineer for approval or disapproval; SUCH APPROVAL OR DISAPPROVAL SHALL BE MADE BY THE ARCHITECT OR ENGINEER 10 DAYS PRIOR TO THE OPENING OF BIDS.**

2. Requests for Substitutions: Submit all requests for substitutions at least 10 days prior to the opening of bids. Submit 3 copies of each request for substitution. In each request identify the product or fabrication or installation method to be replaced by the substitution; include related specification section and drawing

numbers, and complete documentation showing compliance with the requirements for substitutions. Include the following information, as appropriate, with each request.

- a) Provide complete product data, drawings and descriptions of products, and fabrication and installation procedures.
 - b) Provide samples where applicable or requested.
 - c) Provide a detailed comparison of the significant qualities of the proposed substitution with those of the work originally specified. Significant qualities include elements such as size, weight, durability, performance and visual effects where applicable.
 - d) Provide complete coordination information. Include all changes required in other elements of the work to accommodate the substitution, including work performed by the Owner and separate Contractors.
 - e) Provide a statement indicating the effect the substitution will have on the work schedule in comparison to the schedule without approval of the proposed substitution. Include information regarding the effect of the proposed substitution on the Contract Time.
 - f) Provide certification by the Contractor to the effect that, in the Contractor's opinion, after thorough evaluation, the proposed substitution will result in work that in every significant respect is equal-to or better than the work required by the Contract documents, and that it will perform adequately in the application indicated.
 - g) Included in this certification, the Contractor's waiver of rights to additional payment or time, which may subsequently be necessary because of the failure of the substitution to perform adequately.
3. Designer's Action: Within one week of receipt of the Contractor's request for substitution, the Designer will request additional information or documentation as may be needed for evaluation of the request. Within 2 weeks of receipt of the request, or within one week of receipt of the requested additional information or documentation, whichever is later, the Designer will notify the Contractor of either the acceptance or rejection of the proposed substitution.
- a) Rejection will include a statement giving reasons for the rejection.

1.05 PRODUCT DELIVERY, STORAGE, AND HANDLING:

- A. General: Deliver, store, and handle products in accordance with manufacturer's recommendations, using means and methods that will prevent damage, deterioration and loss, including theft. Control delivery schedules to minimize long-term storage at the site and to prevent overcrowding of construction spaces. In particular, coordinate delivery and installation to ensure minimum holding or storage times for items known or recognized to be flammable, hazardous, easily damaged, or sensitive to deterioration, theft and other sources of loss.
1. Deliver products to the premises in the manufacturer's sealed container or other packaging system, complete with labels and instructions for handling, storage, unpacking, protecting and installing. Owner's personnel will not accept delivered materials - arrangements must be made by Contractor concerned to have Contractor's own personnel accept all deliveries of construction materials.
 2. Store products at the site in a manner that will facilitate inspection and measurement of quantity or counting of units.
 3. Store heavy materials away from the project structure in a manner that will not endanger the supporting construction.

PART 2 - PRODUCTS

2.01 GENERAL PRODUCT COMPLIANCE:

- A. General: Requirements for individual products are indicated in the contract documents; compliance with these requirements is in itself a contract requirement. These requirements may be specified in any one of several different specifying methods, or in any combination of these methods. These methods include the following:

1. Proprietary.
2. Descriptive.
3. Performance.
4. Compliance with Reference Standards.

Compliance with codes, compliance with graphic details, allowances, and similar provisions of the contract documents also have a bearing on the selection process.

- B. Procedures for Selecting Products: The Contractor's options in selecting products are limited by the requirements of the contract documents and governing regulations. They are not controlled by industry traditions or procedures experienced by the Contractor on previous construction projects. Required procedures include but are not limited to the following for the various indicated methods of specifying:
1. Proprietary and Semi proprietary Specification Requirements:
 - a) Three or More Product Names: Where three or more products or manufacturers are named, provide one of the products named, at the Contractor's option. Exclude products that do not comply with specification requirements. In accordance with the Supplementary General Conditions submit all requests for substitutions prior to the opening of bids. Do not provide or offer to provide an unnamed product that was not approved prior to the opening of bids. Advise the Designer before proceeding where none of the named products comply with specification requirements or are feasible for use.
- C. Where products or manufacturers are specified by name, accompanied by the term "or-equal" or similar language, comply with the contract document provisions concerning "substitutions" to obtain approval from the Designer prior to the opening of bids for the use of an unnamed product.
1. Non-Proprietary Specification Requirements: Where the specifications name products or manufacturers that are available and may be incorporated in the Work, but do not restrict the Contractor to the use of these products only, the Contractor may, at his option, use any available product that complies with contract requirements.
 2. Descriptive Specification Requirements: Where the specifications describe a product or assembly generically, in detail, listing the exact characteristics required, but without use of a brand or trade name, provide products or assemblies that provide the characteristics indicated and otherwise comply with contract requirements.
 3. Performance Specification Requirements: Where the specifications require compliance with indicated performance requirements, provide products that comply with the specific performance requirements indicated, and that are recommended by the manufacturer for the application indicated. The manufacturer's recommendations may be contained in published product literature, or by the manufacturer's individual certification of performance. General overall performance of a product is implied where the product is specified for specific performances.
 4. Compliance with Standards, Codes and Regulations: Where the specifications require only compliance with an imposed standard, code or regulation, the Contractor has the option of selecting a product that complies with specification requirements, including the standards, codes and regulations. The burden of proof-of-compliance is on the Contractor.
 5. Visual Matching: Where matching an established sample is required, the final judgment of whether a product proposed by the Contractor matches the sample satisfactorily will be determined by the Designer. Where there is no product available within the specified product category that matches the sample satisfactorily and also complies with other specified requirements, comply with the provisions of the contract documents concerning "substitutions" and "change orders" for the selection of a matching product in another product category, or for non-compliance with specified requirements.
 6. Visual Selection: Except as otherwise indicated, where specified product requirements include the phrase "...as selected from the manufacturer's standard colors, patterns, textures..." or similar phrases, the Contractor has the option of selecting the product and manufacturer, provided the selection complies with other specified requirements. The Designer is subsequently responsible for selecting the color, pattern and texture from the product line selected by the Contractor.

- D. **Producer's Statement of Applicability:** Where individual specification sections indicate products that require a "Statement of Applicability" from the manufacturer or other producer, submit a written-certified statement from the producer stating that the producer has reviewed the proposed application of the product on the project. This statement shall state that the producer agrees with or does not object to the Designer's specification and the Contractor's selection of the product for use in the Work. The statement shall also state that the proposed application of the product on the project is suitable and proper.

2.02 SUBSTITUTIONS:

- A. **Conditions:** After the Bid Opening and approval of the Contractor's List of Materials submitted in accordance with the Supplementary General Conditions, the Contractor's request for a substitution will be received and considered when extensive revisions to the contract documents are not required, when the proposed changes are in keeping with the general intent of the contract documents, when the requests are timely, fully documented and properly submitted, and when one or more of the following conditions is satisfied, all as judged by the Designer; otherwise the requests will be returned without action except to record non-compliance with these requirements.
1. The Designer will consider a request for substitution where the request is directly related to an "or equal" clause or similar language in the contract documents.
 2. The Designer will consider a request for substitution where the specified product or method cannot be provided within the Contract Time. However, the request will not be considered if the product or method cannot be provided as a result of the Contractor's failure to pursue the work promptly or to coordinate the various activities properly.
 3. The Designer will consider a request for substitution where the specified product or method cannot receive necessary approval by a governing authority, and the requested substitution can be approved.
 4. The Designer will consider a request for a substitution where a substantial advantage is offered the Owner, in terms of cost, time, energy conservation or other considerations of merit, after deducting offsetting responsibilities the Owner may be required to bear. These additional responsibilities may include such considerations as additional compensation to the Designer for redesign and evaluation services, the increased cost of other work by the Owner or separate contractors, and similar considerations.
 5. The Designer will consider a request for substitution when the specified product or method cannot be provided in a manner which is compatible with other materials of the work, and where the Contractor certifies that the substitution will overcome the incompatibility.
 6. The Designer will consider a request for substitution when the specified product or method cannot be properly coordinated with other materials in the work, and where the Contractor certifies that the proposed substitution can be properly coordinated.
 7. The Designer will consider a request for substitution when the specified product or method cannot receive a warranty as required by the contract documents and where the contractor certifies that the proposed substitution receives the required warranty.
- B. **Work-Related Submittals:** The Contractor's submittal of and the Designer's acceptance of shop drawings, product data or samples which relate to work not complying with requirements of the contract documents, does not constitute an acceptable or valid request for a substitution, nor approval thereof.

2.03 GENERAL PRODUCT REQUIREMENTS:

- A. **General:** Provide products that comply with the requirements of the Contract documents and that are undamaged and, unless otherwise indicated, unused at the time of installation. Provide products that are complete with all accessories, trim, finish, safety guards and other devices and details needed for a complete installation and for the intended use and effect.
1. **Standard Products:** Where they are available, provide standard products of types that have been produced and used in similar situations on other projects.
 2. **Continued Availability:** Where, because of the nature of its application, the Owner is likely to need replacement parts or additional amounts of a product at a later date, either for maintenance and repair or

replacement, provide standard, domestically produced products for which the manufacturer has published assurances that the products and its parts are likely to be available to the Owner at a later date.

- B. Nameplates: Except as otherwise indicated for required labels and operating data, do not permanently attach or imprint manufacturer's or producer's nameplates or trademarks on exposed surfaces of products which will be exposed to view either in occupied spaces or on the exterior of the completed project.
 - 1. Labels: Locate required product labels and stamps on a concealed surface or, where required for observation after installation, on an accessible surface which, in occupied spaces, is not conspicuous.
 - 2. Equipment Nameplates: Provide a permanent nameplate on each item of service-connected or power-operated equipment. Locate the nameplate on an easily accessible surface which is inconspicuous in occupied spaces. The nameplate shall contain the following information and other essential operating data.
 - a) Name of manufacturer.
 - b) Name of product.
 - c) Model number.
 - d) Serial number.
 - e) Capacity.
 - f) Speed.
 - g) Ratings.
 - h) U.L. listed label on all electrical equipment.

PART 3 - EXECUTION

3.01 INSTALLATION OF PRODUCTS:

- A. General: Except as otherwise indicated in individual sections of these specifications, comply with the manufacturer's instructions and recommendations for installation of the products in the applications indicated. Anchor each product securely in place, accurately located and aligned with other work. Clean exposed surfaces and protect surfaces as necessary to ensure freedom from damage and deterioration at time of acceptance.

END OF SECTION 01 67 00

CUTTING AND PATCHING

PART 1 - GENERAL

1.01 RELATED DOCUMENTS:

- A. Drawings, Notice to Bidders and Standard General Conditions of the Construction Contract, including Supplementary General Conditions and Division-1 Specification sections, apply to work of this section.

1.02 DESCRIPTION OF REQUIREMENTS:

- A. Definition: "Cutting and patching" includes cutting into existing construction to provide for the installation or performance of other work and subsequent fitting and patching required to restore surfaces to their original condition.
 - 1. "Cutting and patching" is performed for coordination of the work, to uncover work for access or inspection, to obtain samples for testing, to permit alterations to be performed or for other similar purposes.
 - 2. Cutting and patching performed during the manufacturer of products, or during the initial fabrication, erection or installation processes is not considered to be "cutting and patching" under this definition. Drilling of holes to install fasteners and similar operations are also not considered to be "cutting and patching".
- B. Refer to other sections of these specifications for specific cutting and patching requirements and limitations applicable to individual units of work.
 - 1. Unless otherwise specified requirements of this section apply to Mechanical and Electrical work. Refer to Division 22 and 23 sections for additional requirements and limitations on cutting and patching of Mechanical and Electrical work.

1.03 QUALITY ASSURANCE:

- A. Requirements for Structural Work: Do not cut and patch structural work in a manner that would result in a reduction of load-carrying capacity or of load-deflection ratio.
- B. Before cutting and patching the following categories of work, obtain the Designer's approval to proceed with cutting and patching as described in the procedural proposal for cutting and patching.
 - 1. Structural steel.
 - 2. Miscellaneous structural metals, including lintels, equipment supports, stair systems and similar categories of work.
 - 3. Structural concrete.
 - 4. Miscellaneous structural metals, including lintels, equipment supports, Stair systems and similar categories of work.
 - 5. Foundation construction.
 - 6. Bearing and retaining walls.
 - 7. Structural decking.
 - 8. Exterior wall construction.
 - 9. Piping, ductwork, vessels and equipment.
- C. Operational and Safety Limitations: Do not cut and patch operational elements or safety related components in a manner that would result in a reduction of their capacity to perform in the manner intended, including energy performance, or that would result in increased maintenance, or decreased operational life or decreased safety.

- D. Visual Requirements: Do not cut and patchwork exposed on the building's exterior or in its occupied spaces, in a manner that would, in the Designer's opinion, result in lessening the building's aesthetic qualities. Do not cut and patch work in a manner that would result in substantial visual evidence of cut and patch work. Remove and replace work judged by the Designer to be cut and patched in a visually unsatisfactory manner.

1.04 SUBMITTALS:

- A. Procedural Proposal for Cutting and Patching: Where prior approval of cutting and patching is required, submit proposed procedures for this work well in advance of the time work will be performed and request approval to proceed. Include the following information, as applicable, in the submittal:
 - 1. Describe the nature of the work and how it is to be performed, indicating why cutting and patching cannot be avoided. Describe anticipated results of the work in terms of changes to existing work, including structural, operational, and visual changes as well as other significant elements.
 - 2. List products to be used and firms that will perform work.
 - 3. Give dates when work is expected to be performed.
 - 4. List utilities that will be disturbed or otherwise be affected by work, including those that will be relocated and those that will be out-of-service temporarily. Indicate how long utility service will be disrupted.
 - 5. Where cutting and patching of structural work involves the addition of reinforcement, submit details and engineering calculations to show how that reinforcement is integrated with original structure to satisfy requirements.
 - 6. Approval by the Designer to proceed with cutting and patching work does not waive the Designer's right to later require complete removal and replacement of work found to be cut and patched in an unsatisfactory manner.

PART 2 - PRODUCTS

2.01 MATERIALS:

- A. General: Except as otherwise indicated, or as directed by the Designer, use materials for cutting and patching that are identical to existing materials. If identical materials are not available, or cannot be used, use materials that match existing adjacent surfaces to the fullest extent possible with regard to visual effect. Use materials for cutting and patching that will result in equal-or-better performance characteristics.

PART 3 - EXECUTION

3.01 INSPECTION:

- A. Before cutting, examine the surfaces to be cut and patched and the conditions under which the work is to be performed. If unsafe or otherwise unsatisfactory conditions are encountered, take corrective action before proceeding with the work.

Before the start of cutting work, meet at the work site with all parties involved in cutting and patching, including mechanical and electrical trades. Review areas of potential interference and conflict between the various trades. Coordinate layout of the work and resolve potential conflicts before proceeding with the work.

3.02 PREPARATION:

- A. Temporary Support: To prevent failure provide temporary support of work to be cut.
- B. Protection: Protect other work during cutting and patching to prevent damage. Provide protection from adverse weather conditions for that part of the project that may be exposed during cutting and patching operations.

Avoid interference with use of adjoining areas or interruption of free passage to adjoining areas.

- C. Take precautions not to cut existing pipe, conduit or duct serving the building but scheduled to be relocated until provisions have been made to bypass them.

3.03 PERFORMANCE:

- A. General: Employ skilled workmen to perform cutting and patching work. Except as otherwise indicated or as approved by the Designer, proceed with cutting and patching at the earliest feasible time and complete work without delay.
- B. Cutting: Cut the work using methods that are least likely to damage work to be retained or adjoining work. Where possible review proposed procedures with the original installer; comply with original installer's recommendations.
 - 1. In general, where cutting is required use hand or small power tools designed for sawing or grinding, not hammering and chopping. Cut through concrete and masonry using a cutting machine such as a carborundum saw or core drill to insure a neat hole. Cut holes and slots neatly to size required with minimum disturbance of adjacent work. To avoid marring existing finished surfaces, cut or drill from the exposed or finished side into concealed surfaces. Temporarily cover openings when not in use.
 - 2. By-pass utility services such as pipe and conduit, before cutting, where such utility services are shown or required to be removed, relocated or abandoned. Cut-off conduit and pipe in walls or partitions to be removed. After by-pass and cutting, cap, valve or plug and seal tight remaining portion of pipe and conduit to prevent entrance of moisture or other foreign matter.
- C. Patching: Patch with seams which are durable and as invisible as possible. Comply with specified tolerances for the work.
 - 1. Where feasible, inspect and test patched areas to demonstrate integrity of work.
 - 2. Restore exposed finishes of patched areas and where necessary extend finish restoration into retained adjoining work in a manner which will eliminate evidence of patching and refinishing.

3.04 CLEANING:

- A. Thoroughly clean areas and spaces where work is performed or used as access to work. Remove completely point, mortar, oils, putty and items of similar nature. Thoroughly clean piping, conduit and similar features before painting or other finishing is applied. Restore damaged pipe covering to its original condition.

END OF SECTION 01 73 29

DIVISION 07

THERMAL AND MOISTURE PROTECTION

PENETRATION FIRESTOPPING

PART 1 - GENERAL

1.01 SUMMARY

A. Section Includes:

1. Penetrations in fire-resistance-rated walls.
2. Penetrations in horizontal assemblies.
3. Penetrations in smoke barriers.

1.02 ACTION SUBMITTALS

A. Product Data: For each type of product.

1.03 INFORMATIONAL SUBMITTALS

A. Product test reports.

1.04 CLOSEOUT SUBMITTALS

A. Installer Certificates: From Installer indicating that penetration firestopping systems have been installed in compliance with requirements and manufacturer's written instructions.

1.05 QUALITY ASSURANCE

A. Installer Qualifications: A firm that has been approved by FM Global according to FM Global 4991, "Approval of Firestop Contractors," or been evaluated by UL and found to comply with its "Qualified Firestop Contractor Program Requirements."

PART 2 - PRODUCTS

2.01 PERFORMANCE REQUIREMENTS

A. Fire-Test-Response Characteristics:

1. Perform penetration firestopping system tests by a qualified testing agency acceptable to authorities having jurisdiction.
2. Test per testing standards referenced in "Penetration Firestopping Systems" Article. Provide rated systems complying with the following requirements:
 - a. Penetration firestopping systems shall bear classification marking of a qualified testing agency.
 - 1) UL in its "Fire Resistance Directory."
 - 2) Intertek Group in its "Directory of Listed Building Products."
 - 3) FM Global in its "Building Materials Approval Guide."

2.02 PENETRATION FIRESTOPPING SYSTEMS

A. Penetration Firestopping Systems: Systems that resist spread of fire, passage of smoke and other gases, and maintain original fire-resistance rating of construction penetrated. Penetration firestopping systems shall be compatible with one another, with the substrates forming openings, and with penetrating items if any.

1. Manufacturers: Subject to compliance with requirements, provide products by one of the following:
 - a. 3M Fire Protection Products.
 - b. A/D Fire Protection Systems Inc.
 - c. Construction Solutions.
 - d. Grabber Construction Products.
 - e. Hilti, Inc.
 - f. HOLDRITE; Reliance Worldwide Company.
 - g. NUCO Inc.
 - h. Passive Fire Protection Partners.
 - i. Specified Technologies, Inc.
 - j. STC Sound Control.
 - k. Tremco, Inc.

- B. Penetrations in Fire-Resistance-Rated Walls: Penetration firestopping systems with ratings determined per ASTM E 814 or UL 1479, based on testing at a positive pressure differential of 0.01-inch wg (2.49 Pa).
 1. F-Rating: Not less than the fire-resistance rating of constructions penetrated.

- C. Penetrations in Horizontal Assemblies: Penetration firestopping systems with ratings determined per ASTM E 814 or UL 1479, based on testing at a positive pressure differential of 0.01-inch wg (2.49 Pa).
 1. F-Rating: At least one hour, but not less than the fire-resistance rating of constructions penetrated.
 2. T-Rating: At least one hour, but not less than the fire-resistance rating of constructions penetrated except for floor penetrations within the cavity of a wall.
 3. W-Rating: Provide penetration firestopping systems showing no evidence of water leakage when tested according to UL 1479.

- D. Penetrations in Smoke Barriers: Penetration firestopping systems with ratings determined per UL 1479, based on testing at a positive pressure differential of 0.30-inch wg (74.7 Pa).
 1. L-Rating: Not exceeding 5.0 cfm/sq. ft. (0.025 cu. m/s per sq. m) of penetration opening at and no more than 50-cfm (0.024-cu. m/s) cumulative total for any 100 sq. ft. (9.3 sq. m) at both ambient and elevated temperatures.

- E. Exposed Penetration Firestopping Systems: Flame-spread and smoke-developed indexes of less than 25 and 450, respectively, per ASTM E 84.

- F. Accessories: Provide components for each penetration firestopping system that are needed to install fill materials and to maintain ratings required. Use only those components specified by penetration firestopping system manufacturer and approved by qualified testing and inspecting agency for conditions indicated.

PART 3 - EXECUTION

3.01 INSTALLATION

- A. Examine substrates and conditions, with Installer present, for compliance with requirements for opening configurations, penetrating items, substrates, and other conditions affecting performance of the Work.

- B. General: Install penetration firestopping systems to comply with manufacturer's written installation instructions and published drawings for products and applications.

- C. Install forming materials and other accessories of types required to support fill materials during their application and in the position needed to produce cross-sectional shapes and depths required to achieve fire ratings.

1. After installing fill materials and allowing them to fully cure, remove combustible forming materials and other accessories not forming permanent components of firestopping.

D. Install fill materials by proven techniques to produce the following results:

1. Fill voids and cavities formed by openings, forming materials, accessories and penetrating items to achieve required fire-resistance ratings.
2. Apply materials so they contact and adhere to substrates formed by openings and penetrating items.
3. For fill materials that will remain exposed after completing the Work, finish to produce smooth, uniform surfaces that are flush with adjoining finishes.

3.02 IDENTIFICATION

- A. Wall Identification: Permanently label walls containing penetration firestopping systems with the words "FIRE AND/OR SMOKE BARRIER - PROTECT ALL OPENINGS," using lettering not less than 3 inches (76 mm) high and with minimum 0.375-inch (9.5-mm) strokes.

1. Locate in accessible concealed floor, floor-ceiling, or attic space at 15 feet (4.57 m) from end of wall and at intervals not exceeding 30 feet (9.14 m).

- B. Penetration Identification: Identify each penetration firestopping system with legible metal or plastic labels. Attach labels permanently to surfaces adjacent to and within 6 inches (150 mm) of penetration firestopping system edge so labels are visible to anyone seeking to remove penetrating items or firestopping systems. Use mechanical fasteners or self-adhering-type labels with adhesives capable of permanently bonding labels to surfaces on which labels are placed. Include the following information on labels:

1. The words "Warning - Penetration Firestopping - Do Not Disturb. Notify Building Management of Any Damage."
2. Contractor's name, address, and phone number.
3. Designation of applicable testing and inspecting agency.
4. Date of installation.
5. Manufacturer's name.
6. Installer's name.

3.03 FIELD QUALITY CONTROL

- B. Where deficiencies are found or penetration firestopping system is damaged or removed because of testing, repair or replace penetration firestopping system to comply with requirements.
- C. Proceed with enclosing penetration firestopping systems with other construction only after inspection reports are issued and installations comply with requirements.

END OF SECTION 07 84 13

DIVISION 23

MECHANICAL REQUIREMENTS

BASIC MECHANICAL REQUIREMENTS

PART 1 - GENERAL

1.01 RELATED DOCUMENTS AND RELATED WORK SPECIFIED ELSEWHERE:

A. Related Documents

1. Drawings, Standard General Conditions of the Construction Contract, including Supplementary General Conditions, Division 01 Specification sections and other Division 23 specification sections and Division 26 specifications apply to work of this section.

1.02 REFERENCES & INTENT

- A. All work of this Division shall comply with the requirements of the Drawings, General Conditions, Supplementary General Conditions and Division 01 Specifications section.
- B. Study all drawings and specifications before submitting bids.
- C. Work under this Division includes all essential labor, materials, tools, equipment, transportation, insurance, temporary protection, supervision and incidental items for proper installation and operation of all systems even though not specifically mentioned or indicated.
- D. Drawings are diagrammatic. Drawings are not intended to be absolutely precise and do not specify or show every offset, fitting, and component. The purpose of the drawings is to indicate a system concept, the main components of the systems, and the approximate geometrical relationships. Based on the system's concept, the main components, and the approximate geometrical relationships, the contractor shall provide all other components and materials necessary to make the systems fully complete and operational. Contractor shall route piping or provide offsets to avoid interference with structural elements, equipment, electrical panels and junction boxes, etc. Verify locations, dimensions, flow directions, etc. before construction.
- E. It is the intent of these specifications and drawings to provide for finished systems of the quality specified, properly tested, balanced and ready for operation. This includes all devices and accessories required to make the work complete even though such items may not be expressly shown or specified. Drawings and specifications are complementary and must be so construed to determine the full scope of work.
- F. Brand names and catalog numbers included with equipment or materials specifications are used to indicate quality, rating, or operating characteristics of the equipment or material.
- G. Jobsite Conditions. The Contractor shall visit the site and familiarize himself with the existing conditions before submitting his bid. Failure to do so does not relieve the Contractor from completing the work as specified herein and after. Requests for additional payments due to the Contractor's failure to allow for work conditions will be rejected.

1.03 WORK INCLUDED

- A. The following work is specifically included without limiting the generality implied by these specifications and drawings.
 1. All mechanical scope of work specified herein and as shown on the plans. Contractor should review all drawings and include all items that are a part of his scope.
 2. All associated wiring, cutting and patching.

- B. Bidders shall examine equipment plans and specifications and include in their bids all labor and material required for complete installation and connection of equipment which is properly a part of their trade even if it is not provided in the equipment specifications.

1.04 STANDARDS AND CODES

- A. All equipment with electrical components shall bear the UL label.
- B. Standards by the following organizations shall be complied with wherever applicable:
 - 1. ANSI American National Standards
 - 2. ASHRAE American Society of Heating, Refrigerating and Air-Conditioning Engineers
 - 3. ASTM American Society for Testing Material
 - 4. NEC National Electric Code
 - 5. NEMA National Electrical Manufacturers Association
 - 6. NFPA National Fire Protection Association
 - 7. OSHA Occupational Safety and Health Act
 - 8. SMACNA Sheet Metal and Air Conditioning Contractors National Association, Inc.
 - 9. North Carolina State Building Code - 2018
 - 10. Any Other Applicable local and State Codes
- C. In the event there are conflicts between specifications and standards or codes, standards or codes shall govern unless specifications are in excess of standards.

1.05 PERMITS AND FEE

- A. Make application for all necessary permits and pay applicable fees.

1.06 STRUCTURAL STEEL AND CONCRETE

- A. Structural members may not be pierced without prior written approval of the Engineer.

1.07 WATERPROOFING

- A. Waterproofed floors and walls may not be cut.

1.08 WORK SCHEDULE:

- A. Work schedule shall be in accordance with Division 01.
- B. The existing facilities shall remain in use during all phases of construction under this Contract. The Contractor shall cooperate with the Owner in every way possible to keep interruption of, and interference with, normal functions, activities, and operations to a minimum. Where construction or attendant work interrupts normal functions in any area, a schedule of work shall be submitted for approval of the Owner and after approval, strictly followed. Modification to existing work shall be done as required. All work shall be performed in such a manner as to prevent any interruption of any service or utility. Where it is necessary to interrupt service for cut-in or changeover, the work shall be scheduled well in advance of the interruption and the interruption approved by the Owner. If required by Owner, changeover work shall be done during night, weekends, holidays, or other off-peak period as approved. Existing piping, ductwork, etc., shall be modified as indicated on the drawings and/or as required by new and modified construction. Existing piping, ductwork, etc., modified as required, shall be put back in first class operating condition. Existing equipment, piping, and sheet metal work to be removed shall become the property of the Contractor and be removed from the site and disposed of in a legal means unless otherwise indicated. No equipment shall be disconnected without approval by the Engineer. Existing piping buried in building construction shall be left in place and capped behind new finish. All temporary relocation of equipment, temporary piping, sheet metal work, etc. required for temporary operation of the facility shall be provided.

- C. Any demolition or installation work producing excessive dust or noise deemed to be disruptive or possibly unsafe to building operations must be, at the Owner's discretion, performed after normal working hours.

1.09 PROTECTION OF EQUIPMENT

- A. Provide all necessary protection and be fully responsible for material and equipment stored or installed on the site. Material or equipment stolen or damaged shall be replaced at no additional cost to the Owner.
- B. Provide protection against theft, physical damage and the entry of dirt, water or corrosive fumes into the material and equipment. Maintain protective covers for the duration of construction. Store equipment, such as controls, subject to damage by moisture and temperature extremes in a dry, heated space.

1.10 FIRE SAFETY

- A. Fire Watch: Provide a fire watch wherever welding, brazing, cutting or other processes involving an open flame or potential for generating sparks is used. Fire watch shall consist of a person with a 10 pound carbon dioxide fire extinguisher. While on fire watch, the person so assigned shall have no other duties or assignments.
- B. Fire Blanket: In addition to providing a fire watch, use an approved fire blanket to cover any combustible materials in the immediate area.

1.11 GUARANTEES

- A. Furnish written guarantee in accordance with requirements of General Conditions. Partial approval of a portion of work does not affect the validity of guarantee.

1.12 SHOP DRAWINGS

- A. It shall be noted that shop drawing submittals processed by the Engineer are not change orders; that the purpose of shop drawing submittals is to demonstrate to the Engineer that the Contractor understands the design concept, that he demonstrates his understanding by indicating which equipment and material he intends to furnish and install, and by detailing the fabrication and installation methods he intends to use. If deviations, discrepancies or conflicts between shop drawing submittals and the contract documents in the form of design drawing and specifications are discovered either prior to or after shop drawing submittals are processed by the Engineer, the design drawings and specifications shall control and shall be followed. The Engineer may also require the contractor to submit samples of proposed or specified equipment for approval with the samples to be returned to the contractor upon request. During the submittal process, if the contractor submits equipment which is not EXACTLY like the equipment specified, the contractor shall provide a list of those differences to the engineer for his review and approval. If the contractor's list is incomplete, and the submittal is approved, the approval does not waive the differences that were not submitted for review.
- B. The design documents indicate the products that were used as the basis of design. This establishes the product parameters and other systems interacting with the product (size, power requirements, pipe sizes, pump capacity, etc.) The contractor shall specifically bring to the designer's attention any changes in other systems required when products other than those used as the basis of design, are used. The contractor shall bear all costs, including design, for the changes.
- C. Prior to procurement or manufacturing, submit for approval appropriate shop drawings and/or descriptive literature giving performance data, physical size, wiring diagrams, configuration, capacity, material, etc., for all items under this Division including the following:
 - 1. Chiller
 - 2. Pumps
 - 3. Adjustable Speed Drives
 - 4. Pipe and Pipe Fittings, Piping Specialties, Hydronic Specialties

5. Supports, Anchors, and Vibration Isolation
6. Painting and Identification
7. Valves
8. Insulation
9. Testing and Balancing
10. DDC Control System
11. Instrumentation
12. Water Conditioning Chemicals and Test Procedures
13. Electric motors, disconnects, or other electrical components not included in other submittals

- D. The contractor shall visit the site and familiarize himself with the project requirements and the field conditions before preparing shop drawings and ordering equipment. Field verify the characteristics of all specified or existing equipment before preparing shop drawings. This shall include available space, available voltages, suitability of substrate for receiving the specified equipment, etc. Where existing equipment is re-used, he shall verify dimensions, capacities, horse-power, etc. and bring any discrepancies to the attention of the Engineer.
- E. Where different products have to work together, it is the Contractor's responsibility to select manufacturers whose products are visually and/or technically compatible.
- F. Prepare listing of all equipment and materials for the project. A sample schedule is included at the end of this section to complete this requirement. Provide all information represented.
- G. Submittals of shop drawings and manufacturer's data, etc. shall be provided to the Designers electronically in PDF format. The Designer will review the submittals and return them electronically. The exception would be color samples or other material that cannot be adequately represented electronically, and these should be submitted as five (5) hard copies. The Designer will review them and return three (3) copies.

1.13 RECORD DOCUMENTS

- A. During construction, keep an accurate record of all changes and deviations from contract documents. Upon completion of this installation, the contractor shall submit to the Designer maintenance manuals and colored scans of the marked-up prints in PDF format indicating any installed work that is different from what is shown on the drawings.

PART 2 – PRODUCTS

2.01 QUALITY OF MATERIAL

- A. Equipment of the same general type shall be of the same make. Reference is made to relays, motors, valves, motor starters, contactors, etc.
- B. Brand names and catalog numbers included with equipment or material specifications are used to indicate quality, rating or operating characteristics of the equipment or material.
- C. All materials provided shall be new and shall be approved and labeled by the Underwriter's Laboratories, Inc., or other accredited third-party agency, wherever such agency has applicable standards. All work shall be accomplished in a neat, workmanlike manner by experienced journeymen. All work shall be performed at such times as are required by the progress of the job.
- D. All components, equipment and systems shall comply with the latest edition adopted by the State of North Carolina of ASHRAE 90.1, ASHRAE 62.1, ASHRAE 15 and any other applicable ASHRAE standard.

PART 3 - EXECUTION

3.01 CLEARANCE AND RESTORATION OF SITE

- A. It may be required to temporarily remove existing ceiling tiles, piping, duct, conduits, etc. to introduce new work as specified in this Division. Contractor, after installation of new work, shall reinstall, reconnect removed items to match the existing. Provide offsets if required in existing piping, ducts etc. to introduce new work.

3.02 RATED ASSEMBLIES

- A. Installation of any equipment shall not compromise fire ratings of rated assemblies. All penetrations shall be sealed per UL guidelines for penetration protections. Provide fire dampers or combination fire and smoke dampers where required by code.

3.03 COORDINATION

- A. Install all work to permit removal of equipment without damage to the equipment or the building. Verify equipment space requirements, condition of substrate, voltages, etc. at the time of shop drawing submission and advise the Engineer of any conflict.
- B. Coordinate equipment locations as well as piping and conduit routing with Owner's representative to optimize all present and foreseen future space usage and clearance requirements.
- C. Do not rough prior to receipt of approved shop drawings.

3.04 EQUIPMENT INSTALLATION AND SUPPORT

- A. Install all equipment where indicated, in accordance with manufacturer's published installation instructions, and with recognized industry practices to ensure that equipment complies with requirements and serves intended purposes. Consult with Engineer if said instructions or practices conflict with the drawings/specifications.
- B. The manufacturer's installation instructions shall be available on the job site at the time of inspection and start-up as required by NC Mechanical Code 304.1.
- C. Support plumb, rigid and true to line all work and equipment furnished under this Division. Study thoroughly architectural, mechanical drawings and all related drawings to determine how equipment, piping, ductwork, etc., are to be supported, mounted or suspended. Provide extra steel bolts, inserts, pipe stands, brackets and accessories for proper support as required whether or not shown on drawings. When directed, furnish for approval a drawing showing supports.
- D. Any system component which may require maintenance, such as control valves, manual valves, strainers, etc. shall not be installed over electrical equipment, machinery, control panels or floor openings.

3.05 FINAL ADJUSTMENT AND TESTING

- A. General - Provide all testing, preliminary and final adjustment of instrumentation for this purpose. Conduct all tests in full compliance with applicable codes prior to covering or concealing work by insulation, enclosures, etc. Material found to be defective shall not be repaired. It shall be replaced with new material which tests satisfactorily. Defective workmanship shall be corrected.
- B. Working Tests - Subject all equipment and controls to simultaneous and continuous working tests for a period of one day prior to final inspection. Make adjustments, repairs and equipment replacements as required.

3.06 LABELS, IDENTIFICATION AND TAGS

- A. All components or equipment shall be identified using permanent engraved nameplates, permanently attached with pin-head screws to device or to wall or mounting panel above device. Stick-on type labels will not be acceptable.
- B. Label and identify all piping installed under this contract. Install plastic pipe markers or stenciling after finish painting has been completed.
- C. Refer to Section 23 05 90 – Mechanical Painting and Identification.

3.07 OWNER'S RIGHT TO TEST SYSTEMS

- A. Should, in the opinion of the Engineer, and during the guarantee period, reasonable doubt exist as to the proper functioning of any equipment installed under this Contract, the right is reserved for the Owner and Engineer to perform any test deemed practical to determine whether such equipment is functioning properly and performing at required capacity. If such tests show proper functioning, the cost of the test will be paid by the Owner. If the tests indicate a deficiency in equipment capacity or performance, the Contractor shall pay the cost of the test and also make good any deficiencies shown by the test to the full satisfaction of the Owner and the Engineer.

3.08 CLEANING UP

- A. The contractors performing work under this section shall at all times keep the premises and the building in a neat and orderly condition and any instructions of the Engineer in regard to the storing of material, protective measures, cleaning up of debris, etc. shall be explicitly followed. At the completion of the job, all equipment shall be cleaned to the satisfaction of the Owner.
- B. The building will be occupied during installation of the new addition and/or alterations as described hereinafter. Thus, special care shall be taken during installation to protect equipment and other furniture in the buildings from dust and debris generated during installation of work specified in this Division.

3.09 INSPECTION CERTIFICATES

- A. Obtain all inspections required by law, ordinances, rules, and regulations of the Authorities having jurisdiction and obtain and furnish to the Engineer certificates of such inspections, pay all fees, charges, and other expenses in connection therewith.

3.10 DESIGNER INSPECTIONS

- A. The designer will make regular site visits during construction and will keep a deficiency log of all observed exceptions. The contractor shall resolve these noted deficiencies as expediently as possible.

3.11 FINAL REVIEW

- A. Final review and tests of the completed construction shall be performed in the presence of the Engineer or his representative and shall be at such times as are convenient to the Engineer. Final tests shall show conclusively that all equipment performs its specified function and that all work complies with the provisions of these specifications. All material, equipment, and instruments required for the tests shall be furnished by the Contractor at his own expense.

3.12 EQUIPMENT DELIVERY AND PROTECTION

- A. All material shall be delivered and unloaded by the Contractor within the project site as directed by the Owner.
- B. The Contractor shall protect all material and equipment from breakage, theft or weather damage.

3.13 OPERATING INSTRUCTIONS

- A. The Contractor shall provide a minimum of three (3) hours of personal instruction to Owner's personnel in the proper operation of all equipment specified and provided. The instruction shall be provided by factory trained and certified competent personnel. The instruction shall include but not be limited to the following:
 - 1. Instructions for the operation of the chillers, pumps, ASDs, and new DDC controls.
- B. If off-site instruction is required, the contractor shall include in his bid the cost of boarding, lodging and transportation of three people from Carrboro, NC to the training site. The cost shall also include all costs during the training period.

3.14 MAINTENANCE MANUALS

- A. Maintenance Manuals shall be submitted in three (3) hard copies in vinyl 3-ring binders, and three (3) copies in electronic format as PDF files on disks. Each manual shall have the following:
 - 1. Service telephone number of the installing company, including an emergency number.
 - 2. Maintenance and emergency repair contact information shall be provided for all equipment both in the manual and on labels to be placed on an easily visible location on equipment.
 - 3. Contact person, phone number, and address of manufacturer or distributor where equipment was purchased.
 - 4. The manufacturing company's operating and maintenance manuals for each piece of equipment.
 - 5. Consolidated list of maintenance procedures and maintenance / spare parts recommended by the equipment manufacturers. The spare parts list shall give the correct manufacturer, model / part number, correct size and recommended quantities of spares.
 - 6. Copies of all approved shop drawings.
 - 7. Copies of warranties with their start dates.
 - 8. A diagram of all new valve locations, giving their identification and function. This shall be submitted to the Designer and Owner for review and approval as part of the O&M manual, and to be mounted as indicated below.
- B. Furnish for each building permanent type charts, framed under clear plastic, mounted in at least one mechanical room on each floor or where directed as follows:
 - 1. Service organizations with day and night telephone numbers.
 - 2. A diagram of all new valve locations, giving their identification and function.

PRODUCTS LISTING FORM

INSTRUCTIONS:

Do not use the terminology "as specified"; rather indicate specifically the product proposed.

Prepared by: _____

Date: _____ Project: _____

<u>SPEC. SECTION</u>	<u>ITEM</u>	<u>MANUFACTURER</u>

END OF SECTION 23 05 10

PART 1 - GENERAL

1.01 RELATED DOCUMENTS:

- A. Drawings, Standard General Conditions of the Construction Contract, including Supplementary General Conditions, Division 01 Specification sections, and other Division 23 sections apply to work of this section.

1.02 DESCRIPTION OF WORK

- A. Extent of piping specialties required is indicated on drawings and/or specified in other Division 23 sections, and by requirements of this section.

1.03 SUBMITTALS:

- A. Manufacturer's Data: Submit manufacturer's technical product data, including installation instructions, and dimensioned drawings for each type of manufactured piping specialty. Include pressure drop curve or chart for each type and size of piping specialty. Submit schedule showing manufacturer's figure number, size, location, and features for each required piping specialty.

PART 2 - PRODUCTS

2.01 PIPE ESCUTCHEONS:

- A. General: Provide pipe escutcheons as specified herein with inside diameter closely fitting pipe outside diameter, or outside of pipe insulation where pipe is insulated. Select outside diameter of escutcheon to completely cover pipe penetration hole in floors, walls or ceilings; and pipe sleeve extension, if any. Furnish pipe escutcheons with nickel or chrome finish for occupied areas, prime paint finish for unoccupied areas.
- B. Pipe Escutcheons for Moist Areas: For waterproof floors, and areas where water and condensation can be expected to accumulate, provide cast brass or sheet brass escutcheons, solid or split hinged.
- C. Pipe Escutcheons for Dry Areas: Provide stamped steel escutcheons, solid or split hinged, 22 gauge minimum.

2.02 DIELECTRIC UNIONS:

- A. General: Provide standard products recommended by manufacturer for use in service indicated, which effectively isolate ferrous from non-ferrous piping (electrical conductance), prevent galvanic action, and stop corrosion.

2.03 FIRE BARRIER PENETRATION SEALS:

- A. Provide seals for any opening through fire-rated walls, floors, or ceilings used as passage for mechanical components such as piping or ductwork in accordance with UL penetration protection guidelines with UL approved components. Refer to fire barrier penetration detail(s) in construction drawings.

2.04 DIAL THERMOMETERS:

- A. General: Provide dial thermometers for remote reading applications as shown on plans and/or as otherwise required by field conditions.
- B. Case: 3-1/2 in. diameter aluminum case, flush mount, back connection.

- C. Actuation: Gas actuated, filled with nontoxic, inert gas.
- D. Tube and Capillary: Stainless steel capillary, stainless steel spiral interlocked armor, length as required, bulb style and size to suit application.

2.05 THERMOMETER WELLS:

- A. General: Provide thermometer wells constructed of stainless steel, pressure rated to match piping system design pressure. Provide 2" extension for insulated piping. Provide cap nut with chain fastened permanently to thermometer well.

2.06 TEMPERATURE GAGE CONNECTOR PLUGS ("Pete's Plug"):

- A. General: Provide temperature gage connector plugs rated for 500 psi and 250 deg.F. Construct of brass and finish in nickel-plated, equip with 1/2" NPS fitting, with self-sealing valve core type neoprene gasketed orifice suitable for inserting 1/8" O.D. probe assembly from dial type insertion thermometer. Equip orifice with gasketed screw cap and chain. Provide extension, length equal to insulation thickness, for insulated piping.

2.07 PRESSURE GAGES:

- A. General: Provide glass pressure gages of materials, capacities, and ranges indicated, designed and constructed for use in service indicated. Pressure gages shall be Ashcroft, Weksler, H.O. Trerice, or equivalent.
- B. Type: General use, 1% accuracy, ANSI B40.1 grade A, phosphor bronze bourdon type, bottom connection.
- C. Case: Drawn steel or brass, glass lens, 4-1/2" diameter.
- D. Connector: Brass with 1/4" male NPT. Provide protective syphon when used for steam service.
- E. Scale: White coated aluminum, with permanently etched markings.
- F. Range: Conform to the following:
 1. Vacuum: 30" Hg- 15 psi
 2. Water: 0 - 160 psi

2.08 PRESSURE GAGE COCKS

- A. General: Provide pressure gage cocks between pressure gage and gage tees on piping systems. Construct gage cock of brass with 1/4" female NPT on each end, and "T" handle brass plug.
- B. Syphon: 1/4" straight coil constructed brass tubing with 1/4" male NPT on each end.
- C. Snubber: 1/4": brass bushing with corrosion resistant porous metal disc, through which pressure fluid is filtered. Select disc material for fluid served and pressure rating.

2.09 PRESSURE GAGE CONNECTOR PLUGS ("Pete's Plug"):

- A. General: Provide pressure gage connector plugs rated for 500 psi and 250 deg.F. Construct of brass and finish in nickel-plated, equip with 1/2" NPS fitting, with self-sealing valve core type neoprene gasketed orifice suitable for inserting 1/8" O.D. probe assembly from dial type insertion pressure gage. Equip

orifice with gasketed screw cap and chain. Provide extension, length equal to insulation thickness, for insulated piping.

2.10 FABRICATED PIPING SPECIALTIES:

- A. Drip Pans: Provide drip pans fabricated from corrosion-resistant sheet metal with watertight joints, and with edges turned up 2-1/2". Reinforce top, either by structural angles or by rolling top over 1/4" steel rod. Provide hole, gasket, and flange at low point for watertight joint and 1" drain line connection.
- B. Pipe Sleeves: Provide pipe sleeves of one of the following: (except where allowed otherwise in non-load bearing and non-fire barrier partitions).
 - 1. Steel-Pipe: Fabricate from Schedule 40 galvanized or black steel pipe; remove burrs.
 - 2. Iron-Pipe: Fabricate from cast-iron or ductile iron pipe; remove burrs.

PART 3 - EXECUTION

3.01 INSTALLATION OF PIPING SPECIALTIES:

- A. Pipe Escutcheons: Install pipe escutcheons on each pipe penetration through floors, walls, partitions, and ceilings where penetration is exposed to view and on exterior of building. Secure escutcheon to pipe or insulation so escutcheon covers penetration hole and is flush with adjoining surfaces.
- B. Dielectric Unions: Install at each piping joint between ferrous and non-ferrous piping. Comply with manufacturer's installation instructions.
- C. Fire Barrier Penetration Seals: Comply with UL guidelines and refer to details in drawings.

3.02 INSTALLATION OF TEMPERATURE GAGE

- A. General: Install temperature gages in vertical upright post and tilted so as to be easily read by observer standing on floor.
- B. Thermometer Wells: Install in piping tee where indicated, in vertical upright post. Fill well with oil or graphite, secure cap. Install a spare well within twelve inches of each temperature sensor installed under the temperature control section.
- C. Temperature Gage Connector Plugs: Install in piping tee where indicated, located on pipe at most readable position. Secure cap.

3.03 INSTALLATION OF PRESSURE GAGES

- A. General: Install pressure gages in piping tee with pressure gage cock, located on pipe at most readable position. If the gage cannot be read from the floor, a sensor shall be substituted in the piping and a digital readout device located where it can be read from the floor.
- B. Pressure Gage Cock: Install in piping tee with snubber. Install syphon for steam pressure gages.
- C. Pressure Gage Connector Plugs: Install in piping tee where indicated, located on pipe at most readable position. Secure cap.

3.04 INSTALLATION OF FABRICATED PIPING SPECIALTIES:

- A. Drip Pans: Locate drip pans under piping passing over or within 3' horizontally of electrical equipment, and elsewhere as indicated. Hang from structure with rods and building attachments, weld rods to sides of drip pan. Brace to prevent sagging or swaying. Connect 1" drain line to drain connection and run to nearest

plumbing floor drain or elsewhere as indicated.

- B. Pipe Sleeves: Install pipe sleeves where piping passes through walls, floors, ceilings, and roofs. Do not install sleeves through structural members of work, except as detailed on drawings, or as reviewed by Engineer. Install sleeves accurately centered on pipe runs. Size sleeves so that piping and insulation (if any) will have free movement in sleeve, including allowance for thermal expansion; but not less than 2 pipe sizes larger than pipe run. Where insulation includes vapor-barrier jacket, provide sleeve with sufficient clearance for installation.
1. Install length of sleeve equal to thickness of construction penetrated, and finish flush to surface; except floor sleeves. Extend floor sleeves 1/4" above level floor finish, and 3/4" above floor finish sloped to drain. Provide temporary support of sleeves during placement of concrete and other work around sleeves, and provide temporary closure to prevent concrete and other materials from entering sleeves.
 2. All interior pipe sleeves shall be Schedule 40 steel, unless otherwise noted.
 3. Install iron-pipe sleeves at exterior penetrations, both above and below grade.
 4. Sleeves through non-bearing partition walls shall be 18-gauge galvanized iron with lock seam joints braced to prevent collapsing.
 5. Sleeves through poured concrete walls or bearing walls, floors and beams shall be Schedule 40 pipe, at least two sizes larger than pipe.
 6. Sleeves shall be of sufficient size to receive insulation and of proper length to terminate above finished floors and flush with other finished surfaces.
 7. Sleeves through exterior walls below grade shall have anchor arms and shall be caulked watertight with lead and oakum.
 8. Pipe sleeves between floors and in mechanical room walls shall be caulked to prevent transmission of noise, air, and water.
 9. Sleeves for piping through fire partitions and walls shall be made air and vapor tight by installation in accordance with fire wall penetration details provided in construction drawings.

3.03 ADJUSTING AND CLEANING:

- A. Adjusting: Adjust faces of meters and gages to proper angle for best visibility.
- B. Cleaning: Clean windows of meters and gages and factory-finished surfaces. Replace cracked or broken windows, repair any scratched or marred surfaces with manufacturer's touch-up paint.

END OF SECTION 23 05 20

PART 1 - GENERAL

1.01 RELATED DOCUMENTS AND RELATED WORK SPECIFIED ELSEWHERE:

A. Related Documents

1. Drawings, Standard General Conditions of the Construction Contract, including Supplementary General Conditions, Division 01 Specification sections and other Division 23 specification sections apply to work of this section.

1.02 DESCRIPTION OF WORK:

- A. Extent of valves required is indicated on drawings and/or specified in other Division 23 sections, and by requirements of this section.

1.03 QUALITY ASSURANCE:

- A. Valve Types: Provide valves of same type by same manufacturer.

- B. Valve Identification: Provide valves with manufacturer's name (or trademark) and pressure rating clearly marked on valve body.

C. Codes and Standards:

1. MSS (Manufacturers Standardization Society of the Valve and Fittings Industry) Compliance: Mark valves in accordance with MSS-25 "Standard Marking System for Valves, Fittings, Flanges and Unions."
2. ANSI Compliance: For face-to-face and end-to-end dimensions of flanged- or welded-end valve bodies, comply with ANSI B16.10 "Face-to-Face and End-to-End Dimensions of Ferrous Valves."

1.04 SUBMITTALS:

- A. Manufacturer's Data: Submit manufacturer's technical product data, including installation instructions for each type of valve. Include pressure drop curve or chart for each type and size of valve. Submit valve schedule showing Manufacturer's figure number, size, location, and valve features for each required valve.

PART 2 - PRODUCTS

2.01 VALVES:

- A. General: Provide factory-fabricated valves recommended by manufacturer for use in service indicated. Provide valves of types and pressure ratings indicated; provide proper selection as determined by Installer to comply with installation requirements. Provide end connections which properly mate with pipe, tube, and equipment connections. Where more than one type is indicated, selection is Installer's option.

- B. Sizes: Unless otherwise indicated, provide valves of same size as upstream pipe size.

- C. Operators: Provide handwheels, fastened to valve stem, for valves other than quarter-turn. Provide lever handle for quarter-turn valves, 6" and smaller, other than plug valves. Provide gear operators for quarter-turn valves 8" and larger. Provide chain-operated sheaves and chains for overhead valves 8" and larger or as indicated.

2.02 GATE VALVES:

A. Comply with the following standards:

1. Cast-Iron Valves: MSS SP-70
2. Bronze Valves: MSS SP-80
3. Steel Valves: ANSI B16.34

2.03 GLOBE VALVES:

A. Comply with the following standards:

1. Cast-Iron Valves: MSS SP-85
2. Bronze Valves: MSS SP-80
3. Steel Valves: ANSI B16.34

2.04 BALL VALVES:

A. Comply with the following standards:

1. Cast-Iron Valves: MSS SP-72
2. Bronze Valves: MSS SP-110
3. Steel Valves: ANSI B16.34

2.05 BUTTERFLY VALVES:

A. Comply with MSS SP-67, "lug" type; MSS SP-67 for "wafer" type.

2.06 SWING CHECK VALVES:

A. Comply with the following standards:

1. Cast-Iron Valves: MSS SP-71
2. Bronze Valves: MSS SP-80
3. Steel Valves: ANSI B16.34

2.07 WAFER CHECK VALVES:

A. General: Provide wafer style, butterfly type, spring actuated check valves designed to be installed with gaskets between 2 standard Class 125 flanges.

2.08 LIFT CHECK VALVES:

A. Conform to FCI 74-1 for design, rating and testing.

2.09 VALVE FEATURES:

A. General: Provide valves with features indicated and, where not otherwise indicated, provide proper valve features as determined by Installer for installation requirements. Comply with ASME B31.9 for building services piping, and ASME B31.1 for power piping.

B. Valve Stems: Valve stems shall extend out past the thickness of the pipe insulation.

C. Bypass: Comply with MSS SP-45, and except as otherwise indicated, provide manufacturer's standard bypass piping and valving.

D. Drain: Comply with MSS SP-45 and provide threaded pipe plugs.

E. Flanged: Valve flanges complying with ANSI B16.5, (steel), or ANSI B16.24 (bronze).

- F. Threaded: Valve ends complying with ANSI B2.1.
- G. Butt-Welding: Valve ends complying with ANSI B16.25.
- H. Socket-Welding: Valve ends complying with ANSI B16.11.
- I. Solder-Joint: Valve ends complying with ANSI B16.18.
- J. Flangeless: Valve bodies manufactured to fit between flanges complying with ANSI B16.5 (steel), or ANSI B16.24 (bronze).
- K. Pressure Ratings: Unless indicated otherwise, valve pressure ratings shall be as follows:
 - 1. Water System: Class 150 for bronze valves, Class 125 for iron valves.
- L. NOTE: All piping valves, fittings, and specialties furnished under this contract shall be as required for the installation of 150 psi boilers operating between 125 psi and 150 psi SWP.

PART 3 - EXECUTION

3.01 INSTALLATION:

- A. General: Except as otherwise indicated, comply with the following requirements:
 - 1. Install valves where required for proper operation of piping and equipment, including valves in branch lines to isolate sections of piping. Locate valves so as to be accessible and so that separate support can be provided when necessary.
 - 2. Install valves with stems pointed up, in vertical position where possible, but in no case with stems pointed downward from horizontal plane unless unavoidable. Install valve drains with hose-end adapter for each valve that must be installed with stem below horizontal plane.
- B. Insulation: Where insulation is indicated, install extended- stem valves, arranged in proper manner to receive insulation.
- C. Mechanical Actuators: Install mechanical actuators with chain operators where indicated. Extend chains to about 5' above floor and hook to clips to clear aisle passage.
- D. Selection of Valve Ends (Pipe Connections): Except as otherwise indicated, select and install valves with the following ends or types of pipe/tube connections:
 - 1. Tube Size 2" and Smaller: Soldered-joint valves.
 - 2. Pipe Size 2" and Smaller: Threaded valves.
 - 3. Pipe Size 2-1/2" and Larger: Flanged valves.
- E. Valve Stems: Select and install valves with outside screw and yoke stems, except provide inside screw non-rising stem valves where headroom prevents full opening of OS&Y valves.
- F. Non Metallic Disc: Shall not be used, except where indicated.
- G. Renewable Seats: Select and install valves with renewable seats, except where otherwise indicated.
- H. Fluid Control: Except as otherwise indicated, install gate and butterfly valves to comply with ANSI B31.9. Where throttling is indicated or recognized as principal reason for valve, install butterfly valves.
- I. Installation of Check Valves:

1. Swing Check Valves: Install in horizontal position with hinge pin horizontally perpendicular to center line of pipe. Install for proper direction of flow.
2. Wafer Check Valves: Install between two flanges in horizontal or vertical position, position for proper direction of flow.
3. Lift Check Valves: Install in piping line with stem vertically upward, position for proper direction of flow.

3.02 GATE VALVES:

- A. 2" and Smaller: Class 150, Bronze, screw-in bonnet, rising stem, solid wedge, equivalent to Stockham B-100 for threaded ends or Stockham B-108 for solder ends. Milwaukee 148, Milwaukee 1149 or Grinnell 3010, Grinnell 3010-SJ, respectively, or Hammond IB640.
- B. 2-1/2" and Larger: Class 125, flanged ends, iron body, bolted bonnet, solid wedge, bronze mounted, OS&Y rising stem, equivalent to Stockham G-623, Milwaukee F-2885, Grinnell 6020, or Hammond IR 1140.

3.04 GLOBE VALVES:

- A. 2" and Smaller: Class 150, Bronze body, screw-in bonnet, integral seat, renewable disc, equivalent to Jenkins 746 for threaded ends or Jenkins 1200 for solder ends, Hammond IB440, Hammond IB423, or Milwaukee 502, Milwaukee 1590, respectively.
- B. 2-1/2" and Larger: Class 125, flanged ends, iron body, bolted bonnet, renewable seat and disc, bronze mounted, equivalent to Jenkins 613, Hamond IR 116 or Milwaukee F-2981.

3.05 DRAIN VALVES:

- A. Bronze body, screw-in bonnet, rising stem, composition disc, 3/4" hose outlet, equivalent to NIBCO 73 for threaded ends or NIBCO 72 for solder ends, Hammond 712, or Watts BD 4F.

3.06 PLUG VALVES:

- A. 2" and Smaller: 150 psi, bronze body, straightaway pattern, square head, threaded ends, equivalent to Lunkenheimer 454, Fairbank, or Jenkins.
- B. 2-1/2" and Larger: 175 psi, lubricated plug type, semi-steel body, single gland, wrench operated, flanged ends, equivalent to Powell 2201, Fairbank, or Jenkins.

3.07 BALL VALVES:

- A. 3" and Smaller: 150 psi WSP, 400 PSI WOG, MSS SP-110 bronze body, full port, bronze trim, TFE seats and seals. Valves shall be CONBRACO "Apollo" series, Nibco S-580, Hammond 8211, or Milwaukee AA-250.

3.08 BUTTERFLY VALVES:

- A. Butterfly Valves shall be full-tapped lug design suitable for dead-end service. Valves through 6" shall have infinite position handles equipped with adjustable memory stops. Valves for working pressure up to 150 psi and 275 F shall have cast iron body, ductile iron or aluminum bronze discs, stainless steel shaft, and elastomeric seats and o-rings. Valves for working pressure above 150 psi shall have carbon steel body and disc, stainless steel stem, reinforced TFE pressure actuated seat with backing ring, and stuffing box with elastomeric packing, follower, and gland. Valves 12" and smaller shall be lug type reinforced with resilient EPDM seat Stockham LG-711-BS3-E, or equivalent to Hammond 621102, or Nibco NL-C1007-3. Valves 14 inches and larger shall be lug type reinforced with resilient EPDM seat with gear operator. Valve shall be Stockham LG-721-BS3-E or equivalent to Hammond 621103, or Nibco NL-C1007-5.

3.09 CHECK VALVES:

- A. 2" and Smaller: Class 150, bronze body, horizontal swing, regrind type, Y-pattern, renewable disc, equivalent to Stockham B-319 for threaded ends or Stockham B-309 for solder ends, Milwaukee 509, Milwaukee 1509, Grinnell 3300, Grinnell 3300 SJ, or Hammond IB904, IB912.
- B. 2-1/2" and Larger: Class 175, iron body, bronze mounted, renewable composition disc and bronze seat ring, bolted cover, flanged ends, Stockham G-940, or equivalent by Milwaukee, Grinnell, or Hammond.

3.10 WAFER CHECK VALVES:

- A. All Sizes: Cast-iron body, aluminum bronze or plated iron plates, stainless steel stem, Buna-N seat, stainless steel springs, equivalent to Stockham WG-970, Nibco W-910 or Hammond IR9253.

3.11 LIFT CHECK VALVES:

- A. 2" and Smaller: Class 250, Bronze body, lift type, spring loaded, renewable disc, threaded ends, equivalent to Jenkins 655A, Hammond 943, or Nibco T-480.

END OF SECTION 23 05 23

SUPPORTS, ANCHORS AND VIBRATION ISOLATION

PART 1 - GENERAL

1.01 RELATED DOCUMENTS:

- A. Drawings, Standard General Conditions of the Construction Contract, including Supplementary General Conditions, Division-01 Specification sections, and other Division 23 specification sections apply to work of this section.

1.02 QUALITY ASSURANCE:

A. Codes and Standards:

1. Code Compliance: Comply with applicable codes pertaining to product materials and installation of supports and anchors.
2. UL and FM Compliance: Provide products which are UL-listed and FM approved where required.
3. Manufacturers Standardization Society of the Valve and Fittings Industry, Inc. (MSS) Standard Compliance:
 - a. Provide pipe hangers and supports of which materials, design, and manufacture comply with MSS SP-58.
 - b. Select and apply pipe hangers and supports, complying with MSS SP-69.
 - c. Fabricate and install pipe hangers and supports, complying with MSS SP-89.
 - d. Terminology used in this section is defined in MSS SP-90.
 - e. Acceptable Manufacturers: Vibration Mountings and Controls, Inc., Grinnell, Modern, or approved equal.

1.03 SUBMITTALS:

- A. Manufacturer's Data: Submit manufacturer's technical product data, including installation instructions for each type of support and anchor.

PART 2 - PRODUCTS

2.01 HORIZONTAL-PIPING HANGERS AND SUPPORTS:

- A. General: Except as otherwise indicated, provide factory- fabricated horizontal-piping hangers and supports complying with MSS SP-58, of one of the following MSS types listed, selected by Installer to suit horizontal-piping systems, in accordance with MSS SP-69 and manufacturer's published product information. Use only one type by one manufacturer for each piping service. Select size of hangers and supports to exactly fit pipe size for bare piping, and to exactly fit around piping insulation with saddle or shield for insulated piping. Provide copper-plated hangers and supports for copper-piping systems.
- B. Adjustable Steel Clevis Hangers: MSS Type 1.
- C. Yoke Type Pipe Clamps: MSS Type 2.
- D. Steel Double Bolt Pipe Clamps: MSS Type 3.
- E. Steel Pipe Clamps: MSS Type 4.
- F. Adjustable Swivel Pipe Rings: MSS Type 6.

- G. Adjustable Steel Band Hangers: MSS Type 7.
- H. Adjustable Band Hangers: MSS Type 9.
- I. Adjustable Swivel Rings, Band Type: MSS Type 10.
- J. Split Pipe Rings: MSS Type 11.
- K. Extension Split Pipe Clamps: MSS Type 12.
- L. U-Bolts: MSS Type 24.
- M. Clips: MSS Type 26.
- N. Pipe Slides and Slide Plates: MSS Type 35, including one of the following plate types:
 - 1. Plate: Unguided type.
 - 2. Plate: Guided type.
 - 3. Plate: Hold-down clamp type.
- O. Pipe Saddle Supports: MSS Type 36, including steel pipe base- support and cast-iron floor flange.
- P. Pipe Stanchion Saddles: MSS Type 37, including steel pipe base support and cast-iron floor flange.
- Q. Adjustable Pipe Saddle Supports: MSS Type 38, including steel pipe base support and cast-iron floor flange.
- R. Single Pipe Rolls: MSS Type 41.
- S. Adjustable Roller Hangers: MSS Type 43.
- T. Pipe Roll Stands: MSS Type 44.
- U. Adjustable Pipe Roll Stands: MSS Type 46.

2.02 VERTICAL-PIPING CLAMPS:

- A. General: Except as otherwise indicated, provide factory- fabricated vertical-piping clamps complying with MSS SP-58, of one of the following types listed, selected by Installer to suit vertical piping systems, in accordance with MSS SP-69 and manufacturer's published product information. Select size of vertical piping clamps to exactly fit pipe size of bare pipe. Provide copper-plated clamps for copper-piping systems.
- B. Two-Bolt Riser Clamps: MSS Type 8.
- C. Four-Bolt Riser Clamps: MSS Type 42.

2.03 HANGER-RODS AND ATTACHMENTS:

- A. General: Except as otherwise indicated, provide factory- fabricated hanger-rod attachments complying with MSS SP-58, of one of the following MSS types listed, selected by Installer to suit horizontal-piping hangers and building attachments, in accordance with MSS SP-69 and manufacturer's published product information. Use only one type by one manufacturer for each piping service. Select size of hanger-rod attachments to suit hanger rods. Provide galvanized steel hanger rods. Provide copper-plated hanger-rod attachments for copper-piping systems.
- B. Steel Turnbuckles: MSS Type 13.
- C. Swivel Turnbuckles: MSS Type 15.

D. Malleable Iron Sockets: MSS Type 16.

2.04 BUILDING ATTACHMENTS:

A. General: Except as otherwise indicated, provide factory-fabricated building attachments complying with MSS SP-58, of one of the following MSS types listed, selected by Installer to suit building substrate conditions, in accordance with MSS SP-69 and manufacturer's published product information. Select size of building attachments to suit hanger rods. Provide copper-plated building attachments for copper-piping systems.

B. Concrete Inserts: MSS Type 18.

C. Channel Clamps: MSS Type 20.

D. Welded Beam Attachments: MSS Type 22.

E. C-Clamps: MSS Type 23.

2.05 SADDLES AND SHIELDS:

A. General: Except as otherwise indicated, provide saddles and shields under piping hangers and supports, factory-fabricated, for all insulated piping. Size saddles and shields for exact fit to mate with pipe insulation.

B. Protection Shields: MSS Type 40; of length recommended by manufacturer to prevent crushing of insulation.

2.06 ROOF CURBS AND PENETRATIONS: (Not Used)

A. Prefabricated roof curbs for penetrations shall be provided by this Division. The curbs shall be installed by the general contractor.

2.07 MISCELLANEOUS MATERIALS:

A. Metal Framing: Provide products complying with NEMA STD ML 1.

B. Steel Plates, Shapes and Bars: Provide products complying with ASTM A 36.

C. Heavy-Duty Steel Trapezes: Fabricate from steel shapes selected for loads required; weld steel in accordance with AWS standards.

2.08 VIBRATION ISOLATION:

A. General: Equipment shall be isolated from the structure by means of resilient vibration and noise isolating supports. Supports shall be such that vibration is isolated and expansion and contraction is accommodated without creating excessive stresses in piping or equipment connections.

1. All isolators shall be designed or treated for resistance to corrosion. Steel components shall be PVC coated, or phosphated and painted with industrial grade enamel. All nuts, bolts and washers shall be zinc-electroplated. Structural steel bases shall be thoroughly cleaned of welding slag and primed with zinc chromate or metal etching primer. A finish coat of industrial enamel shall be applied over the primer. All isolators exposed to the weather shall have steel parts PVC coated, hot-dipped galvanized or zinc-electroplated plus coating of neoprene or bitumastic paint. Aluminum components for outdoor installation shall be etched and painted with industrial grade enamel. Nuts, bolts and washers may be zinc-electroplated.
2. Isolators shall be installed in such a manner that loaded deflections are compensated for initially.

B. Vibration bases and/or isolators shall be provided for all motors and motor-driven equipment, whether indicated on the drawings or not.

- C. Isolator Elements: Steel springs shall be open or housed type as specified with static deflection required and the capability of 30% overtravel before becoming solid. Springs shall be designed for lateral stability with a stiffness ratio of 1 except where greater horizontal thrust requires greater horizontal stiffness.
1. Elastomers shall be rubber, neoprene, Buna N, silicone or other material to meet specific service conditions and shall be molded in the range of 30 to 60 durometer. Material shall be of color-coded stock for easy identification of rated load capacity.
 2. Precompressed fiber glass shall consist of a high-density matrix of molded glass fiber encased in a waterproof neoprene jacket resistant to oil, acids and fungus and color coded for easy identification of rated load capacity.
- D. Isolator Types: Isolators shall be applied in accordance with the "types", as follows, where Type I isolators shall be utilized for centrifugal refrigeration machines installed on or below grade; Type II isolators shall be utilized with mounted equipment of 3 HP or less (unless otherwise specified); Type III isolators shall be utilized with mounted equipment of 5 HP or larger (unless otherwise specified); and Type IV isolators shall be utilized for all suspended equipment:
- E. Type I - Pad type mountings consisting of any one of the following constructions:
1. Two layers of ribbed or waffled neoprene pads bonded to a 16-gauge galvanized steel separator plate. Bolting not required. Pads shall be sized for approximately 20 to 40 psi load, or a deflection of 0.12 inch to 0.16 inch.
 2. Precompressed fiberglass properly sized for 5 to 60 psi loading depending on density with steel plates bonded to top of isolator.
 3. Two layers of ribbed or waffled neoprene pads bonded to vibration cork sized for 10 to 60 psi loading.
- F. Type II - Elastomeric mountings having steel baseplate with mounting holes and a threaded insert at top of the mounting for attaching equipment. All metal parts shall be completely embedded in the elastomeric material. Mountings shall be designed for approximately 1/4-inch deflection and loaded so that deflection does not exceed 15% of the free height of the mounting.
- G. Type III - Adjustable, freestanding, open-spring mountings with combination leveling bolt and equipment fastening bolt. Spring (or springs) shall be rigidly attached to mounting baseplate and to the spring compression plate. A neoprene pad having a minimum thickness of 1/4 inch shall be bonded to the baseplate.
- H. Type IV - Spring hangers consisting of a rectangular steel box, elastomeric element, coil spring, spring cups, neoprene impregnated fabric washer, and steel washer. The design shall be such as to prevent metal-to-metal contact between the hanger rod and the top of the hanger box. The elastomeric element shall meet the design requirements for Type II mountings. The hanger box shall be capable of supporting a load of 200% of rated load with- out noticeable deformation or failure.
- I. Vibration Bases - Bases shall incorporate isolators as herein specified and shall be designed with ample rigidity to resist all starting and operating forces without supplemental hold-down devices.
1. Where height-saving brackets for side mounting of isolators and where recessed pockets for recessed mounting of isolators in inertia blocks are specified, the brackets and pockets shall be designed to provide for an operating clearance of 1 inch under the inertia base, and designed so that the isolators can be installed and removed when the operating clearance is 1 inch or less. When used with spring isolators having a deflection of 2-1/2 inches or more, the brackets and pockets shall be equipped with precompression devices to limit exposed bolt length between the top of the isolator and the underneath side of the bracket.
 2. All bases supporting a given piece of equipment shall be arranged for approximately equal spring deflection.
 3. Bases and isolators for equipment installed out-of-doors shall be designed to provide adequate restraint due to normal wind conditions and to withstand wind loads of 30 lbs/sq.ft. applied to any exposed surface of the equipment without failure.

4. All floor mounted equipment shall be provided with concrete housekeeping pads. Pads not otherwise indicated shall be a minimum of 4 inches high.
 5. Vibration bases shall be utilized as follows:
 - a. Base-mounted pumps driven by motors 15 HP or less shall be mounted on 1 layer of ribbed or waffled neoprene pad material on a concrete housekeeping pad.
 - b. Base-mounted pumps (driven by motors greater than 15 HP) shall be mounted on concrete inertia bases, consisting of a perimeter steel pouring form, reinforcing bars welded in place, bolting templates, and height-saving brackets for side mounting of the isolators. The perimeter steel members shall be structural channels having a minimum depth of 1/12 of the longest span, but not less than 6 inches deep. The base shall be sized a minimum overlap of 4 inches around the base of the equipment, and in the case of belt-driven equipment, 4 inches beyond the end of the drive shaft.
- J. Piping Isolation: Flexible connectors in piping at equipment mounted on vibration isolators shall allow for movement between pipe and equipment. Flexible connectors shall have flanged or screwed ends to match pipe size of line. If screwed ends are used, flanges or unions must be installed to allow for removal of units.
1. Rubber Construction: Single sphere neoprene rubber, large change in diameter, consisting of multiple plies of Kevlar tire cord and EPDM, rated at 225 internal pressure, with captive flanged connections. Provide as manufactured by Keflex, Metraflex, Flexicraft, Triflex, Mason Industries, or approved equal.
 2. Stainless Steel Construction and shall be as made by Keflex, Metraflex, Flexicraft, Triflex, Flex Hose Minnesota Flex, or approved equal. Units shall be designed for no less than 125 psi pressure and have a maximum operating temperature of 450 degrees F. Each unit shall be of the proper length to accept the movement involved and be fitted with a braided jacket.
- K. Pipe Guide: Factory fabricated and insulated guide assembly. No metal contact between pipe and guide body. Split construction for easy installation. Insulation vapor barrier sealed. Provide as manufactured by Keflex Mave Series CP, type AG by Amber/Booth, or approved equal by Grinnell, Amtrol, Flex Hose, or Minnesota Flex.

2.09 PIPE EXPANSION PRODUCTS:

- A. Where indicated, provide pipe expansion products as follows:
1. Pipe Expansion Joints. Provide steel expansion joints rated for 150 psi, factory preset for 2" total axial movement, multi-ply bellows construction, internal stainless-steel liner, shrouded, tie rods, with connection for pipe size indicated. Provide units with factory insulated integral pipe guides. Provide KEFLEX model GTI-M-311TR9-020 or equal by Flex Hose or Minnesota Flex.
 2. Flexible Expansion Loop. Provide flexible expansion loops of size and material noted on drawings. Flexible loops shall be designed to impart no thrust loads on the anchors. The loop shall consist of two flexible sections of hose and braid, two 90-degree elbows, and a 180-degree return. Loops shall be installed in a neutral, pre-compressed, or pre-extended condition as required for application. Loops shall have a working pressure of 100 psi.
 3. Loops installed hanging down shall have a drain plug. Loops installed straight up will be fitted with a manual air release valve to purge air from the high point of the loop. Loops installed in any position other than hanging down must have the 180-degree return supported. Install both upstream and downstream from a pipe guide or anchor in accordance with manufacturer's recommendations. Expansion loops shall be as manufactured by Flex Hose Co., Inc., Metraflex Company, or Tru-flex Metal Hose Corp.

PART 3 - EXECUTION

3.01 INSTALLATION OF HANGERS AND SUPPORTS:

- A. General: Install hangers, supports, clamps and attachments to support piping properly from building structure

with maximum loading as shown below. Arrange for grouping of parallel runs of horizontal piping to be supported together on trapeze type hangers where possible. Install supports with maximum spacings complying with MSS SP-69. Where piping of various sizes is to be supported together by trapeze hangers, space hangers for smallest pipe size or install intermediate supports for smaller diameter pipe. Do not use wire or perforated metal to support piping, and do not support piping from other piping.

1. Provide all fascia boards, cleats, brackets, backing in partitions, toggle bolts, expansion shields, screws, clamps and rods, etc., for hanging of all piping and equipment included under this Division.
- B. Hangers and braces shall adequately support the piping system horizontally and vertically and shall allow for expansion and contraction without binding in sleeves or misalignment. Provide for expansion of piping with swing joints and ample sleeves.
- C. Vertical Piping:
1. Supports for vertical piping 1-1/2 inches and smaller from wall with malleable split ring hanger. Nipples cut to fit each case. Two hangers per floor minimum. Use clamps on every floor for pipes 2 inches and larger.
 2. In crawl spaces, support stacks on base fitting placed securely on concrete piers or masonry blocks and with pipe clamps.
- D. Horizontal piping shall be supported with hangers as follows:

STEEL PIPE SIZE	ROD DIAMETER	MAXIMUM SPACING
Up to 1 inch	3/8 inch	7 feet
1-1/4" inches	3/8 inch	8 feet
1-1/2 inches	3/8 inch	9 feet
2 inches	3/8 inch	10 feet
2-1/2 inches	1/2 inch	11 feet
3 inches. & 3-1/2 inches.	1/2 inch	12 feet
4 inches and 5 inches	5/8 inch	14 feet
6 inches	7/8 inch	17 feet
8 inches	7/8 inch	19 feet
10 inches	7/8 inch	20 feet
12 inches	7/8 inch	23 feet

COPPER TUBE SIZE	ROD DIAMETER	MAXIMUM SPACING
1/2 & 3/4 inch	3/8 inch	5 feet
1 inch	3/8 inch	6 feet
1-1/4 inch	3/8 inch	7 feet
1-1/2 inches	3/8 inch	8 feet
2 inches	3/8 inch	8 feet
2-1/2 inches	1/2 inch	9 feet
3 inches & 4 inches	1/2 inch	10 feet

1. Load carrying capacities of threaded steel rod based on allowable stress of 12,000 psi.

ROD SIZE - INCHES:	3/8	1/2	5/8	3/4	7/8	1	1-1/8	1-1/4
ALLOW LOAD - LBS:	610	1130	1810	2710	3770	4960	6230	8000

2. Stagger and distribute hangers on parallel piping to avoid overloading beams or joists. Threaded pipe, chains, wire and perforated straps will not be accepted. No piping shall be supported from ductwork, conduit or other piping.
3. Generally, pipes shall be individually supported. Trapeze hangers may be used where approved. Piping

shall be individually bolted to trapeze with U bolts.

4. Piping Along Wall - From approved wall brackets fastened to wall with Phillips anchors or inserts. Installation - Provide pipe bars, angles, etc. as required. Anchor piping to localize expansion and prevent undue strain on piping and branches. Provide spring type hangers for vibration isolation where shown on plans and as specified in vibration isolation section.
5. Locate hanger not more than 4 feet from elbow or tee on screwed piping. Space hangers on 3 foot center on horizontal piping 1-1/2 inch and smaller exposed at corridor ceilings and less than 8 feet from floor in finished rooms.
6. Support from Concrete Construction - All main piping runs shall be supported from hangers secured to cast-in-place concrete inserts. Branch piping hanger supports may be field drilled using self drilling type expansion shields equal to Phillips concrete fasteners or approved equal. Expansion shields shall not cut or unduly displace reinforcement.
7. Support from Precast Concrete - Use toggle bolts mounted in core sections of precast concrete. Absolutely no ramset or any other power-driven fasteners will be allowed in precast planks.
8. Support from Existing Concrete - Piping may be attached to the structure using power driven fasteners. All fasteners into concrete shall penetrate the slab for a distance equal to 6 to 8 times the diameter of the shank. Power driven fasteners will not be used in concrete encased steel beams.
9. Test drill existing concrete to ensure rebar is not cut or damaged when installing anchors.
10. Support from Structural Steel - Make use of existing steel members for pipe support. Provide additional structural steel members where required to accommodate hangers.
11. Anchors - Anchor piping as shown or required to isolate expansion and prevent pipe strain due to expansion. Anchors shall be separate from other supports.
12. Expansion Joints and Pipe Guides – Install in accordance with manufacturers recommendation. Locate additional guide within recommended distance of the first guide integral to the expansion joint.

- E. Install hangers and supports complete with necessary inserts, bolts, rods, nuts, washers and other accessories. Except as otherwise indicated for exposed continuous pipe runs, install hangers and supports of same type and style as installed for adjacent similar piping.
- F. Prevent electrolysis in support of copper tubing by use of hangers and supports which are copper plated, or by other recognized industry methods.

3.02 PROVISIONS FOR MOVEMENT:

- A. Install hangers and supports to allow controlled movement of piping systems and to permit freedom of movement between pipe anchors, and to facilitate action of expansion joints, expansion loops, expansion bends and similar units.
- B. Load Distribution: Install hangers and supports so that piping live and dead loading and stresses from movement will not be transmitted to connected equipment.

3.03 PIPE EXPANSION:

- A. Provide pipe expansion products to make allowance for expansion and contraction of pipe.

3.04 INSULATED PIPING:

- A. Comply with the following installation requirements.
 1. Clamps: Attach clamps, including spacers (if any), to piping with clamps projecting through insulation; do not exceed pipe stresses allowed by ANSI B31.
 2. Shields: Where low-compressive-strength insulation or vapor barriers are indicated on cold or chilled water piping, install coated protective shields.

3.05 PIPE GUIDES AND ANCHORS:

- A. Provide pipe guides where specifically shown on drawings to accommodate expansion loops and compensators. Factory fabricated and insulated guide assembly. No metal contact between pipe and guide body. Split construction for easy installation. Insulation vapor barrier sealed. Provide as manufactured by Keflex Mave Series CP, type AG by Amber/Booth, or approved equal by Grinnell, Amtrol, Flex Hose, or Minnesota Flex.

3.06 EQUIPMENT SUPPORTS:

- A. Provide concrete housekeeping bases for all floor-mounted equipment furnished as part of the work of Division 23. Unless otherwise noted, size bases to extend minimum of 4" beyond equipment base in any direction; and 4" above finished floor elevation. Construct of reinforced concrete, roughen floor slab beneath base for bond, and provide steel rod anchors between floor and base. Locate anchor bolts using equipment manufacturer's templates. Chamfer top and edge corners.
- B. Provide structural steel Stands to support equipment not floor mounted or hung from structure. Construct of structural steel members or steel pipe and fittings. Provide factory fabricated tank saddles for tanks mounted on steel stands. Provide shop drawings for structural steel stands for Engineer's approval.
- C. Unless noted otherwise provide Concrete Pads for air cooled chiller, floor-mounted air handling units, heat pumps, pumps, condensing units, cooling towers, packaged heat exchangers, etc. installed outdoors per details in drawings. Provide concrete bases and pads where required in compliance with section 23 05 45 of these specifications.

3.07 GALVANIZING:

- A. All hangers, supports, and connections shall be galvanized coated.

END OF SECTION 23 05 29

ELECTRICAL PROVISIONS FOR MECHANICAL WORK

PART 1 - GENERAL

1.01 RELATED DOCUMENTS AND RELATED WORK SPECIFIED ELSEWHERE:

A. Related Documents

1. Drawings, Standard General Conditions of the Construction Contract, including Supplementary General Conditions, Division 01 Specification sections, other Division 23 specification sections, and Division 26 Sections apply to work of this section.

- B. This section is a Division 23 Basic Mechanical section and is a part of each Division 23 section making reference to electrical provisions of Mechanical work specified within.

1.02 DESCRIPTION OF WORK

- A. Extent of electrical provisions to be provided as mechanical work is indicated in other Division 23 sections, on drawings, and as further specified in this section.

- B. All work on this project will be done through a single prime contract. All power and control wiring and other electrical work shown is the responsibility of the prime contractor. These include but are not necessarily limited to the following:

1. Motors for mechanical equipment.
2. Starters for motors of mechanical equipment whether or not starter is specifically indicated to be furnished with the mechanical equipment. Unless otherwise noted, the mechanical contractor shall provide all motor starters, and combination starters/disconnects required for mechanical equipment. Motors being equipped with adjustable speed drives (ASD's) will not require starters. The mechanical contractor shall provide the ASD's.
3. All electrical equipment and devices (panels, disconnects, circuit breakers, etc.).
4. All interlock and control wiring required for sequence of operation of mechanical devices provided for mechanical systems.
5. All power wiring for mechanical equipment and all power and low voltage wiring for the DDC controls.
6. Any power wiring required for mechanical equipment not specifically shown on electrical drawings or specified in Division 26.
7. Duct smoke detectors, if provided per NFPA 90A requirements, shall be furnished and wired by Division 26, installed by Division 23. Fire alarm AHU shut down circuits shall be wired from the fire alarm control panel to a termination point, adjacent to the AHU control, under Division 26. AHU control wiring from the termination point to the equipment shall be under Division 23.

- C. Refer to other Division-23 sections for specific individual mechanical equipment electrical requirements.

- D. Refer to Division-26 sections for any electrical equipment not included in this section and for materials and methods of other electrical components.

1.03 QUALITY ASSURANCE

- A. Coordination with Electrical Work: Wherever possible, match elements of electrical provisions of mechanical work with similar elements of electrical work specified in Division 26 sections. Comply with applicable requirements of Division 26 sections for electrical work of this section which is not otherwise specified.

- B. Standards: For electrical equipment and products, comply with applicable NEMA standards, and refer to

NEMA standards for definitions of terminology herein. Comply with National Electrical Code (NFPA 70) for workmanship and installation requirements. Electrical work shall be done in accordance with Codes listed and also requirements of Division 26.

1.04 SUBMITTALS

- A. Listing, Motors of Mechanical Work: Concurrently with submittal of mechanical products listing (Basic Mechanical requirements), submit separate listing showing rating, power characteristics, application (connected equipment), and general location of every motor to be provided with mechanical work. Submit updated information promptly when and if initial data is revised.
- B. Include in listing of motors, notation of whether motor starter is furnished or installed integrally with motor or equipment containing motor.
- C. Product Data of Motor Control Equipment
- D. Product Data of Motor Safety Disconnect Equipment.
- E. Product Data of ASD Cables

PART 2 - PRODUCTS

2.01 MOTORS

- A. Manufacturer: Except where item of mechanical equipment (which otherwise complies with requirements) must be integrally equipped with motor produced by another manufacturer, provide motors for mechanical equipment manufactured by one of the following:
 - 1. Baldor Electric Co.
 - 2. General Electric Co.
 - 3. Reliance Electric Co.
 - 4. U.S. Electric Motor Co.
- B. Motor Characteristics: Except where more stringent requirements are indicated, and except where required mechanical equipment cannot be obtained with fully complying motor, comply with the following requirements for motors of mechanical work:
 - 1. Temperature Rating: Rated for 40 deg.C environment with maximum 50 deg.C temperature rise for continuous duty at full load. Insulation shall be Class F.
 - 2. Starting Capability: Provide each motor capable of making starts as frequently as necessary by automatic control system, and not less than 5 starts per hour for manually controlled motors.
- C. Phases and Current Characteristics: Unless otherwise noted, provide squirrel-cage induction polyphase motors for 1/2 hp and larger, and provide capacitor-start single-phase motors for 1/3 hp and smaller, except 1/6 hp and smaller may, at equipment manufacturer's option, be split-phase type. Coordinate current characteristics with power specified in Division 26 sections, and with individual equipment requirements specified in other Division 23 requirements. For 2-speed motors provide 2 separate windings on polyphase motors. Unless otherwise noted all polyphase motors shall be suitable for 240 volt, 3 phase, 60 Hz service.
- D. Service Factor: 1.15 for polyphase motors and 1.35 for single-phase motors.
- E. Motor Construction: Provide general purpose, continuous duty motors, Design "B" except "C" where required for high starting torque. For motors controlled by variable speed drives, provide inverter duty motors that comply with NEMA MG1-Part 31 Definite Purpose Inverter-Fed Polyphase Motors.
- F. Frames: NEMA No. 56 or Type T(unless otherwise noted)

- G. Bearings: Ball or roller bearings with inner and outer shaft seals, regreasable except permanently sealed where motor is normally inaccessible for regular maintenance.
- H. Motor shaft grounding: Provide low impedance shaft grounding rings and brushes for ASD controlled motors as a path for induced shaft currents. This applies to induction motors, not to permanent magnet motors.
- I. Where belt drives and other drives produce lateral or axial thrust, in motor, provide bearings designed to resist thrust loading. Refer to individual sections of Division 23 for fractional-hp light-duty motors where sleeve-type bearings are permitted.
- J. Enclosure Type: Except as otherwise indicated, provide TEFC motors. Refer to individual sections of Division 23 for other enclosure requirements.
- K. Overload Protection: Provide built-in thermal overload protection and, where indicated, provide internal sensing device suitable for signaling and stopping motor at starter.
- L. Noise Rating: Provide "Quiet" rating on motors.
- M. Efficiency: All permanently wired motors of 1 HP or more shall have a nominal full load motor efficiency not less than that required by ASHRAE 90.1. Unless otherwise specified, provide premium efficiency motors.
- N. Name Plate: Provide metal nameplate on each motor, indicating full identification of manufacturer, ratings, characteristics, construction, special features and similar information.

2.02 EQUIPMENT FABRICATION

- A. General: Fabricate mechanical equipment for secure mounting of motors and other electrical items included in work. Provide either permanent alignment of motors with equipment, or adjustable mountings as applicable for belt drives, gear drives, special couplings and similar indirect coupling of equipment. Provide safe, secure, durable, and OSHA compliant removable guards for motor drives, arranged for lubrication and similar running-maintenance without removal of guards.

2.03 MOTOR STARTERS

- A. Manufacturers: Subject to compliance with requirements, provide motor starters of one of the following (for each type and rating of motor starter):
 1. Eaton Corp.
 2. General Electric Co.
 3. Square D Co.
 4. Siemens
- B. General: Except as otherwise indicated, provide motor starters and ancillary components which comply with manufacturer's standard materials, design and construction in accordance with published product information, and as required for complete installation.
- C. Type and size of starter shall be as recommended by motor manufacturer and the driven equipment manufacturer for applicable protection and start-up condition.
- D. Motor Starter Characteristics:
 1. Enclosures: NEMA 1, general purpose enclosures with padlock ears, except in wet locations shall be NEMA 3R with conduit hubs, or units in hazardous locations which shall have NEC proper class and division.
 2. Manual switches shall have pilot lights and extra positions for multi-speed motors.
 3. Overload protection: Electronic solid state overload relays with integral phase loss protection.

E. Magnetic Starters:

1. Maintained contact push buttons and pilot lights, properly arranged for single speed or multi-speed operation as indicated.
2. Trip-free thermal overload relays, each phase.
3. Interlocks, pneumatic switches and similar devices as required for coordination with control requirements of mechanical equipment. Multi-Speed starters shall be provided with integral time delay transition between "FAST" and "SLOW" speeds.
4. Built-in control circuit transformer, fused on line and load side to match coil voltages of controls elements. Train wiring to maintain separation of line, load and controls voltage conductors.
5. Externally operated manual reset.
6. Under-voltage release or protection.

F. Motor Connections: Liquid-tight flexible conduit not to exceed 4'-0" in length, except where plug-in electrical cords are specifically indicated.

G. Combination Non-Reversing Starters: Provide full voltage alternating-current combination non-reversing starters, consisting of starter and disconnect switch mounted in common enclosure, of types, sizes, ratings, and NEMA sizes as required. Equip starters with electrical interlocks for interfacing with other starters. Equip starters with block type manual reset overload relays and with circuit breakers or non-fusible disconnect switches.

H. Provide ground bus bars or double-barrel ground lugs to maintain low impedance ground path from motor.

I. Provide operating handle for disconnect mechanism with indication and control of switch position, with enclosure door either opened or closed, and capable of being padlocked in OFF position. Construct and mount starters and disconnect switches in single NEMA Type 1 enclosure: coat with manufacturer's standard color finish.

J. AC Fractional HP Manual Starters: Provide single-phase fractional HP manual motor starters, of sizes and ratings required. Equip with manually operated quick-make, quick-break toggle mechanisms; and with one-piece melting alloy type thermal units. Starter to become inoperative when thermal unit is removed. Provide starters with double break silver alloy contacts, visible from both sides of starter; green pilot lights and switch capable of being padlocked OFF. Enclose starter unit in NEMA Type 1 general purpose enclosure suitable for flush mounting; coat with manufacturer's standard color finish.

2.04 WIRING

A. Wiring shall be 600 volt rated thermoplastic insulated listed for the use and conditions they are installed in.

B. Low voltage wiring shall be AWG no. 16 or larger as needed to accommodate voltage drop, color coded wire or cable. Line voltage wiring shall be not smaller than no. 12 AWG. All wire shall be run in rigid conduit with outlet boxes and fittings in a manner specified in the electrical specifications. All ground wire shall be insulated green run inside raceway system with current carrying conductors. All wire shall be pulled to every pump, disconnect, starter motor etc. Conduit shall not be used as ground.

C. All raceway, wiring and electrical installations shall comply with Division 26.

2.05 DISCONNECTS

A. Non Fused.

1. Wall mounted, standard duty, single throw in NEMA-1 enclosure or NEMA 3R enclosure, weatherproof for exterior locations. Single pole or three pole as required with insulated solid neutral double-barrel lug/bar and bonded ground double-barrel lug/bar. External handle lockable in the open position. Disconnect switches shall be provided wherever the code requires local disconnecting means.
2. Make - Square D, EATON, General Electric or Siemens.

B. Fused Disconnect Switches

1. Fused disconnect switches shall be used only where fuse ratings are established on equipment nameplates in lieu of MOCP ratings. Use enclosed circuit breakers where possible.
2. Single throw, quick-make, quick-break Number of poles as required by load. NEMA-1 general purpose enclosure indoors in dry locations, NEMA 3R weatherproof enclosure outside. Standard fuse clips, lockable in open position. Rating 250 or 600 VAC as required.
3. Accessories: Provide a shield and a strap for removing the fuse.
4. Make - Square D, EATON, General Electric or Siemens.

2.06 MOLDED CASE CIRCUIT BREAKERS (MCCB)

A. Manufacturers: Subject to compliance with requirements, provide MCCB's of one of the following:

1. EATON Corp.
2. General Electric
3. Siemens
4. Square D

B. General: MCCB's shall be industrial grade (bolt-on) with ratings and special features as scheduled on drawings. Trips shall be thermal magnetic with inverse time delay and instantaneous time-current characteristics. 225 ampere frame and larger MCCB's shall have interchangeable trips and adjustable magnetic feature. MCCB's used outdoors shall have ambient compensating trips. MCCB's used for switching lights shall be rated for switching duty and shall be so labeled. MCCB's used for overcurrent protection for HVAC equipment shall be rated "HACR" type and shall be so labeled. MCCB's to be installed in existing panelboards shall be of the same manufacturer as the panelboard and listed for the use.

C. Ganged use of single-pole breakers for multi-pole applications is not acceptable.

2.07 ENCLOSED CIRCUIT BREAKERS (ECB)

A. Manufacturers: Subject to compliance with requirements, provide ECB's of one of the following:

1. EATON Corp.
2. General Electric
3. Siemens
4. Square D

B. General: ECB's shall be used where possible for motor and mechanical equipment disconnect switches. Fused disconnect switches shall only be used where fuse ratings and no MOCP ratings are shown on the nameplate.

C. ECB ratings shall be per NEC and manufacturer's documentation, in that order where conflicts may exist.

D. Ganged use of single-pole breakers for multi-pole applications is not acceptable.

2.08 ADJUSTABLE SPEED DRIVES

A. Refer to Section 230571 Adjustable Speed Drives.

B. Wiring between Adjustable speed drives and motors shall be ASD rated premanufactured cable with twisted motor leads in raceway to reduce EMF.

PART 3 - EXECUTION

3.01 INSTALLATION

- A. Install motors on motor mounting systems in accordance with motor manufacturer's instructions, securely anchored to resist torque, drive thrusts, and other external forces inherent in mechanical work. Secure sheaves and other drive units to motor shafts with keys and Allen set screws, except motors of 1/3 hp and less may be secured with Allen set screws on flat surface of shaft. Unless otherwise indicated, set motor shafts parallel with machine shafts.
- B. Install motor starters, in accordance with equipment manufacturer's written instructions and with recognized industry practices; complying with applicable requirements of NEC, UL and NEMA standards, to ensure that products fulfill requirements.
- C. Coordinate with other work including motor and electrical wiring/cabbling work, as necessary to interface installation of motor starters with other work.
- D. Tighten connectors and terminals, including screws and bolts, in accordance with equipment manufacturer's published torque tightening values for equipment connectors. Where manufacturer's torquing requirements are not indicated, tighten connectors and terminals to comply with tightening torques specified in UL Std 486A.

3.02 ADJUSTING AND CLEANING

- A. Inspect electrical starter's operating mechanisms for malfunctioning and, where necessary, adjust units for free mechanical movement.
- B. Touch-up scratched or marred surfaces to match original finish.

3.03 FIELD QUALITY CONTROL

- A. Subsequent to connecting wires/cables, energize motor starter circuitry and demonstrate functioning of equipment in accordance with requirements; where necessary correct malfunctioning units, phase rotation at the motor to maintain distribution system phase color sequence and then retest to demonstrate compliance.

END OF SECTION 23 05 30

MECHANICAL RELATED WORK

PART 1 - GENERAL

1.01 RELATED DOCUMENTS:

- A. Drawings and Standard General Conditions of the Construction Contract, including Supplementary General Conditions, Division 00 and 01 Specification sections, other Division 23 specification sections, and Division 26 specifications apply to work of this section.

1.02 DESCRIPTION OF WORK:

- A. Types of mechanical related work specified in this section include the following:
 1. Concrete for Mechanical Work

1.03 QUALITY ASSURANCE

- A. Concrete Work Codes and Standards: Comply with governing regulations and, where not otherwise indicated, comply with the following industry standards, whichever is the most stringent in its application to work in each instance:
 1. ACI 301, "Specifications for Structural Concrete for Buildings".
 2. ACI 318, "Building Code Requirements for Reinforced Concrete".
 3. ACI 347, "Recommended Practice for Concrete Formwork".
 4. ACI 304, "Recommended Practice for Measuring, Mixing, Transporting and Placing Concrete".
 5. Concrete Reinforcing Steel Institute's, "Manual of Standard Practice".
- B. Shop Drawings, Mechanical Concrete Work: Submit shop drawings for structural type concrete work (tanks, vaults, basins, foundations and other supports), showing dimensions of formed shapes of concrete; bending, placement, sizes and spacing of reinforcing steel; location of anchors, isolation units, hangers and similar devices to be integrated with concrete work; and piping penetrations, access openings, inlets and other accessories and work to be accommodated by concrete work.
- C. Laboratory Test Reports, Mechanical Concrete Work: Submit laboratory test reports for concrete work materials, and for tested samples of placed concrete (where required as work of this section)
- D. Set-Control Additives shall not be used without approval by the Engineer.
- E. Prohibited Admixtures: Calcium Chloride or admixtures containing more than 0.1% chloride ions are not permitted.

PART 2 - PRODUCT

2.01 MATERIALS OF CONCRETE WORK:

- A. Form Materials and Construction:
 1. Forms for Exposed Concrete: Plywood, smooth metal or other smooth panel type material; sized for minimum joint exposure and reinforced to prevent visible deflections resulting from pressure of placed concrete; sufficiently heavy for construction to prevent leakage which would be harmful to either structural or visual quality of concrete.
 - a. Plywood: PS-1 "BB (Concrete Form) Plywood", Class I, Exterior Grade, mill-oiled and edge sealed.

2. Forms for Unexposed Concrete: Smooth lumber, plywood or other easy-release material; reinforced to prevent excessive deflection or the possibility of failure during placement of concrete; sufficiently heavy for construction to prevent leakage which would be harmful to structural quality of concrete.
3. Exposed-Corner Chamfer Strips: Provide wood, metal, plastic or rubber chamfer strips in forms at exposed external corners of concrete work.
4. Form-Coating Compound: Commercially formulated compound which will prevent bond of concrete to forms. Provide compound recommended by manufacturer for application indicated, and which will not stain concrete or interfere with moisture curing of concrete or subsequent painting of exposed surfaces. Provide environmentally friendly products.

B. Reinforcing Materials:

1. Reinforcing Bars: Except as otherwise indicated, provide ASTM A 615, deformed, Grade 60; sizes as indicated.
2. Steel Wire: ASTM A 82, plain, cold-drawn.
3. Welded Wire Fabric: ASTM A 185; sizes and spacing of wires as indicated; 6" x 6" x No. 10 x No. 10 where not otherwise indicated.
4. Reinforcement Supports: Provide supports for reinforcement including bolsters, chairs, spacers and other devices for spacing, supporting and fastening reinforcing bars and welded wire fabric in place. Provide wire bar type supports complying with CRSI recommendations, unless otherwise indicated.

C. Concrete Materials:

1. Portland Cement: ASTM C 150, Type I, except as otherwise indicated.
2. Aggregates: ASTM C 33, except as otherwise indicated.
3. Water: Clean and free of substances harmful to concrete.

D. Air-Entraining Admixture: ASTM C 260.

E. Miscellaneous Materials:

1. Waterstops: Provide either rubber or PVC waterstops of types and sizes indicated or if not otherwise indicated, provide types and sizes recommended by manufacturer for application indicated. Comply with Corps of Engineers CRD-C513 or CRD-C572 (as applicable).

2.02 DESIGN AND PROPORTIONING OF MIXES:

A. General: Design mechanical work concrete as follows, for each 28-day compressive strength class:

1. 4000 psi Class: 565 lbs. of cement per cu. yd. (6.0 sacks), and 0.35 water/cement ratio.
2. 3000 psi Class: 500 lbs. of cement per cu. yd. (5.25 sacks), and 0.46 water/cement ratio.
3. 2500 psi Class: 450 lbs. of cement per cu. yd. (4.75 sacks), and 0.54 water/cement ratio.
4. Backfill Class (Lean Concrete): 375 lbs. of cement per cu. yd., (4.0 sacks), and 0.60 water/cement ratio.
5. Rough Grouting Class: 565 lbs. of cement per cu. yd. (6.0 sacks), and 0.60 water/cement ratio.

B. Slump Limitations: Limit water content in design mixes to produce the following slumps at point of placement (but do not exceed specified water/cement ratios). Concrete containing high-range water-reducing admixture may have slump limit up to 8".

1. Reinforced Structural Concrete: For concrete which is reinforced (with more than shrinkage crack protection), or in strength class of 3000 psi and above, limit slump to range of 1" to 3".
2. Plain Concrete: For concrete which is not reinforced or reinforced only for shrinkage crack protection, and in strength class below 3000 psi, limit slump to range of 2" to 5".
3. Rough Grout Concrete: Limit slump to range of 3" to 7".
4. Backfill Concrete: Limit slump to 5".

C. Mix for Patching: Where mechanical work requires patching of exposed concrete work which has been cut to

accommodate mechanical work, provide concrete patching mix which is identical with mix of work being patched (same cement, aggregates, admixtures and proportioning).

2.03 CONCRETE MIXING:

- A. Job-Site Mixing: Job-site mixing of concrete is permissible only for incidental concrete work. Mix materials for concrete in drum-type batch machine mixer. For mixers of 1.0 cu. yd., or smaller capacity, continue mixing at least 1-1/2 minutes, but not more than 5 minutes after all ingredients are in mixer, before any part of batch is released. For mixers of capacity larger than 1.0 cu. yd., increase mixing time by 15 seconds for each additional cu. yd., or fraction thereof.
- B. Ready-Mix Concrete: Comply with requirements of ASTM C 94, except as otherwise indicated. Addition of water to batch will not be permitted. During hot weather, or under conditions contributing to rapid setting of concrete, mix each load for shorter period of time than specified in ASTM C 94. When air temperature is between 85 and 90 deg.F (29.4 and 32.2 deg.C), reduce mixing and delivery time from 90 minutes to 75 minutes, and when air temperature is above 90 deg.F (32.2 deg.C), reduce mixing and delivery time to 60 minutes.

PART 3 - EXECUTION

3.01 INSTALLATION OF CONCRETE WORK:

- A. Formwork:
 - 1. General: Design, construct and maintain formwork to support vertical and lateral loads including pressure of cast-in-place concrete. Construct formwork so that formed concrete will be required size and shape and in required location. Construct with joints which will not leak cement paste. Form sides and bottoms of concrete work, except where clearly indicated to be cast directly in excavation or against other construction, or on grade or prepared subgrade. Design and construct forms for easy removal without damage to concrete and other work. Install chamfer strips at external corners of exposed concrete work. Install formwork in full compliance with OSHA safety standards.
 - 2. Placing Reinforcement:
 - 3. General: Comply with requirements and recommendations of specified standards, including "Placing Reinforcing Bars" by CRSI. Place bars where indicated and support to prevent displacement during concrete placement, using appropriate reinforcement supports, properly spaced and wire tied to reinforcing bars.
 - 4. Placing Concrete:
 - 5. Strength-Class Applications: Comply with compressive-strength-classes shown on drawings for each unit of mechanical concrete work or, if not shown, comply with the following general application requirements.
 - a. Plain Concrete Encasement: Provide 2500 PSI class.
 - b. Reinforced Concrete Encasement: Provide 3000 PSI class.
 - c. Underground Structural Concrete: Provide 3000 PSI class.
 - d. Tanks and Vaults: Provide 4000 PSI class.
 - e. Block-Type Foundations: Where least dimension is not less than 0.2 x largest dimension, provide 3000 PSI class.
 - f. Beam-Type Foundations: Where least dimension is less than 0.2 x largest dimension, provide 4000 PSI class.
 - g. Miscellaneous Supported Work: Provide 3000 PSI class for curbs, pads, inertia blocks and similar supported work.
 - h. Concrete Fill: Provide 2500 PSI class for filling structural steel foundation frames and for filling similar large-volume units.
 - i. Concrete Grout: Provide rough grouting class for filling voids to be grouted which are too small to be filled effectively with 2500 PSI class concrete.
 - j. Patching General Concrete Work: Match concrete being patched.

6. Deposit concrete continuously or in layers of thickness which will result in no concrete being placed on concrete which has hardened sufficiently to cause formation of seams or planes of weakness within section. If section cannot be placed continuously, provide construction joints. Deposit concrete as nearly as practicable in its final location, so as to avoid segregation due to rehandling or flowing.
7. Consolidate placed concrete by mechanical vibrating equipment supplemented by hand-spading, rodding or tamping. Use equipment and procedures complying with recommended practices of ACI 309; eliminate voids in work.
8. Bring horizontal surfaces to correct level with straightedge and strike off. Use bull floats or darbies to smooth surface, free of humps and hollows.
9. Cold Weather Placement: Comply with ACI 306. Do not use frozen materials or materials containing ice and snow. Do not place concrete on frozen subgrade or on subgrade containing frozen materials. When air temperature has fallen or is expected to fall below 40 deg.F (4.4 deg.C), heat water and aggregates uniformly before mixing, as required to obtain concrete mixture temperature of not less than 50 deg.F (10 deg.C), and not more than 80 deg.F (26.7 deg.C), at time of placement. Protect concrete work from physical damage and reduced strength resulting from frost, freezing actions, or low temperatures.
10. Hot Weather Placement: Comply with ACI 305 when hot weather conditions could impair work. Maintain concrete temperature below 90 deg.F (32.2 deg.C) at time of placement, by cooling ingredients. Mixing water may be chilled, or chopped ice may be used to control concrete temperature, provided water equivalent of ice is included in calculating compliance with water/cement ratio limitations. Cover reinforcing steel with water-soaked burlap as necessary to ensure that steel temperature will not exceed ambient air temperature immediately before embedment in concrete.
11. Finishing Horizontal Surfaces: Float and trowel horizontal (top) surfaces to level, smooth, uniform textured, dense finish, where surface is to remain exposed or receive coating, membrane or other thin-set finish. Otherwise, leave struck off surface undisturbed; except scratch surfaces which are to receive concrete or mortar topping or setting bed, by raking with a stiff broom.
12. Curbs: Provide monolithic finish on interior curbs by stripping forms while concrete is still green and steel-troweling surfaces to hard, dense finish with corners, intersections and terminations slightly rounded and coved.

3.02 MISCELLANEOUS CONCRETE WORK:

- A. Concrete Grouting: Grout openings and recesses in and around mechanical work and other work which penetrates or adjoins mechanical concrete work, using rough grouting class of concrete mix. Provide formwork where required, and tamp, screed and trowel surfaces.

END OF SECTION 23 05 45

PART 1 -GENERAL

1.01 RELATED DOCUMENTS AND RELATED WORK SPECIFIED ELSEWHERE:

A. Related Documents

1. Drawings, Standard General Conditions of the Construction Contract, including Supplementary General Conditions, Division 01, other Division 23 specification sections apply to work of this section.

1.02 REFERENCES

- A. NEMA ICS 3.1 - Safety Standards for Construction and Guide for Selection, Installation and Operation of Adjustable Speed Drive Systems.
- B. NEMA 250 - Enclosures for Electrical Equipment (1000 Volts Maximum).
- C. UL and cUL Approved, or CSA Approved.

1.03 SUBMITTALS

- A. Submit Manufacturer's technical product data and installation instructions.
- B. Shop drawings shall include; wiring diagrams, front and side views of enclosures, overall dimensions, conduit entrance locations and requirements, nameplate legends, and enclosure details.
- C. Product Data: Provide data sheets showing; voltage, ratings and size of switching and overcurrent protective devices, short circuit ratings, and weights.
- D. Product Data: Provide data for enclosure. For outdoor installations provide heat dissipation and airflow requirements, specifications for enclosure ventilating fan and heater.
- E. Manufacturer's Installation Instructions: Indicate application conditions and limitations of use stipulated by product testing agency specified under regulatory requirements. Include instructions for storage, handling, protection, examination, preparation, installation, and starting of adjustable speed drive.

1.04 QUALITY ASSURANCE

- A. ASD shall have a minimum MTBF (mean time between failure) rating of 100,000 hours.

1.05 OPERATION AND MAINTENANCE DATA

- A. Submit under provisions of Section 230510.
- B. Include instructions for starting and operating ASD, and describe operating limits, that may result in hazardous or unsafe conditions.

1.06 QUALIFICATIONS

- A. Manufacturer must have a minimum of 10 (ten) years documented experience, specializing in adjustable speed drives.

1.07 DELIVERY, STORAGE, AND HANDLING

- A. Deliver, store, protect and handle products to site, under provisions of Section 230510.
- B. Accept ASD on site in original packing. Inspect for damage.
- C. Store in a clean, dry space. Maintain factory wrapping, or provide an additional heavy canvas or heavy plastic cover, to protect units from dirt, water, construction debris, and traffic.
- D. Handle carefully, in accordance with manufacturer's written instructions, to avoid damage to components, enclosure, and finish.

1.08 WARRANTY

- A. Provide ASD warranty, for two years from date of final acceptance. Warranty shall include parts, labor, living expenses, and travel costs. The warranty shall be provided by the ASD manufacturer, not a third party. A written warranty statement shall be provided with submittals.

PART 2– PRODUCTS

2.01 MANUFACTURERS

- A. ASD shall be manufactured by ABB, Danfoss, Franklin Control Systems, Schneider Electric, Square D, Toshiba, Yaskawa America Inc.(Z1000 type),or approved alternate.
- B. Note: These may be referred to on the drawings as ASDs which is short for adjustable speed drives, VSDs which is short for variable speed drives, or VFDs which is short for variable frequency drives. This specification applies to all of these.

2.02 DESCRIPTION

- A. Provide enclosed adjustable speed drives suitable for operating at the current, voltage, and horsepower indicated on the plans. Conform to requirements of NEMA ICS 3.1. Provide NEMA 1 enclosure for indoor environment, and NEMA 3R enclosure for outdoor environment.

2.03 RATINGS

- A. ASD must operate, without fault or failure, when voltage varies plus or minus 10 percent from rating, and frequency varies plus or minus 5 percent from rating.
- B. Enclosure: NEMA / UL TYPE 1 enclosures for indoor installations.NEMA / UL TYPE 3R enclosures for outdoor installations.
- C. Fundamental (Displacement) Power Factor: 0.98 over entire range of operating speed and load.
- D. Operating Ambient Temperature for outdoor applications: -15 degrees C. to 40 degrees C. (5 degrees F. to 104 degrees F.)
- E. Operating Ambient Temperature for indoor applications: -10 degrees C. to 40 degrees C. (14 degrees F. to 104 degrees F.)
- F. Humidity for outdoor applications: to 95% relative humidity.
- G. Humidity for indoor applications: noncondensing to 95% relative humidity.
- H. Altitude: to 3300 feet, higher by derating.

- I. Minimum Efficiency: 96% at half speed; 97% at full speed and name plate motor speed.
- J. Overload capability: 110% of rated F.L.A. (full load amps) for 60 seconds; 150% of rated F.L.A. peak.
- K. The ASD must meet the requirements for Radio Frequency Interference (RFI) above 7 MHz as specified by FCC regulations, part 15, subpart J, Class A devices.
- L. In compliance with IEEE 519, the Total Harmonic Distortion for the ASD shall be no greater than 5%. When the THD is above 5% the supplier of the ASD shall provide line reactors.

2.04 DESIGN

- A. ASD shall employ microprocessor-based inverter logic, isolated from all power circuits.
- B. ASD shall employ a PWM (pulse width modulated) inverter system.
- C. ASD shall have an adjustable carrier frequency.
- D. ASD shall have embedded Building Automation System (BAS) protocols for network communications; BACnet , Modbus/Memobus, Siemens Apogee, Johnson Controls Metasys. These protocols shall be accessible via a RS-422/485 communication port.
- E. ASD shall include two independent analog inputs. One shall be 4-20 ma. The other shall be 0-10 VDC. Either input shall respond to a programmable bias and gain.
- F. ASD shall include a minimum of seven multi-function digital input terminals, capable of being programmed to determine the function on a change of state. These terminals shall include, but not limited to:
 - 1. Remote/Local operation selection
 - 2. Customer Safeties
 - 3. BAS / Damper Interlock
 - 4. Emergency Override
 - 5. Preset Speed
 - 6. PI control enable / disable
- G. ASD shall include two selectable 0-10 VDC or 4-20 mA analog outputs for monitoring, or "speed tracking" the ASD. The analog output signal will be proportional to output frequency, output current, output power, PI (Proportional & Integral control) feedback or DC bus voltage.
- H. ASD shall provide terminals for remote input contacts, to allow starting in the automatic mode.
- I. ASD shall provide 24 Vdc, 150ma transmitter power supply.
- J. ASD shall include at least one external fault input, which shall be programmable, for either a normally open, or a normally closed contact, for connection to freezestats, or similar safety devices.
- K. ASD shall include three programmable form "A" contacts and one fixed "Fault" form "C" contact, capable of being programmed to determine conditions that must be met in order for them to change state. These output relay contacts shall be rated for at least 2A at 120 VAC and shall include, but not limited to:
 - 1. Speed agree detection
 - 2. Damper control
 - 3. Hand / Auto Status
 - 4. No load detection (broken belt alert)
 - 5. Contactor Control for External Bypass

6. Drive Faulted
 7. Serial communication status
- L. ASD shall include a power loss ride thru of 2000 milliseconds (2 seconds).
 - M. ASD shall have DC injection braking capability, to prevent fan “wind milling” at start or stop, adjustable, current limited.
 - N. ASD shall include a front mounted, sealed keypad operator, with an English language illuminated LCD display. The operator will provide complete programming, program copying, operating, monitoring, real time clock and diagnostic capability. Keys provided shall include industry standard commands for Hand, Off, and Auto functions.
 - O. ASD display shall provide readouts of; output frequency in hertz, output voltage in volts, output current in amps, output power in kilowatts, D.C. bus voltage in volts, interface terminal status, and fault codes.
 - P. ASD unit shall include the following meters to estimate use and energy costs:
 1. Elapsed Time Meter
 2. Kilowatt/Hour Meter
 3. Operating Cost Meter.
 - Q. ASD shall be capable of PID (Proportional, Integral, Derivative) logic, to provide closed-loop setpoint control capability, from a remote reference.
 - R. ASD shall include loss of input signal protection, with a speed default to 80 % of the most recent speed.
 - S. ASD shall include electronic thermal overload protection for both the drive and motor, profilable for variable or constant torque.
 - T. ASD shall include the following programming functions:
 1. Critical frequency rejection capability: 3 selectable, adjustable bands.
 2. Auto restart capability: 0 to 10 attempts.(Provide automatic soft restart when power comes back on after a power failure or after a fire alarm shut-down signal has been cleared.)
 3. Stall prevention capability.
 4. "S" curve soft start capability.
 5. "Speed search" capability, in order to start a rotating load.
 6. 15 preset volts per hertz patterns.
 7. One adjustable volts per hertz pattern.
 8. Current limit adjustment capability, from 30 % to 200 % of rated full load current of the ASD.
 9. Anti "wind milling" function capability.
 - U. ASD shall include factory settings for all parameters, and the capability to be reset back to those settings.
 - V. ASD shall include the capability to adjust the following functions, while the ASD is running:
 1. Acceleration adjustment from 0 to 600 seconds.
 2. Deceleration adjustment from 0 to 600 seconds.
 3. A minimum of three different preset speeds.
 4. Analog output gain, to calibrate the signal for the application used.
 - W. ASD shall have built in phase loss protection.

- X. Manual Bypass shall be provided. ASD and bypass components shall be mounted inside a common NEMA 1 enclosure for indoor installation, NEMA 3R for outdoor installation, fully pre-wired, and ready for installation as a single UL listed device. Bypass shall include the following:
 - 1. Input, output, and bypass contactors, to disconnect power to the ASD, when the motor is running in the bypass mode.
 - 2. 115 V.A.C. control transformer, with fused primary.
 - 3. Thermal overload relay, to protect the motor while operating in the bypass mode.
 - 4. Circuit breaker/disconnect switch, with a "through-the-door" handle mechanism.
 - 5. Control and safety circuit terminal strip.
 - 6. "Drive-Off-Bypass" selector switch.
 - 7. Pilot lights for "Power On", "Running On Drive", "Running On Bypass" and "Fault".
- Y. A main circuit breaker disconnect shall be provided for the ASD. For outdoor location, the circuit breaker shall be operable from the front of the NEMA rated enclosure.

2.05 PROVIDE PRODUCT OPTIONS AS FOLLOWS:

- A. Manual Bypass Options:
 - 1. "Auto/Manual" selector switch, to provide convenient switching between "manual" and "auto" modes.
- B. Current limiting, fast acting input fusing, for the protection of ASD semiconductor devices.
- C. Serial communications gateway, for either RS-232 or RS-485, to provide interface from an ASD to; a computer, a Program Logic Controller (PLC), or Building Automation System, for those units which need to interface with such.
- D. For outdoor installations provide a NEMA 3R Enclosure with mechanical ventilation for warm weather and heater for cold weather or prevention of condensation.

2.06 FABRICATION

- A. Enclosure: NEMA Type 1 for indoor installations. For outdoor installations the ASD and bypass shall be contained in NEMA Type 3R enclosure and assembled as ASD manufacturer's standard package. The disconnecting means shall be by circuit breaker accessible from the panel door. Primary switches and indicating lamps for drive function and weatherproof USB connection shall be provided on the enclosure.

2.07 SOURCE QUALITY CONTROL

- A. In-circuit testing of all printed circuit boards shall be conducted, to insure the proper mounting and correct value of all components.
- B. All printed circuit boards shall be burned in for 96 hours, at 85 degrees C.
- C. Final printed circuit board assemblies shall be functionally tested, via computerized test equipment. All tests and acceptance criteria shall be preprogrammed. All test results shall be stored as detailed quality assurance data.
- D. All fully assembled controls shall be functionally tested, with fully loaded induction motors. The combined test data shall then be analyzed, to insure adherence to quality assurance specifications.
- E. Inspect and production test, under load, each completed ASD assembly.

2.08 SURGE PROTECTION

- A. Provide surge protection on the input side of the ASD using a three-phase reactor with a metal oxide varistor (MOV). This protection shall be rated at 5% impedance, 600 volts maximum, 50/60 Hz.

PART 3– EXECUTION

3.01 EXAMINATION

- A. Verify that surface is suitable for ASD installation.
- B. For indoor installations, do not install ASD until the building environment can be maintained, within the service conditions required by the manufacturer.

3.02 INSTALLATION (By Installation Contractor)

- A. Install ASD where indicated, in accordance with manufacturer's written instructions and NEMA ICS 3.
- B. Shading from sun shall be provided for outdoor locations.
- C. Tighten accessible connections and mechanical fasteners after placing ASD.
- D. Provide neatly typed label on each ASD, identifying nameplate horsepower, full load amperes, model number, service factor and voltage/phase rating.
- E. Facilitate work by, and provide assistance to, the manufacturer's representative.
- F. All motors controlled by ASDs shall have shaft grounding brushes installed.

3.03 FIELD QUALITY CONTROL

- A. The manufacturer's representative shall inspect and certify that the installation is in accordance with manufacturer's recommendations. Installation Contractor will correct all deficiencies identified by the manufacturer's representative.
- B. Inspect completed installation for physical damage, proper alignment, anchorage, and grounding. The Installation Contractor and the Manufacturer's representative will both perform the inspection. Installation Contractor will correct all deficiencies identified.

3.04 MANUFACTURER'S FIELD SERVICES (By Furnishing Contractor)

- A. Provide factory trained and authorized startup technician to startup, tune, and test ASD. Warranty shall begin after final acceptance of the project by the owner. Installation Contractor shall facilitate and provide needed assistance.
- B. Provide O&M manuals and training for Owner's facility maintenance personnel.

3.05 ADJUSTING

- A. Adjust work under provisions of Section 230510. Make final adjustments to installed ASD to assure proper operation of fan and/or pump systems.

3.06 TRAINING

- A. In addition to initial startup, provide a minimum of two (2) hours of training for the physical plant staff in the startup, operation, adjustment, and troubleshooting of the ASD. Provide written certification of the training with the signatures of the attendees.

MECHANICAL PAINTING AND IDENTIFICATION

PART 1 - GENERAL

1.01 RELATED DOCUMENTS:

- A. Drawings, Standard General Conditions of the Construction Contract, including Supplementary General Conditions, Division 01 Specification sections and other Division 23 specification sections, apply to work of this section.

1.02 SCOPE

- A. Any equipment or piping that will be labeled which does not come painted, or with other corrosion resistant finish, from the factory shall be painted. All new uninsulated piping shall be painted. Insulated piping with PVC or aluminum jacketing does not require painting. Paint and/or identify the following:
 - 1. Chilled water piping
 - 2. Heating hot water piping.
 - 3. All mechanical equipment including valves
 - 4. All electrical equipment, including panels.
 - 5. Control panel and visible control components.

1.03 SUBMITTALS:

- A. Manufacturer's Data: Submit manufacturer's technical product data and installation instructions.

PART 2 - PRODUCTS

2.01 PLASTIC PIPE MARKERS:

- A. Snap-On Type: Provide manufacturer's standard pre-printed, semi-rigid snap-on, color-coded pipe markers, complying with ANSI A13.1. Provide full-band pipe markers, extending 360 degrees around pipe at each location.
- B. Lettering: Manufacturer's standard pre-printed nomenclature which best describes piping system in each instance, as selected by Engineer in cases of variance with name as shown or specified.
- C. Arrows: Print each pipe marker with arrows indicating direction of flow, either integrally with piping system service lettering (to accommodate both directions), or as separate unit of plastic.

2.02 VALVE TAGS:

- A. Brass Valve Tags: Provide 19-gage polished brass valve tags with stamp-engraved piping system abbreviation in 1/4" high letters and sequenced valve numbers 1/2" high, and with 5/32" hole for fastener.
 - 1. Provide 1-1/2" diameter tags, except as otherwise indicated.
- B. Valve Tag Fasteners: Provide solid brass chain (wire link or beaded type), or solid brass S-hooks of the sizes required for proper attachment of tags to valves and manufactured specifically for that purpose.

2.03 ENGRAVED PLASTIC-LAMINATE SIGNS AND EQUIPMENT MARKERS:

- A. General: Provide engraving stock melamine plastic laminate, complying with FS L-P-387, in the sizes indicated, 1/16" thick, engraved with engraver's standard letter style of the sizes and wording indicated, black

with white core (letter color) except as otherwise indicated, punched for mechanical fastening except where adhesive mounting is necessary because of substrate.

- B. Fasteners: Self-tapping stainless steel screws.

PART 3 - EXECUTION

3.01 PAINTING:

- A. All equipment, except where otherwise specifically noted, shall be furnished in prime coat. All uninsulated black steel piping shall be prime coated, and finish painted in light gray unless otherwise required by schedule below to be color coded. All welds, on both insulated and uninsulated piping, shall be painted with one coat of primer. All miscellaneous black steel items such as hangers and rods, machinery supports, breechings and stacks, etc., shall be prime coated and finish painted in light gray. Exposed surfaces of insulation shall be sealed. All metal surfaces shall be thoroughly cleaned of rust and dirt and shall be degreased before application of primer. All prime coated equipment shall be touched up where prime coats are chipped, scratched, or otherwise damaged. All prime coated equipment shall be thoroughly cleaned and left ready for finish painting. Where cast iron accessories or galvanized pipe, or equipment surfaces are to receive finish painting, the item shall be properly primed.
- B. Ferrous surfaces shall be painted with the following coats:
 - 1. coat of primer equivalent to Bruning Silathane 520-14 grey-green primer, Benjamin Moore 06- 20 red oxide alkyd primer or Richards SR-1399 red metal primer.
 - 2. coats of finish equivalent to Bruning Silathane Gloss Enamel 520-32 quarry gray, Benjamin Moore Gloss Enamel 22-38 or Richards Gloss Enamel 1003 Series.
- C. Insulated piping or equipment with canvas cover shall be painted with the following:
 - 1. primer coat of Sherwin-Williams Problock Latex Primer or equivalent by Bruning Silathane, Benjamin Moore or Richards.
 - 2. finish coats of Sherwin-Williams DTM Acrylic or equivalent by Bruning Silathane, Benjamin Moore or Richards.
- D. Finish painting of all equipment and piping (both insulated and uninsulated) shall be provided. Where indicated, specified or exposed to view, existing equipment, piping, duct, etc. shall be cleaned and painted along with new work. Do not paint piping that is provided with aluminum or PVC jacketing insulation covering. Paint piping insulation per color schedule below and provide stenciled identification or plastic pipe markers.
 - 1. Painting and/or identification shall be in accordance with the following schedule:

<u>ITEM</u>	<u>IDENTIFICATION</u>	<u>MARKER BACKGROUND</u>	<u>LETTERING COLOR</u>
Chilled Water	CHWS, CHWR	Green	White
Heating Hot Water	HHWS, HHWR	Red, Orange	White

- E. All other uninsulated ferrous pipes shall be painted light gray with stenciled identification as specified under stenciling.
- F. The interiors of ductwork visible through grilles, registers, diffusers, or other duct openings, and/or interiors that can reflect light shall be painted flat black.

3.02 GENERAL MECHANICAL IDENTIFICATION:

- A. Coordination: Where identification is to be applied to surfaces which require insulation, painting or other

covering or finish, including valve tags in finished mechanical spaces, install identification after completion of covering and painting.

3.03 PIPING SYSTEM IDENTIFICATION:

- A. General: Install plastic pipe markers on each system indicated to receive identification.
- B. Locate pipe markers and color bands as follows:
 - 1. Near each valve and control device.
 - 2. Near each branch.
 - 3. Near locations where pipes pass through walls or floors/ceilings or enter non-accessible enclosures.
 - 4. Near major equipment items and other points of origination and termination.
 - 5. Fuel gas piping shall be labelled every 5'. Other services shall be spaced intermediately at maximum spacing of 50' along each piping run, except reduce spacing to 25' in congested areas of piping and equipment and in mechanical rooms.
- C. Stenciling: In lieu of plastic pipe markers, stenciling may be used for identification. Apply stenciling after finished painting has been completed. Stencil indication shall be in block letters, applied with black paint (except white paint on black surface) as follows:
 - 1. Stencil as follows:

<u>OD Pipe or Covering</u>	<u>Stencil Letter Size</u>
3/4 in. thru 1-1/4 in.	1/2 in.
1-1/2 in. thru 2 in.	3/4 in.
2-1/2 in. thru 4 in.	1 in.
6 in. and larger	2 in.

- D. All underground lines outside the building footprint, except lawn irrigation lines, shall have a warning tape installed in the backfill between 6 inches to 24 inches below finished grade directly over piping.
 - 1. Metallic lines shall be identified with durable printed plastic warning tapes, minimum 3 inches wide, with lettering to identify buried line below.
 - 2. Non-metallic pipes shall be marked using an approved tracer. A yellow insulated copper tracer wire or other approved conductor shall be installed adjacent to and over the full length of underground nonmetallic piping. Access shall be provided to the tracer wire or the tracer wire shall terminate at the edge of the building and where the pipe stubs up out of the ground. The tracer wire size shall not be less than 14 awg and the insulation shall be listed for direct burial.

3.04 VALVE IDENTIFICATION:

- A. General: Provide valve tag on every valve, cock and control device in each piping system. List each tagged valve in typed valve schedule for each piping system, and post under glass in main mechanical room and/or boiler room.

3.05 MECHANICAL EQUIPMENT IDENTIFICATION:

- A. General: Install engraved plastic laminate sign or plastic equipment marker on or near each major item of mechanical equipment and each operational device, as specified herein if not otherwise specified for each item or device. Provide signs for the following general categories of equipment and operational devices:
 - 1. Chiller
 - 2. ASDs
 - 3. Control Panels
 - 4. Enclosed Circuit Breakers

5. Pumps
6. VAV Boxes
7. Main control and operating valves, including safety devices

END OF SECTION 23 05 90

TESTING AND BALANCING OF HVAC SYSTEMS

PART 1 - GENERAL

1.01 RELATED DOCUMENTS:

Drawings and Standard General Conditions of the Construction Contract, including Supplementary General Conditions and Division 01 Specification sections, and other Division 23 specification sections, and Division 26 specifications apply to work of this section.

1.02 DESCRIPTION OF WORK

- A. The Testing and Balancing (TAB) work shall be done by an agency certified by the Associated Air Balance Council (AABC). The Agency shall show proof of having successfully completed at least five projects of equal size and scope within the previous three years. If the contractor is not so qualified, he shall subcontract the work to a qualified subcontractor.
- B. Immediately after the award of a contract, the contractor shall perform a Design Review of the mechanical plans and specifications. He shall identify any omissions or discrepancies that will preclude the proper balancing of the systems and report same to the Owner in a formal report.
- C. Test and balance HVAC air systems as shown and specified on the schedules and Contract Documents and make submittals as described in this Section.

1.03 SUBMITTALS - Submit the following to the Owner's Representative for approval:

- A. Inspection reports (prior to and during testing and balancing).
- B. Other tests, records, certifications and reports as specified in this Section.
- C. Associated Air Balance Council (AABC) or National Environmental Balancing Bureau (NEBB) Certification
- D. List of instruments actually used for each test. Include instrument calibration dates.
- E. TAB report including preliminary and final balance data sheets (see Paragraph 3.05). Also submit to Engineer for record.

1.04 REFERENCE STANDARDS

- A. Unless shown or specified otherwise, the TAB work shall comply with the following:
 - 1. AABC National Standards or National Environmental Balancing Bureau (NEBB) Standards for Field measurements and Instrumentation.
 - 2. ASHRAE 110-1985: Method of Testing Performance of Laboratory Fume Hoods.
 - 3. HVAC Systems Testing, Adjusting, and Balancing, Sheet Metal & Air Conditioning Contractor's National Association, Inc. (SMACNA), 1993.

1.05 QUALITY ASSURANCE

- A. The organization performing the TAB work shall be certified by the Associated Air Balance Council (AABC) or the National Environmental Balancing Bureau (NEBB).
- B. The work shall be performed by regular employees specifically trained in the total balancing of air systems. The work shall be continuously conducted under the direct supervision of a Professional Engineer registered

in the State of North Carolina who is a certified Test and Balance Engineer by AABC or NEBB and is experienced in testing and balancing of HVAC systems.

PART 2 - PRODUCTS

NOT USED

PART 3 - EXECUTION

3.01 GENERAL

- A. Adjust, test and confirm water flow rates, pressure drops, pressures, and temperature of HVAC system, including chilled water systems, all associated pumps, chillers, and performing accessories. This shall include all new components.
- B. Provide preliminary and final (2 phases) testing and balancing. Initiate preliminary testing and balancing immediately after certification of chiller and pumps (before controls, labeling, etc. are completed). Confirm macro level performance of devices. The preliminary phase shall be followed by a submitted written report of system shortcomings which prohibit final balancing. Following preliminary testing and balancing, if balancing or control devices are not operating correctly, report these conditions to the Owner's Representative, who shall coordinate required corrections so that balancing can continue.
- C. Perform the work using methods and test forms published by AABC National Standards for Field Measurements and Instrumentation (No. 71679, 2nd edition or any later edition) or corresponding NEBB methods and forms.
- D. Do not start final testing and balancing until each system has been certified to be complete.
- E. Using controls and devices installed, test and balance air conditioning systems with maximum attainable internal load (lights and equipment), or simulated maximum load using automatic temperature controls, whichever is closest to design operating conditions.
- F. Do the final testing and balancing of air handling systems with finished ceilings and partitions in place and doors closed.
- G. Use volume control devices to regulate air quantities only to the extent that adjustments do not create objectionable air motion or sound levels. Effect volume control by duct internal devices such as dampers and splitters.
 - 1. Vary total system air quantities by adjustment of fan speeds through the adjustable speed drives. Vary branch air quantities by damper regulation. Minimize use of balancing devices to "throttle" flow. When balanced, all volume control devices in the path to the terminal with the highest pressure drop shall be fully open.
 - 2. Adjust OA intake on AHU's according to drawings, schedules, and specifications.
 - 3. Balance VAV Boxes at maximum airflow rate, full cooling, and at minimum air flow, full heating.
 - 4. For variable air volume system powered units set volume controller to airflow settings indicated. Confirm connections are properly made and confirm proper operation for automatic VAV temperature control.
- H. Do not trim impeller for pumps with adjustable speed drives. Adjust and mark speed to produce the design flow.
- I. Have on the job site the AABC or the National Environmental Balancing Bureau (NEBB) standards referred

to herein, and make them available to the Mechanical Contractor and the Owner's Representative.

- J. The Owner's Representative shall be given the option to witness final testing and balancing of all systems. The Testing and Balancing Contractor shall notify the Owner's Representative ten (10) working days prior to each system being tested and/or balanced.
- K. Repair or replacement of finished products damaged as a result of testing, balancing and inspection work shall be the responsibility of the Contractor.

3.02 INSTRUMENT CALIBRATION

- A. Provide written certification of the accuracy of all instruments furnished or used for Testing and Balancing. Show date and method of calibration. All instruments shall have been calibrated within six (6) months prior to the estimated completion date of balancing work.
- B. Verify the accuracy of permanently-installed flow-measuring primary elements and their read-out instruments, thermometers, sensors and pressure gauges furnished under this contract. Verification may be by calculation and calibration of the primary element and read-out instrument, or by an independent measurement of the flow, temperature or pressure of the flow, of the same flowing medium using calibrated instruments. Submit a report of certification, verification, or inaccuracy of all calibrations.

3.03 BALANCING PROCEDURES AND RELATED WORK

- A. Balancing shall achieve design hydronic flow rate, within a tolerance of -5% to +10% on major equipment (AHU's, Fans, Pumps) and +/- 10% at terminal points (air outlets, inlets, transfer air quantities, coil water flow rates, etc.).
- B. Verify that all controls and the devices they control (such as valves, dampers, variable volume terminal boxes, chillers, pumps, etc.), operate as they are intended and in the sequence specified. Report device failures in bi-weekly reports.
- C. Permanently-installed flow-measuring elements may be used to accomplish balancing after accuracy has been verified with certified calibrated instruments. Records and report read-outs of these instruments for all flows even if not required for testing and balancing results.
- D. Perform test and balance on new chilled water pump CWP. The test and balance contractor shall determine the speed required for the desired maximum flow for the pump and the associated ASD shall be set to modulate up to that speed. Refer to the Chilled Water Plant Control sequence on Drawing Sheet M-600.
- E. Perform test and balance on new hot water pump HWP. The test and balance contractor shall determine the desired flow for the pump and record the required setting for the triple duty valve. Contractor shall pull and trim the impeller after a proportional balance has been done only if necessary.
- F. Protect read-out instruments from damage and return them in good working order to the Mechanical Contractor.
- G. Only direct-flow measurement may be used. Do not use indirect calculations, such as a heat balance or pressure drop in a heat exchanger.
- H. Balance air system minimum and maximum damper positions for correct operation at both maximum design outside air and minimum outside air, maximum and minimum return air, etc.
- I. Balance air systems in all modes of operation, including unoccupied, occupied, warm-up, and cool-down. Report on a room-by-room basis on the total flow of each room. Confirm flow at occupied and unoccupied modes.
- J. Provide required openings for duct traverses. Seal test holes in ducts with snap-in plugs. In addition, plugs

shall be airtight type and/or sealed airtight in 1% and dust collection leak class systems. Tape is not permitted. Repair insulation where damaged. Mark insulation where readings were taken.

- K. Record the test data for each motor, fan, pump, air system, boiler, and chiller. Apply temperature, barometric and other correction factors for non-standard conditions and record in report.
- L. Record the clean filter pressure drop across all air filters where magnahelic gauges have been provided at design operating cfm after final balancing.

3.04 TEST AND RECORDS

- A. Submit a separate test report for each air and hydronic system outlining actual temperatures, pressure drops and flow rates at all terminal devices (e.g., terminal boxes, air terminals, pumps, coils, etc.) And compare totals to the flow measurements taken at the source (e.g., fans and pumps) and to the design parameters.
- B. In addition, record test data where applicable on the appropriate standard test forms from AABC National Standards or corresponding NEBB forms.

- 1. Air Moving Equipment Test Sheet
- 2. Fan and Motor Pulley
- 3. Duct Traverse Readings
- 4. Air Distribution Test Sheet
- 5. Terminal Units
- 6. Pump Data Sheet
- 7. Chillers
- 8. Cooling Coil Data
- 9. Heating Coil Data

- C. In addition to tests and records for the foregoing equipment, tests and records are required for the following:

- 1. Heat Transfer Coils, including nameplate data and, for both design and actual conditions, the following:
 - a. Inlet and outlet air temperature and, for cooling, both wet and dry bulb temperatures and 2-foot vertical and horizontal centers at air handlers.
 - b. Air pressure drop.
 - c. Air face velocity on 2-foot vertical and horizontal centers at air handlers
 - d. Water pressure, in and out.
 - e. Water pressure drop.
 - f. Outside air temperature.
 - g. Entering and leaving coil water temperature.
 - h. Calculate air BTU/hr versus water BTU/hr.

- C. In addition to data required on National Environmental Balancing Bureau (NEBB) or AABC forms, the following additional information is required for all scheduled equipment:

- 1. Motors - Type, frame, number, serial number, and calculated brake horsepower and efficiency at final condition.
- 2. Pumps
 - i. Design Data - Impeller size, motor hp, net positive suction head (NPSH) required at design flow, and total dynamic head (TDH) at zero flow.
 - j. Test Data - Suction and discharge pressures at full flow (not throttled to obtain rated flow), and zero flow.
- 3. Hydronic Systems - GPM in each significant branch, and position of each balancing valve.

4. Variable Air Volume Boxes, Dampers and Fan Terminal Boxes - Test inlet pressure to boxes and dampers, one per branch duct, and confirm the performance, minimum/maximum cfm, response of box and reheat coil to thermostat, or space temperature sensor, minimum closure cfm.
5. Fan and Pump Systems - For systems controlled by static pressure, assure by test and recording that devices, including high limit controls are calibrated to perform in accordance with Contract Documents, and provide design static pressure at the most demanding location. Furnish and coordinate static pressure setpoint of controls, as applicable, with Controls Contractor.

3.05 TESTING AND BALANCING REPORTS

- A. Submit preliminary and final testing and balancing reports for approval.
- B. Arrange recorded data by system, using the appropriate designations as established in the Contract Documents. Submit three signed, bound and indexed copies of both preliminary and final reports to the Owner's Representative. Also submit the reports electronically in pdf format.
- C. Where actual measurements recorded for the final balance show deviation of more than the specified tolerance from the design, and the deviation cannot be corrected by balancing with the installed layout and elements, note this deviation in the final report with recommendations for corrective action.
- D. In those cases where recorded data can be reasonably interpreted to be inaccurate, inconsistent or erroneous, the Owner's Representative may request additional testing and balancing. The Testing and Balancing Contractor shall, at no additional cost to the Owner, perform such re-testing and re-balancing as directed by and in the presence of the Owner's Representative.
- E. Where, in the opinion of the Testing and Balancing Contractor, there is excessive vibration, movement or noise from any piece of equipment, ductwork, or piping, these conditions should be noted in the final report with recommendations for corrective action.

END OF SECTION 23 05 94

PART 1 – GENERAL

1.01 RELATED DOCUMENTS AND RELATED WORK SPECIFIED ELSEWHERE:

A. Related Documents

1. Drawings, Standard General Conditions of the Construction Contract, including Supplementary General Conditions, Division 01 Specification sections, other Division 23 specification sections, and Division 26 specifications apply to work of this section.

1.02 RATING

- A. All insulation systems, including jackets and adhesives shall be U.L. rated and FM approved. All insulation for indoor use shall have a maximum permanent flame spread rating of 25 or less and a smoke developed rating of 250 or less, except insulation installed in an air plenum shall have a maximum permanent flame spread rating of 25 or less and a smoke developed rating of 50 or less, as tested by ASTM E 84 (NFPA 255) method. Outdoor mechanical insulation may have flame spread index of 75 and smoke developed index of 450. Submit smoke and flame ratings for every material proposed for use.

1.03 SCOPE

A. Furnish and install insulation for the following:

1. Exposed mechanical equipment not pre-insulated by manufacturer that contains hot, chilled or cold make-up water.
2. Hot and Chilled water piping.
3. Repair any existing insulation damaged during construction and/or removed for tie-in to new piping.

1.04 QUALITY ASSURANCE

- A. Insulation shall be installed by a contractor who specialized in the mechanical insulation trade and worked on projects of similar size and complexity over the past five years.
- B. Insulation contractor shall be member of either the National Insulation Association (NIA) or the Southeastern Insulation Contractors Association (SEICA).
- C. In place of these memberships, the contractor can provide favorable letters of reference from three previous project representatives.

1.05 SUBMITTALS

- A. Submit manufacturer's technical product data and installation instructions for each type of mechanical insulation. Submit schedule showing manufacturer's product number, k-value, thickness, and furnished accessories for each mechanical system requiring insulation.
- B. Submit, if requested by Designer, manufacturer's sample of each piping insulation type required, and of each duct and equipment insulation type required. Affix label to sample completely describing product.

PART 2 - PRODUCTS

2.01 PIPE INSULATION

A. Preformed Fiberglass Pipe Insulation:

1. Manufacturer: Subject to compliance with the requirements, provide products from one of the following manufacturers:
 - a. Knauff
 - b. Johns Manville
 - c. Owens Corning
 - d. Certainteed
2. Material: Mineral fiber, pre-formed pipe insulation, maximum K-factor of .24 at mean temperature of 75°F. All insulation shall have a jacket of white kraft paper reinforced with a glass fiber yarn and bonded to an aluminum foil, with self-sealing longitudinal laps and butt strips. Jacket shall comply with ASTM C1136 (Type 1).
3. Insulate all fittings, valves and strainers with molded fittings, mitered segments of pipe insulation or over-sized pipe insulation held in place with wire. Finish in accordance with manufacturer's recommendations to comply with the UL Systems listing.

B. Flexible Elastomeric Pipe Insulation:

1. Manufacturer: Subject to compliance with the requirements, provide products from one of the following manufacturers:
 - a. Armacell AP Armaflex
 - b. Aeroflex USA
 - c. K-flex USA
 - d. Nomaco FlexTherm
2. Material: Closed cell pre-formed flexible elastomeric foam insulation. Comply with ASTM C 534 with maximum thermal conductivity (k value) of 0.27 at 75 degrees F.
3. Fittings, valves, and piping components - Sleeve type fitting covers and miter cut tubular form.
4. Insulation Adhesive – As recommended by manufacturer.

C. Polyisocyanurate Pipe Insulation:

1. Manufacturer: Subject to compliance with the requirements, provide products from one of the following manufacturers:
 - a. Apache Products Company
 - b. ITW
 - c. Duna USA
 - d. Elliott Company
2. Material: Closed cell pre-formed polyisocyanurate foam insulation. Comply with ASTM C 591, Type I or IV, except thermal conductivity (k-value) shall not exceed 0.19 at 75 degrees F. All insulation shall have a jacket of white kraft paper reinforced with a glass fiber yarn and bonded to an aluminum foil, with self-sealing longitudinal laps and butt strips. Jacket shall comply with ASTM C1136 (Type 1).
3. Fittings, valves, and piping components - Sleeve type fitting covers and miter cut tubular form.

2.02 HEAT TRACE SYSTEM

1. Self-regulating type with 16 AWG nickel-plated copper bus wires, semi-conductive self-limiting matrix, and cross-linked polyolefin insulating jacket.
2. Provide 5.0 watts per foot for pipe sizes up to 4", 8 watts per foot for pipe sizes 5" through 8", and 12 watts per foot for pipe sizes above 8". For this project use 5XL1-CR heating cable.
3. Heat tape shall be hard wired to the heat trace circuit through an electronic controller. The electronic controller shall have an adjustable set point between 32°F and 200°F. The enclosure shall be NEMA 4X fiberglass reinforced polyester plastic. The controller shall be rated for voltages from 100 to 277V,

be capable of switching up to 30 Amperes, and include ground-fault protection. The controller shall come with a 25 ft. temperature sensor. Controller shall have a dry contact which shall be connected to the HVAC DDC system to report alarms. The unit shall be UL Listed and/or CSA certified for nonhazardous locations. This description is specifically for Model ECW-GF by Raychem. Controllers for other manufacturer's systems shall be comparably adjustable, rugged, listed and certified.

4. System shall be installed using RAYCLIC-PC power connection and end seal fittings, GT-66 glass tape and other manufacturer recommended accessories.
5. Provide warning labels to indicate there is heat trace cabling installed.
6. Convenience or service outlets shall not be used for heat tape.
7. All components shall be installed as a system from the same manufacturer.
8. Manufacturer: Raychem XL-Trace (Basis of Design), Thermon FLX, Chromalox or approved equal.

2.03 FIELD APPLIED JACKETS

- A. Where required, the following jackets shall be applied in addition to the insulation jacket specified above.
 1. PVC fitting covers and jacketing, .030" (.3 mm) thickness of white, gloss finish, weatherable grade, UV resistant, PVC material. Flame spread/smoke developed of 25/50 per ASTM-E84. Install per manufacturer's specification.
 - a. Fitting covers shall be shaped to exact fit. Longitudinal seam shall lap over from above to drain rain water overlap.
 - b. Attach with weld adhesive product provided by the jacket manufacturer. Provide bands as required and where requested.
 - c. Manufacturers: John Manville Zestar 300, Owens Corning Speedline or Knauf PVC Jacketing Fitting Covers.
 2. Canvas Jacket: UL listed fabric, 8 oz/sq yd, plain weave cotton treated with dilute fire retardent lagging adhesive.
 3. Aluminum Jacket: 0.016-inch-thick sheet, embossed finish, with longitudinal slip joints and 2 inch laps, die shaped fitting covers with factory attached protective liner.

B. Removable Insulation Jackets

1. Manufacturer: Subject to compliance with the requirements, provide products from one of the following manufacturers:
 - a. URIP, Inc.
 - b. Thermax, LLC
 - c. Thermal Energy Products
 - d. HotCaps by Ohio Valley Industrial Services
2. Insulation Material: Flexible Elastomeric or Fiberglass insulation as applicable for system. Insulation shall comply with applicable requirements specified above.
3. Jacket: Silicone Impregnated Fiberglass 17 oz. / sy.
4. Securing method: Ballistic Nylon strap 1-1/2" with buckles or quick release clasps.

2.04 DUCT INSULATION

A. Mineral Fiber Blanket Insulation:

1. Manufacturer: Subject to compliance with the requirements, provide products from one of the following manufacturers:
 - a. Knauff
 - b. Johns Manville
 - c. Owens Corning
 - d. Certainteed

2. Material: Mineral or glass fiber, duct wrap 1 lb. density with FSK facing complying with ASTM C1290. Maximum K-factor of .31 at 75°F. Jacket shall be FSK aluminum foil reinforced with fiber glass yarn and laminated to fire resistant kraft paper, secured with UL listed pressure sensitive tape and outward clinch expanding staples and vapor barrier mastic.

B. Mineral Fiber Board Insulation:

1. Manufacturer: Subject to compliance with the requirements, provide products from one of the following manufacturers:
 - a. Knauff
 - b. Johns Manville
 - c. Owens Corning
 - d. Certainteed
2. Material: Mineral or glass fibers bonded with thermosetting resins complying with ASTM C612, Type I. 3 lb. density with maximum K-factor of 0.23 at 75°F mean temperature. Jacket shall be FSK aluminum foil reinforced with fiber glass yarn and laminated to fire resistant kraft paper, secured with UL listed pressure sensitive tape and outward clinch expanding staples and vapor barrier mastic.

C. Mineral Fiber Acoustic Liner:

1. Manufacturer: Subject to compliance with the requirements, provide products from one of the following manufacturers:
 - a. Knauff
 - b. Johns Manville
 - c. Owens Corning
 - d. Certainteed
2. Material: Mineral or glass fibers bonded with thermosetting resin complying with ASTM C1071. Made from inorganic glass fiber, min. NRC 0.85, 1-inch thick, minimum R-value of 4.0.
3. The air stream surface shall have a 100% coverage coating of acrylic polymer formulated with an immobilized EPA registered anti-microbial agent proven resistant to microbial growth as determined by ASTM G21 and G22.

PART 3 - EXECUTION

3.01 GENERAL REQUIREMENTS

- A. All insulation shall be applied by experienced pipe coverers and journeymen in accordance with best trade practice. Work shall be as recommended by manufacturer's latest printed installation directions. Test, inspect, and clean all surfaces to be insulated before applying insulation. Take all possible precautions to protect work of other trades. Provide protective covering as required to accomplish this and be responsible for returning all equipment and material to its original new condition and appearance where damage occurs due to neglect.
- B. Protect insulation where supported in hangers by means of inserts or saddles sufficiently large to prevent crushing of insulation. At minimum provide insulated supports on all water piping greater than 1"Ø.
- C. Apply adhesive to exposed risers to prevent slipping and turning.
- D. Butt covering neatly to walls, floors, ceiling. Apply bands at end and position so band covers gap between surface and insulation where exposed.
- E. At butt ends of insulation the jacket material shall be pulled over exposed ends and secured with bands to give a neat and finished appearance. Exposed fiberglass material will not be permitted.

- F. In locations where it will be exposed to view do not apply insulating cement on visible side. Orient seams of jacket away from view.
- G. Insulation on all cold surfaces must be applied with a continuous, unbroken vapor seal. Any hangers, supports, anchors, etc. that are secured directly to cold surfaces must be adequately insulated and vapor sealed to prevent condensation. Seal pipe terminations every four sections using Foster 30-35 or equal by Miracle or Mon-Eco Industries, Inc.
- H. Heat Trace Tape shall be wired through a remote bulb thermostat monitoring ambient temperature set at 40°F.
- I. Provide corrugated aluminum jacket on all vertical piping within 8' of floor in all occupied areas and mechanical rooms.

3.02 PIPE INSULATION SHALL BE APPLIED AS FOLLOWS:

Area	Pipe System	Insulation	Thickness	Jacket
All above grade, exposed to view	Interior Chilled and Makeup Water < 2" Ø	Polyisocyanurate	1"	PVC
All above grade	Exterior Chilled and Makeup Water < 2" Ø	Polyisocyanurate	2"	Corrugated Aluminum
Interior Concealed, not in air plenum	Chilled and Makeup Water ≥ 2" Ø	Polyisocyanurate	1-1/2"	None
Interior Exposed	Chilled and Makeup Water ≥ 2" Ø	Polyisocyanurate	1-1/2"	Canvas > 8' AFF PVC < 8' AFF
Exterior	Chilled and Makeup Water ≥ 2" Ø	Polyisocyanurate	2"	Corrugated Aluminum
Interior Air Plenum	Chilled and Makeup Water ≤ 2" Ø	Polyisocyanurate	1-1/2"	None
Interior Air Plenum	Chilled and Makeup Water ≥ 2" Ø	Polyisocyanurate	1-1/2"	None
Mech Room	Chilled Water and Makeup Water ≥ 2" Ø	Polyisocyanurate	1-1/2"	Canvas > 8' AFF Corrugated Aluminum < 8' AFF
Interior	Heating Hot Water ≤ 1.5" Ø	Preformed Fiberglass	2"	Corrugated Aluminum

Interior	Heating Hot Water > 1.5" Ø	Preformed Fiberglass	2"	Corrugated Aluminum
Mech Room > 8' AFF	Heating Hot Water ≤ 1.5" Ø	Preformed Fiberglass	2"	Canvas >8'AFF Corrugated Aluminum <8'AFF
Mech Room > 8' AFF	Heating Hot Water > 1.5" Ø	Preformed Fiberglass	2"	Canvas >8'AFF Corrugated Aluminum <8'AFF
Interior and Mech Room	Condensate drain piping	Flexible Elastomeric	1-1/2"	PVC

3.03 DUCT INSULATION SHALL BE APPLIED AS FOLLOWS:

Area	Duct System (including plenums)	Insulation	Thickness	Jacket
Mechanical Rooms	Single wall supply and outside air	Mineral Fiber Board	2"	None
Concealed Interior	Single wall supply	Mineral Fiber Blanket	2"	None
Where noted on the drawings	Supply, Return, and Relief	Acoustic Duct Liner	1"	None

3.04 SPECIFIC REQUIREMENTS

A. Flexible Elastomeric Pipe Insulation:

1. Installation - Butt edges tightly, secure with elastomeric foam adhesive as recommended by insulation manufacturer.

B. Mineral Fiber Blanket Insulation:

1. Mineral fiber blanket insulation shall be applied over clean, dry sheetmetal duct. Before applying the insulation all joints and seams shall be sealed air tight. Duct wrap shall be installed to allow maximum fullness at corners. Minimum thickness at corners is one inch. Insulation shall be butted tightly at joints and vapor barrier facing shall be overlapped at minimum of 2 inches. Insulation shall be butted tightly at joints and vapor barrier facing shall be overlapped at minimum of 2 inches. Insulation should be removed from lap prior to stapling. All seams shall be stapled approximately 6 inches on center with outward clinching staples, then sealed with a foil vapor barrier tape, or vapor barrier mastic. Where ducts are over 24 inches in width, the duct wrap shall be additionally secured to the bottom of rectangular ducts with mechanical fasteners spaced on 18 inch centers (maximum), to prevent sagging of insulation. Seal penetrations so as to provide a vapor-tight system.

C. Mineral Fiber Acoustic Liner.

1. Tape all edges and joints of insulation and protect leading edges and joints of insulation by metal strips. Duct size shall increase 2 inches in each direction where insulation is installed inside of duct.
2. Coated duct liner shall be cut to assure overlapped and compressed longitudinal corner joints. Apply liner with coated surface facing the air stream and adhere with 100% coverage of fire-retardant adhesive. Coat all exposed leading edges and all transverse joints with fire-retardant adhesive. The liner shall be additionally secured with mechanical fasteners which shall compress the duct liner sufficiently to hold it firmly in place as follows:
 - a. Velocities to 2000 FPM: Fasteners shall start within 3 inches of the upstream transverse edge of liner and 3 inches from o.c. around the perimeter of the duct, except that they may be a maximum of 12 inches from a corner break. Elsewhere they shall be a maximum of 18 inches o.c. except that they be not more than 6 inches from a longitudinal joint of liner nor 12 inches from a corner break. Coat all exposed joints and edges of transverse joints with a fire-retardant adhesive.
 - b. Velocities from 2000 to 4000 FPM: Fasteners shall start with 3 inches of the upstream transverse edges of the liner and 3 inches from the longitudinal joints and shall be placed at a maximum of 6 inches o.c. around the perimeter of the duct, except where they shall be a maximum of 6 inches from a corner break. Elsewhere they shall be a maximum of 16 inches o.c. except that they shall be placed not more than 6 inches from a longitudinal joint of the liner nor 12 inches from a corner break. In addition to adhesive edge coating of transverse joints, any longitudinal joints shall be similarly coated with adhesive.

D. Supply ducts which have acoustic liner shall also be insulated on the outside.

E. Install heat tracing prior to insulation for all water piping exposed to ambient temperature. Install per manufacturer's instructions. Perform and record the results of an insulation resistance test as required by the manufacturer. Install warning labels every 10 feet on the exterior of the insulation jacketing.

F. Insulation shall be installed according to manufacturer recommendations. Insulation over the expansion joint and the flexible section shall be loose and of adequate length to permit the movement of pipe or duct.

G. Provide removable insulation jacket at all valves, pump volutes, strainers, and other system components that are not factory insulated but requires regular service. Insulation shall match adjacent pipe insulation.

3.05 DO NOT INSULATE

A. Vibration eliminators.

B. Equipment nameplates.

END OF SECTION 23 07 00

PART 1 - GENERAL**1.01 RELATED WORK SPECIFIED ELSEWHERE**

- A. All work of this Division shall comply with the requirements of the Drawings, Standard General Conditions of the Construction Contract, including Supplementary General Conditions and Division 01 Specification Sections.
- B. Section 23 05 30 – Electrical Provisions for Mechanical Work
- C. Division 26 – Electrical
- D. Division 27 – Communications

1.02 DESCRIPTION

- A. Furnish and install a web-based Energy Monitoring and Control System (EMCS), with point and click graphics, using Direct Digital Controls described herein. The new system shall be a completely integrated system employing **BACnet IP** protocols. Furnish all labor, materials, equipment, and service necessary for a complete and fully operational system. Drawings are diagrammatic only. The system shall be complete in all respects including all devices to provide the function described herein, regardless of whether specifically mentioned or not. This shall include HVAC control, energy management, alarm monitoring, and all trending, reporting and maintenance management functions required for normal building operations as indicated on the drawings or elsewhere in this specification.
- B. Alternate proposals or substitutions, where provided, must conform to plans or specifications in detail, and any deviation, no matter how minor, must be included in the list of deviations submitted with the bid. Any proposed system with deviations which, in the opinion of the Owner and/or the Engineer, alter the basic intent of the specifications will not be accepted.
- C. The system being installed shall be compatible with current and future plans for control and monitoring of the HVAC systems in the building.
- D. The EMCS shall be stand-alone with a building control unit, BAS LAN and one (1) ethernet connection to the Town's wide area network. The system shall use the existing building Ethernet Network for data communication between the building and the Web Server.
- E. Provide the following electrical work as work of this section, complying with requirements of Section 23 05 30, Division 26, and Division 27 sections:
 - 1. Control wiring between field-installed controls, sensors, relays, transducers, indicating devices, and unit control panels.
 - 2. Interlock wiring between electrically-operated equipment units and between equipment and field-installed control devices.

1.03 WORK INCLUDED

- A. The following work is specifically included without limiting the generality implied by these specifications and drawings.
 - 1. Installation of a microprocessor based direct digital control (DDC) system to control HVAC equipment

and systems for space conditioning, night setback, demand limiting, etc. All new controls shall be electronic.

2. Cutting and patching as required for the introduction of work as shown on the plans and as specified in this Division. This includes wall repair and painting of locations where existing thermostats are removed and re-insulation of pipe and duct where control devices are installed.
3. Providing all internal and external wiring for the Direct Digital Control System.
4. Furnishing for installation by others, sensor wells and sockets, control valves, damper motors and other items of equipment indicated on the Drawings.
5. Contractor shall purchase Weil-McLain part # 383-600-322 Modbus converter to BACnet. This shall be installed to allow BACnet communication with the existing Weil-McLain model Slimfit 750 boiler.
6. Demolition of existing control devices, wiring, and equipment no longer in use.
7. Provide all needed equipment and wiring to install the local area network within the building and provide the capability of accessing the system locally by connecting through laptop computers, monitoring remotely via web browser, and remote interface via mobile applications for Android and iOS platforms.
8. Provide all software, hardware, programming, cables, wiring, devices, etc. for a complete and operational project. Install the necessary system software on the owner's central station computer.
9. Provide assistance to contractor and Carrier technicians during chiller start-up.
10. Coordinate integration of BACnet interface with Carrier technicians for the new chiller.
11. Provide start-up and testing of the system.
12. Provide owner training on system operation, programming, and maintenance.

1.04 SHOP DRAWINGS

- A. Submit for approval apparatus bulletins and data sheets for all control components, valves, damper and room schedules showing size, configuration, capacity and location of all equipment. Include complete control diagrams with system description, wiring diagrams and installation and maintenance instructions.
- B. All control wires shall be color coded and labeled. All control wires shall be orange to distinguish between existing white and blue data cabling.

1.05 ELECTRICAL WIRING

- A. Refer to Section 23 05 30 for wiring required under this Section.
- B. All wiring shall be done in accordance with the latest edition of the National Electric Code, Division 26, Division 27, and the North Carolina State Building Code.
- C. All wiring associated with the direct digital control system shall be by this Division.
- D. Wiring methods:
 1. All line voltage wiring shall be in conduit.
 2. All low voltage control and signal wiring shall be in conduit in walls, mechanical rooms and where exposed.
 3. To the extent feasible, all sensor drops in existing walls shall be fished in the wall, routed down in closets, or otherwise concealed, or pulled through existing conduit.
 4. All wiring in finished areas shall be in surface raceway with the color to match the existing finish but only used where specifically approved.
 5. All penetrations of rated walls and floors shall be fire stopped in accordance with the NC Building Code, drawing notes, and UL details indicated on the drawings.
 6. Plenum cable shall only be used in concealed locations above ceilings and shall be neatly routed on J-hooks.
- E. All cabling pathways shall be coordinated with the owner's IT Department.

1.06 GUARANTEE

- A. Control system specified herein shall be guaranteed free from original defects in material and workmanship for a period of two years of normal use and service after final inspection and acceptance of the project. Same-day service on warranty issues shall be guaranteed if a service call, from the Owner to Contractor, is placed before 12:00 noon. Except in the case of an emergency, warranty items will be addressed during normal working hours.
- B. The contractor shall provide one (1) year of maintenance service for the HVAC controls system to begin concurrently with the first year of warranty. Service shall include inspection and adjustment of all operating controls and components during the alternate season from when it was installed (ie. if installed in summer, adjust in winter). A service report shall be provided to the Owner.
- C. The control system manufacturer shall state that equipment compatible with that being bid will be available for at least three years after acceptance of this work. Support and stock shall be available for at least five years.
- D. The manufacturer shall provide, free of cost, any upgrades to the software for a period of three years from acceptance of this work.

1.07 QUALIFICATION FOR MICROPROCESSOR BASED ENERGY MANAGEMENT EQUIPMENT SUPPLIER

- A. If the system is not installed by the manufacturer, the installing contractor's primary business shall be the installation of Temperature Control and Direct Digital Control Systems, and he shall have a minimum of ten (10) years' experience in the installation and service of microprocessor-based systems. The installer shall be approved by the manufacturer for both installation and maintenance of building systems and equipment. Upon request, the contractor should be able to provide a list of at least three other installations where he has installed a system of similar size and scope. Failure to show at least three successful installations will disqualify the contractor.
- B. The contractor shall have a local office within a 75-mile radius of the job, staffed with factory trained engineers capable of providing instruction, routine maintenance, and emergency maintenance service. The local office shall also maintain an adequate stock of spare parts needed for normal servicing and repairs.
- C. Make: Control system shall be by a company licensed to work on and install Controls system and capable of meeting all required operations and functions. Subject to compliance with requirements, provide products by one of the following:
 - 1. Honeywell
 - 2. CMS Controls
 - 3. Engineered Control Solutions
 - 4. Envirocon (located in Wilson, N.C.)
 - 5. Envirotrol LLC
 - 6. Johnson Controls Incorporated
 - 7. Schneider Electric
 - 8. Brady Trane
 - 9. Seimens

D. Owner Preferred Alternate No. OP-M1: Provide DDC controls by Honeywell Building Technologies, subject to compliance with the requirements of the specifications.

1.08 INTERNET ACCESS

- A. All information exchanged over the Internet shall be encrypted and secure via SSL (provided by owner).
- B. Access to the web interface shall be password protected. Provide all necessary security software to create a minimum of three levels and sufficient firewall protection. Read only command privileges shall be set by the

system administrator.

- C. Commissioning of the Web interface shall not require modification or creation of HTML or ASP pages. All graphics shall be available to users via a web browser.
- D. The web-based interface shall provide the following functionality to users, based on their access and privilege rights.
 - 1. Logon Screen: allows the user to enter their username, password, and Domain name for logging into the web saver. Access to be limited based on security level.
 - 2. Alarm Display: a display of current alarms to which the user has access will be displayed. Users will be able to acknowledge and reset active alarms, and link to additional alarm information including alarm messages and informational and memo text.
- E. Internet connections, ISP services, as well as necessary firewalls or proxy servers shall be provided by the Owner as required to support the web access feature. The Ethernet communication protocols of the new system must be fully compatible with the owner's Ethernet communication specifications. The contractor shall coordinate with the Town of Carrboro's Project Manager to obtain written approval to operate on the owner's network.
- F. The Town of Carrboro will provide LAN access points for the system's internet access.

PART 2 - PRODUCTS

2.01 MICROPROCESSOR BASED CONTROL SYSTEM FOR ENERGY MANAGEMENT

- A. General Requirements: Furnish and install a networking microprocessor-based Energy Management System (MPS) for the monitoring and control of the mechanical and electrical equipment designated. It is the intent of this specification to describe the performance requirements of the MPS. Therefore, these specifications describe the operational functions of the system and present minimal requirements for equipment to accomplish these functions. The MPS shall be comprised of the hardware and the software required to perform all designated tasks as described hereinafter. The installation may consist of one or more individual MPS panels. The term MPS refers to each individual panel as well as the entire installation. An MPS shall be able to communicate with other MPS by local network through BACnet IP wiring. A local network may be comprised of more than thirty (30) MPS. The local network shall be able to interface through the Web via an Ethernet port. The MPS system shall be a true distributive processing system and each MPS shall be a self-contained programmable control and monitoring system. Each MPS shall be able to perform its control, energy management and alarm functions independently from other units. The MPS shall consist of one or more logic panels depending upon control strategy and number of points controlled and/or monitored. The MPS shall not be dependent upon a master unit or CPU for control logic or data. The failure of one MPS shall not adversely affect the operation of other MPS of the distributed network.
- B. Hardware:
 - 1. Each MPS controller shall be UL listed or shall comply with UL 916 standard for Energy Management. Power Supply to the panel shall be isolated with UL labeled Class II transformer. The primary side of the transformer shall be protected by overcurrent protection, and the secondary side shall have fused disconnect. Circuit breaker type disconnect at the secondary side will not be acceptable. Primary side protection shall not be required on small Application Specific Controllers (ASC's) used to control small individual pieces of equipment (exhaust fans, fan coil units, etc.) The MPS shall be provided as a networking stand-alone energy management system enclosed in one or more sturdy metal enclosures containing a microcomputer, separate peripheral ports for connecting a laptop, a network communications port, power supplies, battery backup, and input/output control boards. Each MPS shall be able to gather information and/or update a minimum of four (4) times a second. All stand-alone units shall be accessible via the network through peripheral ports on the network units following proper password access code entry. All peripheral communication as well as global data transfer between network units shall be

accomplished through the local network. For owner-operator independence, the microcomputer shall be completely field-programmable through integral keyboard entries or through laptop computers.

- C. Status Indication: Annunciator light for each load, indicating controlled equipment operation. The MPS shall include a 24-hour time-of-day clock with standard calendar and full battery backup maintaining clock, building operating program and RAM memory for a minimum of thirty hours. A built-in charging circuit shall maintain battery at a full charge. All network units in the local network shall synchronize their time-of-day clocks every 24 hours. Each network port on the network shall allow access and programming to each of the other MPS units. A separate access code is to be maintained for each MPS unit. All system memory shall be programmable through these network ports and data entered into memory shall be recalled and displayed for operator review. Additions or deletions shall be made when the system is on-line. Systems requiring shutdown of any part shall not be acceptable. The programs and data sets, once entered into the MPS shall be capable of being stored on an external storage device (e.g. USB storage drive) through an on-site memory dump process and therefore be available to the operator for reloading as needed. The MPS supplier shall provide the necessary parts and external storage devices needed for this purpose. Check sum verification shall insure data integrity during loading operation. The MPS input/output hardware shall be compatible with electronic HVAC control systems for total building optimization, energy management and facilities management, such as abnormal condition alarm reporting. The MPS shall be capable of communication through the internet via an Ethernet link provided in the building. The MPS shall be furnished with a user programmable language and sufficient internal memory to provide at least the following software capabilities:
1. electric demand limiting
 2. time programmed commands to include two state and setpoint control
 3. duty cycle control
 4. optimum start-up control
 5. holiday scheduling
 6. time of day
 7. password entry
 8. direct digital control with P.I.D
 9. any other programs specified in the Input/Output schedule.
- D. Surge and Lightning Protection Line Voltage Protection: The DDC system control panels shall be powered by 120 VAC circuits provided with surge protection. This protection is in addition to any internal protection provided by the manufacturer. The protection shall be a TE/100 manufactured by Advanced Protection Technologies or an approved equal. Line voltage protection shall not be required on small Application Specific Controllers (ASC's) used to control small individual pieces of equipment (exhaust fans, fan coil units, etc.).

2.02 NETWORK PROVISIONS

- A. Virtual Local Area Network (VLAN): Provide a minimum 100 MB/second Ethernet VLAN capable of connecting a local control system server, operator workstations, and multiple Java Application Control Engines (JACE's). The VLAN shall support XML internet protocol, Hypertext Transfer Protocol (HTTP), Simple Object Access Protocol (SOAP), Java, BACnet and LonWorks.
- B. Local Area Network (LAN): Provide a minimum 100 MB/second Ethernet LAN which shall comply with IEEE Standard 802.3 and use 100 Base-TX, UTP-8 wire, Category 5 enhanced or 6 (Cat 5e or Cat 6) cabling.
- C. Remote Access: The VLAN shall be accessible without proprietary software by commonly available web browsers (i.e. Microsoft Edge, Google Chrome, Mozilla Firefox and Apple Safari) with tiered username and password security access.
1. Internet Access: The Owner shall provide high-speed internet connection for access to the VLAN. The Owner shall provide temporary secured access, for the duration of the project through the one-year walk-through, to the VLAN users.

2.03 MOBILE DEVICE APPLICATIONS

- A. EMCS shall provide the capability of remote interface via mobile applications for Android and iOS platforms. The application for mobile platforms shall provide real-time access to monitored inputs, setpoints, modes, values, statuses, and outputs.
 - 1. Operator interface shall consist of:
 - a. An icon-based, interactive application for Android and iOS devices.
 - b. Standard Android and iOS navigation methods shall be used to access, edit, and modify controller functions and shall be used to navigate through menus, select options and icons, and change parameters.
 - 2. Operator interface shall, at a minimum, have the following functions:
 - a. Points: The operator interface shall provide points list menus to view the inputs, setpoints, and output values such as hardware inputs/outputs, analog values, binary values, and multistate values.
 - 1) The points lists menus shall allow the operator to monitor, set, and override controller points and values.
 - 2) A color-code shall be used to indicate the conditions and statuses of points displayed in the points list menus.
 - b. Alarms: The operator interface shall provide a controller's alarms menu to view details of an alarm, to acknowledge the alarm, and to view the alarm history.
 - 1) The alarm menu shall allow the operator to view the following type of alarms: active not acknowledged, active acknowledged, and inactive not acknowledged.
 - 2) The combination of an icon and its color state shall notify the operator of an alarm condition.
 - 3) The operator shall be able to select a single point in alarm to view further details such as the alarm to/from status, current status, event date and time, alarm event threshold, and alarm event value.
 - c. Overrides: The operator interface shall provide an overrides menu to view a list of the controller's overridden points such as hardware input, hardware output, value, constant, or variable. The menu shall allow the operator to select an overridden point and to modify or release the override on the selected point.
 - d. PID loops: The operator interface shall provide a PID Loops menu to view, configure, and adjust the PID parameters. The interface shall also provide visual PID tuning with live system response graphing (live-trend).
 - e. Favorites: The operator interface shall allow access to a list of bookmarked points.
 - f. Weather: The operator interface shall provide a weather menu to view the current weather conditions with a weather status icon. The units shall be configured to be displayed in either metric or US units.
 - g. Password Protected: The controller operator interface shall provide multi-level password protection, with user-defined, alphanumeric, name/password combinations. The operator interface shall return to lock mode after a user- defined log-off delay. A password icon shall indicate the lock mode state.
 - h. Settings: The operator interface shall provide a settings menu to view and configure date and time parameters such as the current time, time zone, and daylight savings time.

2.04 GENERAL APPLICATION PROGRAMS

- A. Each stand-alone networking unit shall be programmable through the integral keyboard or peripheral

terminal. Software architecture shall allow both standard setups of point types, EMS Programs, loops or related parameters as well as custom program linking with math and logic. In addition, the MPS shall allow the building operators a means of interrogating input/output sensor conditions, such as interrogating the values of analog sensor input upon request, or the status of control via the standard keyboard and display unit. The MPS shall not be dependent upon a master control unit or CPU for control logic or data. The system access shall be restricted by at least three levels of password security. As a minimum, the system shall be programmed for six users each with designated three letter Operator ID and four- character password.

- B. Each of the MPS units on the network shall be able to access global information. Such information as outside air temperature, demand shed commands, and enthalpy changeover etc. routines can be shared by all units on the Network.
- C. Network data shall be capable of being trended from each MPS on the network for printout and alarm through locally connected printers on the network.
- D. Local Network status shall monitor all communication in the network. Loss of any data transfer will trigger alarms as well as default sequences to maintain system integrity. MPS will execute a pre-defined mode of operation if the system fails.
- E. Building alarm monitoring and reporting shall be generated based upon the presence of abnormal alarm conditions such as high/low temperature input or abnormal change of state such as freeze stats, fire stats, filter alarm switches, etc. Printed report upon alarm condition shall be generated and reported to designated terminal via Local Network System.

2.05 SPECIFIC APPLICATION PROGRAMS

- A. Electric Demand Limiting (EDL): The MPS shall contain a sliding window program and shall be programmed to reduce the peak demand for consumption and demand as user definable target values are approached. The MPS shall have the capability to do this although no electric demand sequences are included in this project.
- B. The EDL program shall automatically shed non-critical deferrable loads, on the network, such as electric heating coils, lights, battery chargers, HVAC systems, motors, etc., as outlined in the schedule, during high electrical usage periods. This sequence shall automatically restore the loads after a critical demand period has passed. The program should also have the capability of restoring loads based on any other data. This data could consist of time of day, outdoor or space temperatures, etc. The operator shall have the ability to select either the rolling (first off, first on) or the sequential (last off, first on) load shed tables for load assignment. Each load shall have its own minimum on, maximum off and minimum off time.
- C. The EDL program shall be capable of providing proportional voltage outputs which will change setpoints of HVAC control systems, and/or reset hot water or limit the number of operating compressors. Target demand limits shall be user definable.
- D. The EDL program shall be provided with a minimum of three times of day shifts, each containing unique KW target setpoints. These times of day target shifts will allow the target to be changed in accordance with the utility time of day metering schedule, such that during off hours EDL will allow a higher KW demand, if required, without being penalized for additional demand charges. The time of start and finish for each of the three times of day target values shall be user definable. Trend log may be programmed to store for future recall, the peak demand value, the day of month of occurrence and the time of day of occurrence.

2.06 TIME PROGRAMMED COMMANDS (TPC)

- A. The MPS system shall provide automatic start-up and/or shutdown of selected remote equipment and automatic adjustment of setpoint data according to pre-set schedules stored in the computer. All remote fans, pumps, motors, lights, HVAC systems, boilers, chillers, etc. or any device which operates on a preset time basis can be assigned to this program.

- B. TPC shall operate in accordance with a yearly calendar with automatic adjustment for daylight savings time and leap year.
- C. TPC shall incorporate holiday schedules capability which will automatically bring up predefined holiday schedules of operation. Holidays can be scheduled up to one year in advance and shall be capable of any number of holidays per year. The technique for scheduling holiday operation shall be to specify the date of the beginning day of the holiday and the date of the ending day of the holiday. For each of those days specified as a holiday, the time clock will follow its unique holiday schedule.
- D. TPC shall provide time dependent programmable two state control. This time program shall contain unique schedules which may be defined with appropriate start/stop times for each piece of controlled equipment. There should not be any limitation of number of schedules or number of start/stop per schedule. In addition to the time dependent two state control, TPC shall also provide time dependent setpoint control. This control provides the capability of outputting proportional setpoint values of a pre-determined, pre-defined setting in accordance with the time of day and day of week. This program shall be used to accomplish night setback, morning warm-up, and normal daily operating setpoints of all control system loops, controlled by the MPS.
- E. As with the two-state control, time dependent setpoint control shall be subject to the holiday schedule. The setpoints desired shall be user definable. The operator shall be capable of reading and/or altering all stored data pertaining to time of day, day of week, on/off times, setpoint values, and holiday designation.

2.07 OPTIMUM START PROGRAM (OS)

- A. The optimum start-up time of assigned equipment shall be determined based on a software calculation which takes into consideration outdoor air conditions, space conditions, and building R factor. Any or all zones and their associated loop control shall be capable of being optimized by the optimum start program. The software program shall be capable of precisely determining the ideal start-up time in the heating and cooling system. Each zone being optimized may have its own unique set of variables, such as temperature and occupancy time.
- B. The optimum start program shall control the start-up of the HVAC cooling and heating equipment to achieve the target occupancy space temperature at the precise time of building occupancy. By use of a local terminal device, i.e. laptop, the operator shall have the ability to program the occupancy time and target temperature for each zone to be optimized. A unique built-in "learning" technique shall allow the MPS to automatically adjust itself to the most effective time to start equipment in order to achieve the desired occupancy target temperature. Each zone being optimized shall have its own learning curve.

2.08 CUSTOM CONTROL

- A. The MPS shall utilize real-time calendar year time functions. The processor shall be able to evaluate seconds, minutes, hours, days of week, days of month, and years. The MPS shall make an automatic adjustment for leap years. The battery back-up shall accurately maintain all time functions in the event of power loss. The MPS software shall allow individual programmability of each load as well as coordinated control of loads within one MPS, as well as between different MPS. The MPS software must be of a user programmable type which will permit the user/operator easy communication with the processor. The MPS software shall provide an editing feature so that the user can enter control programs as well as alter, delete, or add to control programs. The MPS software shall provide a control simulation feature thereby allowing the user to pre-test the system software prior to, or while external wiring connections are being made to the system. The system shall have the ability to perform the following pre-tested control algorithms:
 1. Two-position control
 2. Proportional control
 3. Proportional plus integral control
 4. Proportional, integral, plus derivative control
 5. Automatic loop tuning

- B. The MPS software must make available elapsed seconds and minute timers for use in control software. Such timers will provide for the elimination of equipment short cycling.
- C. The MPS software must be structured in such a manner as to allow the user to develop his own user programs to fit the energy management and control strategy needs of the specific installation at hand. The MPS software must use a straightforward English format. The MPS software must have the capability of performing program control strategies based upon any or all analog and digital inputs and/or outputs within the specific MPS, or via the intercommunications lines, any or all analog and digital inputs and/or outputs from different MPS units. The MPS must have a programmable Daylight Savings Time feature which is user definable.
- D. The MPS shall allow the user to input full English identifications of all digital inputs, analog inputs, digital outputs, analog outputs, and counters. When the printout of data is requested, the full English identification will be printed with the data. The user shall be able to directly identify equipment status, system operation, digital and analog input data, without the need to reference tables or wiring diagrams.
- E. The MPS shall be able to perform special priority actions and strategies upon return of power after a power loss at the facility.
- F. The MPS software shall have the capability to execute control strategies based upon Boolean logic statements. The MPS software shall execute full addition, subtraction, multiplication, division, greater-than, less-than, and equals-to statements. The MPS shall also be able to process "and", "or", and "else" logic functions in the determination of control sequences.
- G. The MPS shall support an expanded math area where the user may input numeric values, decimal and negative numbers, and mathematical expressions. The MPS shall therefore allow the user to input user defined formulas for proportional, integral and derivative control including combinations of these controls. The MPS shall be able to utilize stored number values and the calculated values of user-defined formulas in the execution of the control strategies. The conversion of analog and digital information to customer-defined engineering units shall include, and not be limited to, KWH, %RH, GPM, CFM, etc.
- H. The MPS software shall be capable of performing special control strategies and alarming based upon occurrence of one or more emergency conditions such as equipment failure and temperature, pressure, flow or humidity readings which are determined by the processor to be out of a pre-determined range. The user must have the ability to adjust the emergency conditions at any time.
- I. The MPS software shall be capable of scheduling hours of occupancy for a full year in advance. The software must have the capability of scheduling 20 or more holiday schedules and vacation periods. Such events must be user-adjustable. The user shall have the capability of adjusting such events at any time.
- J. The MPS software shall employ internal machine diagnostics and parity checks to detect hardware or software faults. Upon itemization of such failure, the MPS shall shut down in a fail-safe manner as described hereinafter.
- K. Alarming Requirements:
 - 1. All alarms shall be immediately displayed.
 - 2. The networking microprocessor-based Energy Management System, hereinafter referred to as MPS, shall have the capability of storing and configuring alarms from a particular building or panel to be displayed when a particular user logs into the system at the laptop computer, or via the web browser.
 - 3. The MPS shall have the capability to initiate an alert to service personnel.
 - 4. The sending of the alarm report may be activated by user-defined "out of limits" conditions as determined by the input and output data to the MPS.
 - 5. The alarm report shall be user-definable and will include the facility identification, the specific MPS identification, time of alarm activation and the alarm condition. Each MPS shall maintain up to 16 different alarm reports.

6. The MPS shall also store the time of alarm activation and the time at which the alarm is cleared in its data file.
7. Each MPS of the distributed processing network shall have the capability to activate the sending of an alarm report.
8. The operator shall have the capability of deciding the alarm levels that shall be automatically printed.

L. Control Points:

1. Output: As required to perform control function outlined in the system description hereinafter. The processor shall be capable of expanding the output control points as required for future growth.

2.09 DIRECT DIGITAL CONTROL (DDC)

- A. Direct control capability using a custom control program, manual command, or time program-initiated commands shall be provided as a standard feature of this system. The Digital Output board shall be used for two state commands to loads, such as stop/start, day/night, open/close, etc. The digital output board shall provide a normally closed or open dry contact output with a minimum contact rating of 1 amp at 24 volts. The Digital Input board shall accept an input voltage of 0 to 2V for OFF and 10 to 24V for an ON, which can represent status or alarm signals from monitored devices or can count pulses from an energy demand generator. The Analog Input board shall accept 1 to 11 volts or 4 to 20 ma dc. Analog inputs shall be scaled to readout in engineering units, as appropriate. The Analog Output board shall be used for varying outputs (4-20 mA, 0-20 VDC, etc.) used for controlling modulating valves, dampers, etc.
- B. Inclusion above does not constitute automatic pre-qualification. Suppliers still must prove that they meet the specifications.

2.10 SENSORS AND TRANSMITTERS

- A. Space Temperature Sensors shall be electronic type. Accuracy of the transmitter shall be plus or minus 0.5 deg. F, at ambient temperature 77 deg. F. Sensors shall have a temperature range of -40 to 160 deg. F. Sensors shall have setpoint adjustment, manual override switch, display, and communication port allowing access to the entire network.
- B. Outdoor Air Temperature Sensor shall be mounted in the outdoors on the north side of the building where natural air flow occurs, away from any artificial affect from mechanical sources. The temperature range shall be - 40 to 220 deg. F. A sun shield and weatherproof assembly for mounting to 1/2-inch rigid conduit must be provided.
- C. Outdoor Air Humidity Sensor shall be mounted in the outdoors on the north side of the building where natural air flow occurs, away from any artificial affect from mechanical sources. Outdoor air humidity sensors shall have a sensing range of 20%-100% RH and shall be suitable for ambient conditions of 40°C-75°C (40°F-170°F). Humidity sensors shall not drift more than 1% of full scale annually.
- D. Humidity sensors shall be thin-film capacitive type sensor with on-board nonvolatile memory, accuracy to plus or minus two percent (2%) at 0 to 90% RH, 12 - 30 VDC input voltage, analog output (0 - 10 VDC or 4 - 20mA output). Operating range shall be 0 to 100% RH and 32 to 140 degrees F (0 to 60 degrees C). Sensors shall be selected for wall, duct or outdoor type installation as appropriate.
- E. Differential Liquid Pressure Switches shall be piped in parallel across all water circuits for positive indication of flow. Snap action SPDT switches shall operate from a neoprene slack diaphragm, corrosion-resistant stainless-steel diaphragm, or copper diaphragm capable of being adjusted through the total pressure range.
- F. Duct Temperature Sensors shall have an insertion measuring probe 6 inches long with a temperature range of -40 to 250 deg. F. The sensor shall include a utility box and gasket to prevent leakage and vibration noise. For all mixed air and preheat air applications, install bendable averaging duct sensors with a minimum 5-foot-long sensor element.

- G. Water Temperature Sensors shall have a temperature range of -40 to 250 deg. F. Provide brass or stainless steel thermowells and install sensor probe with heat conductive grease. Probe and sensor shall be removable without breaking fluid seal. Install sensors in top of pipe for horizontal runs to prevent condensation from flowing to sensor head.
- H. Differential Air Pressure Switches shall be piped in parallel across fans for positive indication of flow. Static pressure sensing tips shall be used for both high & low inputs. Pressure range shall be adjustable between .07 and 1.0" W.C. Snap acting contact shall be rated at 300 VA at 120 VAC.
- I. Differential Pressure and Pressure Sensors: Sensors shall have a 4-20 mA output proportional signal with provisions for field checking. Sensors shall withstand up to 150% of rated pressure, without damaging the device. Accuracy shall be within 2% of full scale.
- J. Pressure Switches: Pressure switches shall have a repetitive accuracy of $\pm 2\%$ of range and withstand up to 150% of rated pressure. Sensors shall be diaphragm or bourdon tube design. Switch operation shall be adjustable over the operating pressure range. The switch shall have an application rated Form C, snap-acting, self-wiping contact of platinum alloy, silver alloy, or gold plating.
- K. Space CO2 Sensor: The wall mounted Carbon Dioxide (CO2) sensor shall be contained in a decorative housing. The CO2 sensor shall use non-dispersive infrared (NDIR) technology and shall have integral programming to perform automatic baseline calibration without user interface. Sensor to be gold-plated. The recommended manual recalibration period shall not be less than five years. The CO2 range shall be 0-2000 PPM $\pm 5\%$ and ± 50 PPM, with analog outputs of 4-20 ma or 0-10 v. The power source shall be 18-30VAC, 50/60 Hz. The accuracy shall be ± 30 PPM + 2% of reading. Operating temperature 32-122F. Operating humidity 0% to 95% RH noncondensing. Sensor shall be located as shown on the plans and mounted approximately 60" above the floor.

2.11 CONTROL AND COMPUTER INTERFACE RELAYS

- A. Relays shall be plug-in type with blade type terminals (not pin type). Relays shall be furnished with separate relay base for ease of serving. Relays shall be furnished with SPDT, DPDT, 3PDT or 4PDT configuration as may be required. Relays shall have a minimal contact rating of 10 amps at 240 volts. Relay mechanical life expectancy shall be rated for 50,000,000 or more operations.
- B. Coil resistance shall be low VA type.

2.12 ELECTRIC DAMPER AND VALVE ACTUATORS

- A. Size electric actuators to operate their appropriate dampers or valves with sufficient reserve power to provide smooth modulating action or two-position action as specified. Where two or more actuators are to be operated in sequence to each other, provide position feedback positive positioners with adjustable start point and operating range.
- B. Stall Protection. Mechanical or electronic stall protection shall prevent actuator damage throughout the actuator's rotation.
- C. Spring-Return Mechanism. Actuators used for power-failure and safety applications shall have an internal mechanical spring-return mechanism or an uninterruptible power supply (UPS).
- D. Signal and Range. Proportional actuators shall accept a 0-10 Vdc or a 0-20 mA control signal and shall have a 2-10 Vdc or 4-20 mA operating range.
- E. Wiring. 24 Vac and 24 Vdc actuators shall operate on Class 2 wiring.
- F. Manual Positioning. Operators shall be able to manually position each actuator when the actuator is not powered. Non-spring-return actuators shall have an external manual gear release. Spring-return actuators with more than 7 N·m (60 in.-lb) torque capacity shall have a manual crank.

G. Operator bodies shall be metal.

2.13 CONTROL DAMPERS (Where dampers are not an integral part of the equipment and are furnished by DDC Contractor)

A. Type. Control dampers shall have linear flow characteristics and shall be parallel- or opposed-blade type as specified below or as scheduled on drawings.

1. Outdoor and return air mixing dampers and face-and-bypass dampers shall be opposed-blade and shall direct airstreams toward each other.
2. Other modulating dampers shall be opposed-blade.
3. Two-position shutoff dampers shall be parallel- or opposed-blade with blade and side seals.

B. Frame. Damper frames shall be 2.38 mm (13 gauge) galvanized steel channel or 3.175 mm (1/8 in.) extruded aluminum with reinforced corner bracing.

C. Blades. Damper blades shall not exceed 20 cm (8 in.) in width or 125 cm (48 in.) in length. Blades shall be suitable for medium velocity (10 m/s [2000 fpm]) performance. Blades shall be not less than 1.5875 mm (16 gauge).

D. Shaft Bearings. Damper shaft bearings shall be as recommended by manufacturer for application, oil impregnated sintered bronze, or better.

E. Seals. Blade edges and frame top and bottom shall have replaceable seals of butyl rubber or neoprene. Side seals shall be spring-loaded stainless steel. Blade seals shall leak no more than 50 L/s·m² (10 cfm per ft²) at 1000 Pa (4 in. w.g.) differential pressure. Blades shall be airfoil type suitable for wide-open face velocity of 7.5 m/s (1500 fpm).

F. Sections. Damper sections shall not exceed 125 cm - 150 cm (48 in. - 60 in.). Each section shall have at least one damper actuator.

G. Linkages. Dampers shall have exposed linkages. The shaft to which the actuator is coupled shall be square or hexagonal or round with one side flattened.

2.14 CONTROL VALVES

A. Factory fabricated type, body material, and pressure class based on maximum pressure and temperature rating of piping system, unless otherwise indicated.

B. Type. Provide two- or three-way control valves for two-position or modulating service as shown.

C. The manufacturer shall warrant all components for a period of 5 years from the date of production, with the first two years unconditional.

D. Characterized Control Valves

1. NPS 2" and Smaller: Nickel-plated forged brass body rated at no less than 400 psi, stainless steel ball and blowout proof stem, female NPT end fittings, with a dual EPDM O-ring packing design, fiberglass reinforced Teflon seats, and a TEFZEL flow characterizing disc. (NPS 3/4" and smaller for Terminal Units: Nickel plated forged brass body rated at no less than 600 psi, chrome plated brass ball and blowout proof stem, female NPT end fittings, with a dual EPDM O-ring packing design, fiberglass reinforced Teflon seats, and a TEFZEL flow characterizing disc.
2. NPS 2-1/2" and 3": GG25 cast iron body according to ANSI Class 125, standard class B, stainless steel ball and blowout proof stem, flange to match ANSI 125 with a dual EPDM O-ring packing design, PTFE seats, and a stainless-steel flow characterizing disc.
3. Sizing:

- a. Two-position: Line size or size using a pressure differential of 1 psi.
 - b. Three-Way Modulating: Twice the load pressure drop, but not more than 5 psig.
- 4. Close-Off Pressure Rating: 100 PSI. (NPS ¾” and Smaller for Terminal Units: 200 PSI.)
 - 5. The actuator shall be the same manufacturer as the valve, integrally mounted to the valve at the factory with a single screw on a four-way DIN mounting base.
- E. Fail Position. Water valves shall fail normally open or closed as follows unless otherwise specified.
 - 1. Water zone valves: normally open.
 - 2. Heating coils in air handlers: normally open.
 - 3. Chilled water control valves: normally closed.

2.15 ENCLOSURE

- A. The MPS shall be in a NEMA 1, 16-gauge steel cabinet. The cabinet door shall include a key lock latch and shall be made of steel with welded seams and corners. The cabinet shall contain sufficient terminal strips for input/output wiring and an enclosed block for connection of 120 volts, 60 Hz power. The I/O terminal shall be designed for easy installation of field cables. Terminal strips shall be clearly marked for ease of installation. The field breakdown of the panel must be possible without the need to disconnect the field wiring.

2.16 LABELS AND TAGS

- A. Provide labels for all field devices including sensors, meters, transmitters, and relays. Labels shall be plastic laminate and located adjacent to the device.
- B. Labels of field devices shall be associated with their respective air handler, pump, VAV box, etc.
- C. Junction box covers shall be painted blue and labeled “DDC”.
- D. VAV box label locations indicated on ceilings shall be printed on plastics acetate with adhesive backing.

PART 3 - EXECUTION

3.01 STARTUP

- A. Calibrate and adjust all control equipment and place systems into operation. All instrument calibrations shall be traceable to NIST. This shall include a systematic point-by-point checkout and operational check of all control devices with particular attention to the following:
 - 1. Tag all equipment involved with this contract with permanent bakelite lamichord tags. Stick-on type labels will not be acceptable.
 - 2. Check calibration of all sensing devices.
 - 3. Verify that all devices are wired properly and sensing or controlling as desired.
 - 4. Check out sequence of all equipment in all operating modes.
 - 5. Set clock for proper operation.
 - 6. Program the system with initial schedules and setpoints after discussions with the Owner.

3.02 SYSTEM TESTING

- A. The contractor shall perform the following on-site testing once installation is complete. The contractor shall provide a report on all discrepancies/errors that were uncovered and corrected during the system testing to designer prior to final acceptance.
- B. A 100% field calibration of all sensors and equipment.
- C. Verification of each control point by comparing the control command and the field device.

- D. Temperature Sensors: Measure temperature with calibrated thermometer or temperature sensor. Touch or otherwise disturb the sensor to verify the sensor being measured is connected to the correct point. Verify operation of the manual override and manual adjustment where applicable.
- E. Pressure Sensors and Transducers: Verify offset and gain calibration of every device.
- F. Verify output operation of all relays and verify they are connected to the correct point.
- G. Valve and damper strokes: Verify valve and damper stroke as compared to as-builts. Verify software stroke data corresponds with actual valve and damper strokes.
- H. Provide graphical trends of all setpoint control, both PID, two position, and floating. Verify PID loops have been “loop tuned”.
- I. Verify each Sequence of Operation using simulation mode. If simulation is not possible, provide trends of all points associated with each equipment system and trends of all global data to sufficiently and properly verify system operation.

3.03 INSPECTIONS

- A. The controls contractor shall perform startup and system testing prior to calling for an inspection by the Engineer. Minor corrections may be pointed out and made during the Engineer’s initial inspection. **If major corrections are needed, and the Engineer has to make additional site visits to inspect the system, then the controls contractor shall pay for the additional site visits.**

3.04 SYSTEM DEMONSTRATION

- A. The controls contractor shall demonstrate that controls are installed, adjusted and operate as required by the drawings and specifications. This demonstration shall be documented and shall be conducted in conjunction with Town of Carrboro personnel training. The documentation shall identify the item, the person performing the demonstration, the date, and the signature of the Town of Carrboro representative. The representative will select the items to be demonstrated. Items shall be demonstrated as follows:
 1. Disconnect one DDC from the building network to demonstrate that a single device failure will not disrupt peer-to-peer communication.
 2. Manually generate alarms at 10% of the installed alarmed points and demonstrate that the alarms are received.
 3. Provide documentation that calibration has been performed on 100% of the sensors.
 4. Provide point-to-point verification of 25% of all points. Include labeling of all points.
 5. Demonstrate the complete sequence of operation for air handling systems.
 6. Demonstrate the complete sequence of operation of the HVAC controls system during a fire alarm.
 7. Demonstrate the complete sequence of operation for 25% of VAV terminal units.
 8. Demonstrate graphics system is functional and the layout is consistent with field conditions.
 9. Demonstrate response to upset conditions and change of setpoint for all major systems for items 5 and 6 listed above.

3.05 TRAINING

- B. The manufacturer and the controls contractor shall provide on-site training in the maintenance and operation of the installed system for up to six (6) personnel. The training shall be documented and a syllabus and O&M manuals shall be submitted and approved by designer two (2) weeks prior to the training. The training shall include the following:
 1. HVAC systems layout including the locations of chiller, boiler, air handler, DDC controllers, VAV boxes, pumps, etc. This will include a walk-thru of the building.
 2. Sequence of Operation for each control loop.
 3. Accessing the control system including:

- a. Logon procedure.
 - b. Use of graphic and DDC pages.
 - c. Password requirements.
4. Operation and troubleshooting including:
- a. Modification of setpoints and schedules.
 - b. Overview of graphics and text pages.
 - c. Trending of points.
 - d. Calibration and adjustment.
 - e. Hands on training in troubleshooting and replacement of components including sensors, transmitters, control valves and actuators. Contractor shall have examples of each component and demonstrate measurement of input and output signals, and any operator adjustments available.
 - f. DDC controller functions and operation.
- C. The controls contractor shall provide an additional on-site training session nine (9) months after project completion. The purpose of the session will be to review any operation problems that have developed. In addition, the contractor will lead Town of Carrboro personnel through a comprehensive annual preventative maintenance of the controls system. This shall be scheduled at least one (1) month in advance.

3.06 GENERAL REQUIREMENTS

A. Control Wiring:

- 1. Control wiring shall be minimum 18 gauge.
 - 2. All line voltage control wiring shall be in conduit. All low voltage control wiring shall be in conduit in walls, mechanical rooms and where exposed. Conduit shall be run parallel or perpendicular to wall and building lines. Junction box covers shall be painted blue and labeled "DDC".
 - 3. Wires shall be labeled with mechanically prepared labels at their connection point to each apparatus point of connection.
 - 4. Wiring shall not use voice/data wire way/conduit systems as pathways.
 - 5. Plenum cable shall only be used in concealed locations above ceilings and shall be neatly routed on J-hooks.
- B. Install temperature sensors and manual overrides at locations shown on the drawings. All sensors and control devices intended to be adjusted by building occupants shall be mounted with their top located at 48" AFF.
- C. Manual overrides shall switch systems from unoccupied mode to occupied mode for a programmable length of time. Activation of the manual override for a particular system shall automatically bring on and control all other equipment needed by the system. This will include all needed hot water generators, chillers, pumps, etc.
- D. Provide alarms and trend logs as detailed in the Input / Output Schedules shown on plans. The points shown in the Input / Output Schedule are the minimum points to be provided. The Contractor shall provide additional Input / Output points, as required, to provide the performance described in this section and sequences of operation shown on plans.
- E. In the event of an MPS failure, all systems controlled by the particular MPS panel shall fail in the occupied mode of operation.
- F. Equipment serving a specific building zone shall be run according to the zone's own occupancy schedule. The Owner shall provide initial occupancy schedules for each zone to the Contractor. The Contractor shall include each specific zone schedule in the initial programming of the MPS. The Owner shall have the capability of modifying these schedules whenever desired.
- G. Laminate one copy of the panel layout and install in pouch in each control panel.

- H. Provide graphical programming of the system, including automatically updating graphic screens that

demonstrate building conditions and the operation of each piece of equipment and system.

- I. Upon startup of the system, the maintenance personnel of the Town of Carrboro shall be provided with four (4) hours of a planned and progressively advanced on-site training by a factory trained manufacturer's representative on the operation and maintenance of the DDC Control System. System startup time shall not apply toward this training time.

3.07 SEQUENCE OF OPERATION

- A. The Contractor shall examine the Sequence of Operation in the contract documents and advise the Engineer of any anticipated problems in programming the sequence and submit specific recommendations for modifying the sequence. The Contractor shall participate in discussions with the Owner and Engineer to develop the final Sequence of Operation. It shall be the contractor's responsibility to program the sequence and make any necessary changes for proper and optimal system performance. The Contractor shall use controllers that are capable of providing the full final sequence of operation for each particular application. Any installed controllers that are demonstrated not to have that full capability shall be replaced by the Contractor with the appropriate controllers.
- B. A meeting shall be scheduled prior to installation and programming of the DDC system between the controls subcontractor, engineer, and owner to refine control strategies and determine zoning and scheduling.

END OF SECTION 23 09 23

WATER PIPING SYSTEMS AND HYDRONIC SPECIALTIES

PART 1 - GENERAL

1.01 RELATED DOCUMENTS:

- A. Drawings, Standard General Conditions of the Construction Contract, including Supplementary General Conditions, Division 01 Specification sections and other Division 23 specification sections, apply to work of this section.

1.02 QUALITY ASSURANCE:

A. Codes and Standards:

- 1. ASME Compliance: Fabricate and install water piping in accordance with ASME B31.9 "Building Services Piping".

PART 2 - PRODUCTS

2.01 GENERAL:

- A. Provide pipes and pipe fittings complying with Section 23 21 60 in accordance with the following listings.
- B. Provide piping materials and factory-fabricated piping products of sizes, types, pressure ratings, temperature ratings, and capacities as indicated. Where not indicated, provide proper selection as determined by Installer to comply with installation requirements.

2.02 BASIC PIPES AND PIPE FITTINGS:

A. Heating Hot Water and Chilled Water Piping

- 1. Pipe Size 1-1/4" and smaller and where indicated: Type L copper, hard drawn temper wrought copper with soldered joints
- 2. Pipe Size 1-1/2" and larger and where indicated: Type L copper, hard drawn temper wrought copper with brazed joints.
- 3. Pipe Size 2" and Smaller: Black steel pipe; Schedule 40; Class 150 malleable iron fittings with threaded joints. May be used in mechanical rooms only.
- 4. Pipe Size 2-1/2" and Larger: Black steel pipe; Schedule 40; wrought-steel butt welding fittings with welded joints.
- 5. For underground piping, use corrosion-resistant cast flanges/fittings. (Comply with MSS-SP-51, including balling and gasketing).

B. City Water (Make-up) Piping, Domestic Cold Water:

- 1. Copper Tube Size 1-1/4" and smaller: Type L, hard drawn temper; wrought-copper fittings with soldered joints.
- 2. Copper Tube Size 1-1/2" and larger: Type L, hard drawn temper; wrought-copper fittings with brazed joints.

C. Condensate Drain Piping

- 1. Copper Type L, hard drawn, or Schedule 40 galvanized steel.

2.03 VALVES:

A. General: Provide valves complying with Section 23 05 23 as follows:

B. Sectional Valves:

1. 2-1/2 " and Smaller: Ball valves.
2. 3" and Larger: Butterfly valves.

C. Shutoff Valves:

1. 2-1/2" and Smaller: Ball valves.
2. 3" and Larger: Butterfly valves.

D. Drain Valves:

1. 2" and Smaller: Gate or ball valves.

E. Check Valves:

1. All Sizes: Swing or wafer check valves.

2.04 SPECIAL DUTY VALVES:

- A. Safety Relief Valves: 175 psig working pressure and 250 deg F maximum operating temperature; designed, manufactured, tested, and labeled in accordance with the requirements of Section IV of the ASME Boiler and Pressure Vessel Code. Valve body shall be cast-iron, with all wetted internal working parts made of brass and rubber. Select valve to suit actual system pressure and Btu capacity.
- B. Pump Discharge Valves (Triple Duty Valve): 175 psig working pressure, 250 deg F maximum operating temperature, cast iron body, bronze disc and seat, stainless steel stem and spring, and "Teflon" packing. Valves shall have flanged connections and straight or angle pattern as indicated. Features shall include non-slam check valve with spring loaded weighted disc, and calibrated adjustment feature to permit regulation of pump discharge flow and shutoff. The valve design shall permit repacking under full system pressure.

2.05 HYDRONIC SPECIALTIES:

- A. Manual Air Vent: Bronze body and nonferrous internal parts; 150 psig working pressure, 225 deg F operating temperature; manually operated with screwdriver or thumbscrew; and having 1/8 inch discharge connection and 2 inch inlet connection.
- B. Automatic Air Vent: Designed to vent automatically with float principle; bronze body and nonferrous internal parts; 150 psig working pressure, 240 deg F operating temperature; and having 1/4-inch discharge connection and 2 inch inlet connection.
- C. Y-Pattern Strainers: Provide strainers full line size of connecting piping, with ends matching piping system materials. Select strainers for 150 psig working pressure, cast-iron body (ASTM A 126, Class B), flanged ends for 2-1/2 inch and larger, threaded connections for 2 inch and smaller, bolted cover, perforated Type 304 stainless steel screen, and bottom drain connection.
- D. Pump Suction Diffusers: Cast iron body, with threaded connections for 2 inch and smaller, flanged connections for 2 1/2 inch and larger; 175 psig working pressure, 300 deg F maximum operating temperature; and complete with the following features:
 1. Inlet vanes with length 2 1/2 times pump suction diameter or greater.
 2. Cylinder strainer with 3/16 inch diameter openings with total free area equal to or greater than 5 times cross sectional area of pump suction, designed to withstand pressure differential equal to pump shutoff head.
 3. Disposable fine mesh strainer to fit over cylinder strainer.

4. Adjustable Foot Support designed to carry weight of suction piping.
5. Blowdown tapping in bottom; gage tapping in side.

PART 3 - EXECUTION

3.01 INSTALLATION OF PIPING:

- A. Install eccentric reducers where pipe is reduced in size in direction of flow, with tops of both pipes and reducer flush.
- B. Install supply piping with 1/32" per foot (1/4%) downward slope in direction of flow.
- C. Install return piping with 1/32" per foot (1/4%) downward slope in direction of flow.
- D. Connect branch-feed piping to mains at horizontal center line of mains, connect run-out piping to branches at horizontal center line of branches.
- E. Locate groups of pipes parallel to each other, spaced to permit applying full insulation and servicing of valves.
- F. Strainers on condenser water lines of pump suction lines shall be basket type. Strainers on all other water lines shall be Y-type. Run blow-off lines to nearest drain.

3.02 INSTALLATION OF VALVES:

- A. Sectional Valves: Install on each branch and riser, close to main, where branch or riser serves 2 or more hydronic terminals or equipment connections, and elsewhere as indicated.
- B. Shutoff Valves: Install on inlet and outlet of each mechanical equipment item, and on inlet of each hydronic terminal, and elsewhere as indicated.
- C. Drain Valves: Install on each mechanical equipment item located to completely drain equipment for service or repair. Install at base of each riser, at base of each rise or drop in piping system, and elsewhere where indicated or required to completely drain hydronic piping system.
- D. Check Valves: Install on discharge side of each pump, and elsewhere as indicated.

3.03 EQUIPMENT CONNECTIONS:

- A. Connect piping to mechanical equipment as indicated and comply with equipment manufacturer's instructions where not otherwise indicated. Install shutoff valve and union on supply and return, drain valve on drain connection. Install dielectric unions for all connections of ferrous pipe to non-ferrous pipe.

3.04 INITIAL CLEANOUT

- A. After system checkout, clean out entire system prior to extended operation. This cleanout operation shall include replacement of all disposable strainers and cleaning of all strainers and dirt legs. Provide all necessary chemicals for initial cleanout based on equipment manufacturer's recommendation. Refer to Sections 23 21 60, 23 25 00, and "Installation Instructions for 30RAP Chiller" for additional requirements.
- B. Systems Set Up for Extended Operation
 1. After initial cleanout is complete, set up all systems with required amounts of chemicals based on the water analysis of make-up water.

END OF SECTION 23 20 10

PART 1 - GENERAL

1.01 RELATED DOCUMENTS AND RELATED WORK SPECIFIED ELSEWHERE:

A. Related Documents

1. Drawings, Standard General Conditions of the Construction Contract, including Supplementary General Conditions, Division 01 Specification sections, and other Division 23 specifications apply to work of this section.

1.02 Codes and Standards:

- A. HI Compliance: Design, manufacture, and install hydronic pumps in accordance with HI "Hydraulic Institute Standard".
- B. UL Compliance: Design, manufacture, and install hydronic pumps in accordance with UL 778 "Motor Operated Water Pumps".
- C. SUBMITTAL:
- D. Manufacturer's Data: Submit manufacturer's pump specifications, installation and start-up instructions, and current accurate pump characteristic performance curves with selection points clearly indicated.

PART 2 - PRODUCTS

2.01 FLEXIBLE COUPLED END SUCTION PUMPS

- A. Pumps shall be base-mounted, single-stage, end suction design with a foot mounted volute to allow removal and service of the entire rotating assembly without disturbing the pump piping, electrical motor connections or pump to motor alignment.
- B. Pump volute shall be cast iron with integrally-cast pedestal support. The impeller shall be cast stainless-steel enclosed type, dynamically balanced, and keyed to the shaft by a locking cap screw or nut.
- C. The liquid cavity shall be sealed off at the pump shaft by an internally-flushed mechanical seal with ceramic seal seat and carbon seal ring, suitable for continuous operation at 250 deg. F. A replaceable stainless-steel shaft sleeve shall completely cover the wetted area under the seal.
- D. Pumps shall be rated for minimum of 175 psi working pressure. Casings shall have gauge ports at suction and discharge nozzles and vent and drain ports at top and bottom of casing.
- E. Pump bearing housing assembly shall have heavy-duty regreasable ball bearings, replaceable without disturbing piping connections and have foot support at coupling end.
- F. Base plate shall be of structural steel or fabricated steel channel configuration with fully enclosed sides and ends, and securely welded cross members and fully open grouting area. The combined pump and motor baseplate shall be sufficiently stiff as to limit the susceptibility of vibration. The minimum baseplate stiffness shall conform to ANSI/HI 1.3.8.2.1-2009 for grouted Horizontal Baseplate Design standards.
- G. A flexible-type, center drop-out design coupler, capable of absorbing torsional vibration, shall be employed between the pump and motor, and it shall be equipped with an OSHA-compliant coupling guard. Pumps for

variable speed application shall be provided with a suitable coupling sleeve. Contractor to level and grout each unit according to manufacturer's instructions.

- H. The motor shall be premium efficiency, TEFC type, and meet NEMA specifications and shall be the size voltage and enclosure called for on the plans. Pump and motor shall be factory aligned, and shall be realigned by contractor per factory recommendations after installation.
- I. Each pump selected shall conform to ANSI/HI 9.6.3.1-2012 standards for Preferred Operating Region (POR) unless otherwise approved by the engineer. Each pump shall be factory hydrostatically tested per Hydraulic Institute standards. It shall then be thoroughly cleaned and painted with at least one coat of high-grade machinery enamel prior to shipment.
- J. Each unit shall be checked by the contractor and regulated for proper differential pressure, voltage and amperage draw. This data shall be noted in the test and balance report, and on a permanent tag or label and fastened to the pump for owner's reference.
- K. Basis of design pumps are ITT Bell and Gossett e-1510 2BD and e-1510 1.5AD. Refer to pump schedule on drawings.
- L. End suction pumps shall be Series "e1510" as manufactured by ITT Bell and Gossett, Grundfos, Taco, Weinman, Armstrong or approved equal.

2.02 ACCESSORIES

- A. Where noted on the HVAC Pump Schedule provide suction diffusers. Suction diffusers shall be by the pump manufacturer.

PART 3 - EXECUTION

3.01 INSTALLATION OF PUMPS:

- A. Install pumps in strict accordance with manufacturer's instructions to avoid any stress and misalignment.
- B. Install base mounted pumps on concrete housekeeping base. Each unit shall be leveled and grouted according to the manufacturer's instructions before alignment and start-up.
- C. Where pump connection size and indicated line sizes are not identical, provide necessary concentric reducers/increasers for vertical piping at pump connection and eccentric reducers/increasers for horizontal piping at pump connection. Install eccentric reducers/increasers with top of pipe level to avoid air pockets. All valves and piping specialties shall be full line size as indicated on drawings.
- D. Anywhere that 5 straight pipe diameters of pipe cannot be provided on the inlet side of a pump a suction diffuser shall be used to provide appropriate flow distribution into the eye of the pump's impeller.
- E. All piping shall be brought to pump connections in such a manner as to prevent the possibility of any loads or stresses being applied to the connections or piping. All piping shall be fitted to the pumps even though piping adjustments may be required after the pipe is installed.
- F. Each unit shall be leveled according to the manufacturer's instructions before alignment and start-up.
- G. The associated adjustable speed drive shall be used to balance the pump flow for the chilled water pump. Impellor shall not be trimmed. For the chilled water pump, the test and balance contractor shall determine the speed required for the desired flow and the ASD shall be set to run at that speed.

- H. For the hot water pump, pull and trim the pump impeller after a proportional balance has been done by the balance contractor. Hydronic systems shall be balanced in a manner to first minimize throttling losses; then the pump impeller shall be trimmed. A balance report from the installer shall be furnished to the Engineer and a copy included in the operating and maintenance manual.
- I. Power and control wiring shall be run in separate conduits.
- J. Provide access space around HVAC pumps for service as indicated, but in no case less than that recommended by the manufacturer.
- K. Align and lubricate pumps before start-up. The Contractor shall provide laser alignment services for all pumps with couplers. A written report shall be provided for each pump regarding its laser alignment.

3.02 STARTUP

- A. Start-up in accordance with manufacturer's instructions.
- B. Verify that piping system has been flushed, cleaned and filled.
- C. Prime pump, vent air from casing and verify that rotation is correct. To avoid damage to mechanical seals, never start or run pump in dry condition.
- D. Perform field mechanical balancing, if necessary, to eliminate excessive vibration.

END OF SECTION 23 21 23

PART 1 - GENERAL

1.01 RELATED DOCUMENTS:

Drawings, Standard General Conditions of the Construction Contract, including Supplementary General Conditions, Division 01 Specification sections and other Division 23 specification sections, apply to work of this section.

1.02 DESCRIPTION OF WORK:

- A. Materials, equipment and work specified in this Section apply to the work specified in other sections of Division 23.

1.03 QUALITY ASSURANCE:

- A. Codes and Standards:
 - 1. Welding: Qualify welding procedures, welders and operators in accordance with ASME Boiler and Pressure Vessel Code, Section IX, for shop and project site welding of piping work. Owner reserves the right to perform nondestructive testing of welded pipe joints by radiographic inspection whether or not explicitly required by code.
 - 2. Owner reserves the right to utilize any testing procedure listed in Chapter VI ASME B31.1 to verify structural integrity of any weld(s) not meeting Engineer's approval. If integrity of weld(s) is found to be in compliance with ASME B31.1, Owner will pay for the additional testing cost. If weld(s) is found to be deficient, contractor shall be responsible for all costs associated with the testing and repair of the weld(s).

PART 2 - PRODUCTS

2.01 GENERAL:

Where called for in the scope or where shown in drawings, use applicable products from those specified below. All pipes shall be American-made.

- A. Piping Materials: Provide pipe and tube of type, joint type, grade, size and weight (wall thickness or Class) indicated for each service. Where type, grade or class is not indicated, provide proper selection as determined by Installer for installation requirements, and comply with governing regulations and industry standards.
- B. Pipe/Tube Fittings: Provide factory-fabricated fittings of type, materials, grade, class and pressure rating indicated for each service and pipe size. Provide sizes and types matching pipe, tube, valve or equipment connection in each case. Where not otherwise indicated, comply with governing regulations and industry standards for selections, and with pipe manufacturer's recommendations where applicable.

2.02 STEEL PIPES AND PIPE FITTINGS:

- A. Applications: Chilled Water, Heating Hot Water, Condensate Drains.
- B. Carbon Steel Pipe: Schedule 40 (minimum) ASTM A 53 for piping 4" and larger, galvanized steel pipe, or copper pipe listed below.
- C. Malleable-Iron Threaded Fittings: ANSI B16.3; plain or galvanized as indicated.
- D. Malleable-Iron Threaded Unions: ANSI B16.39; selected by Installer for proper piping fabrication and

service requirements, including style, end connections, and metal-to-metal seats (iron, bronze or brass); plain or galvanized as indicated.

- E. Threaded Pipe Plugs: ANSI B16.14.
- F. Steel Flanges/Fittings: ANSI B16.5, including bolting and gasketing of the following material group, end connection and facing, except as otherwise indicated.
 - 1. Material Group: Group 1.1.
 - 2. End Connections: Buttwelding; weldneck flanges.
 - 3. Facings: Raised-face.
- G. Forged-Steel Socket-Welding and Threaded Fittings: ANSI B16.11, except MSS SP-79 for threaded reducer inserts; rated to match schedule of connected pipe.
- H. Pipe Nipples: Fabricated from same pipe as used for connected pipe; except do not use less than Schedule 80 pipe where length remaining unthreaded is less than 1-1/2", and where pipe size is less than 1-1/2", and do not thread nipples full length (e.g., no close-nipples).

2.03 COPPER TUBE AND FITTINGS:

- A. Applications: Chilled Water, Heating Hot Water, Makeup Water.
 - 1. ASTM B88 Copper Tubing – Type (wall thickness) L, hard or soft temper as specified. Wrought copper, cast copper, or cast bronze solder or brazing joint type fittings.
- B. Applications: Condensate Drains:
 - 1. ASTM B88 or ASTM B 306 Copper Tubing – Type (wall thickness) L, hard or soft temper as specified. Wrought copper or cast copper solder joint type fittings.
- C. Specifications:
 - 1. Copper Tube: ASTM B 88.
 - 2. DWV Copper Tube: ASTM B 306.
 - 3. Cast-Copper Solder-Joint Fittings: ANSI B16.18.
 - 4. Wrought-Copper Solder-Joint Fittings for 2-1/2" and smaller: ASTM B-88 ANSI B16.22.
 - 5. Cast Bronze for 3" and larger: ASTM B-62.
 - 6. Cast-Copper Solder-Joint Drainage Fittings: ANSI B16.23.
 - 7. Wrought-Copper Solder-Joint Drainage Fittings: ANSI 16.29.
 - 8. Cast-Copper Flared Tube Fittings: ANSI B16.26.
 - 9. Bronze Pipe Flanges/Fittings: ANSI 16.24.
 - 10. Wrought Copper and Copper Alloy Brazed Joint Fittings: ASTM B 50.
 - 11. Copper Tube Unions: Solder type, cast bronze, ground joint, 150 PSI SWP. Provide standard products recommended by manufacturer for use in service indicated.

2.04 PLASTIC PIPE AND FITTINGS:

- A. Applications: Only where specifically called for on the drawings.
- B. Polyvinyl Chloride Pipe (PVC): ASTM D1785, Schedule 40 or Schedule 80 as indicated for each service.
- C. PVC Fittings:
 - 1. Schedule 40 Socket: ASTM D 2466.
 - 2. Schedule 80 Socket: ASTM D 2467.
 - 3. Schedule 80 Threaded: ASTM D 2464.

4. Solvent Cement: ASTM D 2564.

2.05 MISCELLANEOUS PIPING MATERIALS/PRODUCTS:

- A. Welding Materials: Except as otherwise indicated, provide welding materials to comply with Section II, Part C, ASME Boiler and Pressure Vessel Code for welding materials.
- B. Pipe Joint Compound: Blue, Black or equal.
- C. Pipe Thread Compound - Garlock. Teflon tape may be used. Oil or lead not permitted.
- D. Soldering Materials: Except as otherwise indicated, provide soldering materials as follows:
 - 1. Tin-Antimony Solder: ASTM B 32, Grade 95TA. For pipe size 1-1/4" & under.
 - 2. Brazing Alloy: Silver 15%, copper 80%, phosphorous 5%. For pipe size 1-1/2" and larger.
 - 3. Gaskets for Flanged Joints: ANSI B16.21; raised-face for steel flanges, unless otherwise indicated.

2.06 DISSIMILAR PIPE UNIONS:

- A. Piping Connectors for Dissimilar Non-Pressure Pipe: Elastomeric annular ring insert, or elastomeric flexible coupling secured at each end with stainless steel clamps, sized for exact fit to pipe ends and subject to approval by plumbing code.
- B. Piping Connectors for Dissimilar Pressure Pipe (Dielectric Union):
 - 1. General: Provide standard products recommended by manufacturer for use in service indicated, which effectively isolate ferrous from non-ferrous piping (electric conductance), prevent galvanic action, and stop corrosion.

PART 3 - EXECUTION

3.01 INSTALLATION:

- A. General: Install pipes and pipe fittings in accordance with recognized industry practices which will achieve permanently-leakproof piping systems, capable of performing each indicated service without piping failure. Install each run with minimum joints and couplings, but with adequate and accessible unions for disassembly and maintenance/replacement of valves and equipment. All 90-degree elbows shall have long radius. Two 45-degree elbows in lieu of one 90-degree elbow are not permitted where short elbows are used. Reduce sizes (where indicated) by use of reducing fittings. Align piping accurately at connections, within 1/16" misalignment tolerance. Comply with ASME B31 Code for Pressure Piping.
- B. Locate piping runs, except as otherwise indicated, vertically and horizontally (pitched to drain) and avoid diagonal runs unless such routing is clearly indicated on the drawings. Orient horizontal runs parallel with walls and column lines. Locate runs as shown or described by diagrams, details and notations or, if not otherwise indicated, run piping in shortest route which does not obstruct usable space or block access for servicing building and its equipment. Hold piping close to walls, overhead construction, columns and other structural and permanent-enclosure elements of building. Provide manual air vents at all high points in the piping. Provide a system drain and 1/2" drain cocks at all low points in the piping to allow complete system drainage. All vent and drain piping within the mechanical room shall run down the wall to the floor drain with shut-off ball valves located four feet above the ground. All other vents shall be piped to a nearby location facing downwards.
- C. Provide unions at final connections to all equipment. Use reducing fittings when changing pipe sizes.
- D. Grade condensate drain lines 1/8 inch per foot.
- E. Insulating Unions - Required wherever piping of different material is joined.

3.02 PIPING SYSTEM JOINTS:

- A. Thread pipe in accordance with ANSI B2.1; cut threads full and clean using sharp dies. Ream threaded ends to remove burrs and restore full inside diameter. Apply pipe joint compound, or pipe joint tape (Teflon) where recommended by pipe/fitting manufacturer, on male threads at each joint and tighten joint to leave not more than 3 threads exposed.
- B. Solder copper tube-and-fitting joints where indicated, in accordance with recognized industry practice. Cut tube ends squarely, ream to full inside diameter, and clean outside of tube ends and inside of fittings. Apply solder flux to joint areas of both tubes and fittings. Insert tube full depth into fitting, and solder in manner which will draw solder full depth and circumference of joint. Solder condensate drain joints with 95 5 tin antimony solder, Fed. Spec. QQ S 5716 and non-corrosive flux. Acid flux not allowed. Wipe excess solder from joint before it hardens.
- C. Copper to Screwed - Cast bronze to iron adaptor with insulating gasket.
- D. Black Steel Screwed (above ground) - malleable iron fittings.
- E. Weld pipe joints in accordance with ASME B31.1 or ASME B31.9, as applicable. Welded joints shall be subject to non-destructive testing at the Owner's discretion and expense, which shall consist of 100% visual, and 10% UT or radiographic. If all pass then no additional testing will be required. If any fail, then additional testing will be paid for by the contractor until all joints pass.
- F. Welding: Pipe welding in sizes 2 inches and smaller may be either by the Manual Metallic Arc Process or the Oxyacetylene Welding Process, and in sizes larger than 2 inches shall be by the Manual Metallic Arc Process with coated electrodes. All welding of steam piping shall be done in conformance with Chapter V of the latest edition of the ASME Code for Power Piping B31.1.
 - 1. Operators who are to do the welding must be properly qualified to do satisfactory work. All field welding shall be done by welders qualified in the 6G position. Proof of an operator's qualifications shall be either the Contractor's record of suitable tests passed within the preceding 90 days while in the employ of the Contractor, or maintaining his qualifications by welding at least every 90 days since last test. Any workman considered by the Engineer as not having the skill necessary for the work shall be required to pass an appropriate qualification test or shall be at once barred from further welding on the job.
 - 2. Joints shall be properly beveled, thoroughly cleaned of rust or other foreign matter, and degreased before welding. Metallic arc-welding electrodes shall conform to ASTM A233. Oxyacetylene welding rods shall be commercial steel gas welding rods and shall conform to ASTM A251, GA60.
- G. All piping connections shall be with pre-manufactured fittings (T, elbow, etc.) or with "weldolets," "threadolets" or "sockolets." This includes instrumentation such as thermometer wells, etc.
 - 1. "Weldolets" with outlet size 2-1/2" and larger and "Threadolets" or "Sokolets" with outlet size 2" and smaller may be used for branch takeoff up to one half (1/2) diameter of main. Use "Threadolets" where threaded fittings are specified and use "Sokolets" where socket weld fittings are specified. Materials of "Weldolets" and "Threadolets" shall match material of piping.
 - 2. Mitered ells, welded branch connections, notched tees and "orange peel" reducers are not allowed. Unless specifically indicated, reducing flanges and reducing bushings are not allowed.
- H. Flanged Joints: Match flanges within piping system, and at connections with valves and equipment. Clean flange faces and install gaskets. Tighten bolts to provide uniform compression of gaskets.

3.03 CLEANING, FLUSHING, INSPECTING:

- A. General: Clean exterior surfaces of installed chilled and heating hot water piping systems of superfluous materials and prepare for application of specified coatings (if any). Flush out piping systems with clean water before proceeding with required tests. Flush system with water until it runs clean. Introduce pre-treatment

cleaning chemical as indicated in Section 23 25 00 – Water Conditioning. Fill, vent, and circulate system until all chemical has been removed. Follow manufacturer’s recommendations for concentration and disposal of chemical. Drain and refill system. Clean all strainers, check valves, etc. before refilling. Inspect each run of each system for completion of joints, supports and accessory items.

- B. Inspect pressure piping in accordance with procedures of ASME B31.1 or ASME B31.9, as applicable. Owner reserves the right to perform radiographic inspections of welded joints in pressure piping.

3.04 PIPING TESTS:

- A. Test pressure piping in accordance with ASME B31.1 or ASME B31.9, as applicable. Minimum test pressure shall be 1-1/2 times the normal operating pressure or 100 psi, whichever is greater, unless otherwise indicated. Test pressure shall be maintained for a minimum of 4 hours.
- B. Pressure change during test not to exceed 5% unless otherwise specified.
- C. Remove, or otherwise protect from damage, all control devices, air vents and other parts not designed to withstand the test pressure.
- D. Notify Owner at least one week in advance of pressure test to allow for Owner observation. If Owner is not properly notified, contractor shall repeat pressure test in Owner’s presence.
- E. Repair any leaks and retest. Provide test report.
- F. Repair any leaks which develop during guarantee period.

END OF SECTION 23 21 60

PART 1 – GENERAL

1.01 RELATED DOCUMENTS:

- A. Drawings, Standard General Conditions of the Construction Contract, including Supplementary General Conditions, Division 01 Specification sections and other Division 23 specification sections, apply to work of this section.

1.02 DESCRIPTION OF WORK

- A. The water conditioning work shall consist of cleaning the chilled water and heating hot water systems, and providing water treatment for the chilled water and heating hot water systems.

1.03 QUALITY ASSURANCE:

- A. Water conditioning equipment and programs to control scale, corrosion, oxygen pitting and organic growth shall be provided. The contractor shall provide all testing, chemicals, maintenance, etc. from the date the equipment is started until one year after the final acceptance of each system. The chemicals used and feeding methods employed shall comply with all codes and with regulations of authorities having jurisdiction. Required permits for the disposal of waste from treated systems shall be obtained prior to the installation of equipment and the initiation of conditioning programs. A licensed and recognized water conditioning company shall provide supervision and service for all phases of water treatment consisting of field supervision for the cleaning and treatment of the systems, installation of feeding equipment, and operator training in the use of chemical feeding equipment.

1.04 SUBMITTALS:

- A. Manufacturer's Data: Submit manufacturer's technical product data, including SDS sheets, and installation instructions for water conditioning materials and products. Include data on chemical feed equipment, spare parts lists, chemicals, procedures, and treatment programs. Include step by step instructions on test procedures including target concentrations and values.

PART 2 - PRODUCTS

2.01 WATER TREATMENT FEEDERS

- A. Chemical Feeder: Bypass type chemical feeders of 5 gallon capacity, welded steel construction; 125 psig working pressure; complete with fill funnel and inlet, outlet, vent and drain valves.
 - 1. Chemicals shall be specially formulated to prevent accumulation of scale and corrosion in piping system and connected equipment, developed based on a water analysis of make-up water.

PART 3 - EXECUTION

3.01 GENERAL:

- A. Water conditioning installation shall be as specified herein and/or indicated schematically on the plans. The installation shall be complete with all required equipment, chemicals, material and appurtenances, whether or not specifically implied or expressed herein or indicated on the Drawings. Electrical work shall be done in accordance with Section 230530. Materials of construction of equipment furnished shall be suitable for the chemicals being handled and as indicated. Chemical piping and piping accessories shall be Schedule 80 or stainless steel as approved by the chemical manufacturer. Chemicals, feed and bleed equipment, and

supervision for water conditioning programs shall be provided by a recognized water conditioning company with qualified laboratory and field service facilities readily available to the site. This company shall provide all chemicals, test kits and reagents required for the period of time hereinbefore specified including initial dosage and supervision and service for all phases of the water treatment program including the following:

1. Field supervision and certification of initial flushing, cleanout, and filling.
2. Field supervision for the installation and for the injection of initial dosages of treatment in all systems.
3. The services of a qualified field representative on a regular basis to make complete on-the-spot water analysis of all systems. A written report of the findings will be left with the Owner, and confirmation reports will be forwarded to the Engineer. As a minimum, reports shall be submitted monthly. However, additional visits may be required during startup and during seasonal operational changes. As a minimum the following tests shall be performed and the results recorded on the raw make up water, and the water in the hot water system.

pH	TDS (Total Dissolved Solids)	Total Alkalinity
Hardness (total)	Hardness (CaCo3)	Chlorides
Silica	Iron	LSI

4. The contractor should also perform any additional tests, specific to his chemicals, to determine the quantity of treatment chemicals is satisfactory, or any tests that are necessary to fully determine whether the treatment program is adequate.
5. Approximately 30 days prior to the end of the guarantee period, the field representative shall completely analyze all water systems and take action to correct all discrepancies noted. A written report of his findings, including a description of all abnormalities and corrective action taken, shall be submitted to the Owner.

3.02 INITIAL CLEANOUT:

- A. **Contractor to flush and clean piping prior to connecting to new chiller, new chilled water pump, and new hot water pump.** For additional requirements, refer to “INSTALLATION INSTRUCTIONS FOR 30RAP CHILLER” which is included in the project manual.
- B. Contractor to furnish pre-cleaning chemicals for the cleaning of new and existing chilled water and heating hot water piping. Prior to extended operation and after the flushing operation specified in Section 232010, all new and existing piping and heat transfer equipment shall be chemically cleaned with a material especially formulated to remove oil, grease, mill scale and other foreign materials. Cleanout operation shall be performed according to manufacturer’s recommendations and under the supervision of the water conditioning company who shall perform all tests and submit written certification that the system is clean prior to acceptance of the installation.

3.03 CHEMICAL TREATMENT:

- A. Chemicals shall be specially formulated to prevent accumulation of scale and corrosion in piping systems and connected equipment, and to prevent organic growth developed based on a water analysis of make-up water, and in accordance with equipment manufacturer’s recommendations.

3.04 O&M MANUALS

- A. Include manufacturer's technical product data, including SDS sheets, and installation instructions for water conditioning materials and products. Include data on equipment, spare parts lists, chemicals, procedures, and treatment programs. Include step by step instructions on test procedures including target concentrations and values.

3.05 WARRANTY

- A. The manufacturer of the above specified equipment shall guarantee equipment of its manufacture, and

bearing its identification to be free from defects in workmanship and material for a period of 12 months for mechanical parts from date of delivery from the factory or authorized distributor under normal use and service and otherwise when such equipment is used in accordance with instructions furnished by the manufacturer and for the purposes disclosed in writing at the time of purchase, if any.

- B. In the event a component fails to perform as specified and having been returned to the manufacturer transportation charges prepaid, and is proven defective in service during the warranty period, the manufacturer shall repair or replace the defective part. Replaceable elastomeric parts and glass components are expendable and are not covered by any warranty.

END OF SECTION 23 25 00

**FOR REFERENCE – THE CARRIER MODEL 30RAP0605J-0KFC4 CHILLER WAS
PREPURCHASED BY THE OWNER AND IS TO BE INSTALLED IN THIS
CONTRACT**

AIR-COOLED SCROLL WATER CHILLERS

PART 1 - GENERAL

1.01 RELATED DOCUMENTS

Drawings, Standard General Conditions of the Construction Contract, including Supplementary General Conditions and Division-1 Specification sections, apply to work of this section.

1.02 SECTION INCLUDES

- A. Chiller package.
- B. Charge of refrigerant and oil.
- C. Controls and control connections.
- D. Chilled water connections.
- E. Starters.
- F. Electrical power connections.

1.03 REFERENCES

- A. ANSI/AHRI 590 - Positive Displacement Compressor Water - Chilling Packages.
- B. ANSI/AHRI 550 - Centrifugal or Rotary Water - Chilling Packages.
- C. ANSI/ASHRAE 15 - Safety Code for Mechanical Refrigeration.
- D. ANSI/ASHRAE 90A - Energy Conservation in New Building Design.
- E. ANSI/ASME SEC 8 - Boiler and Pressure Vessel Code
- F. ANSI/NEMA MG 1, 2, 3, 10 and 11: Standards for High Efficiency Motors.
- G. ANSI/UL 465 - Central Cooling Air Conditioners.
- H. ANSI/UL 984 - Safety Standard for Hermetic Motor Compressors.
- I. ANSI/AFBMA 9-1978 - Load Ratings and Fatigue Life for Ball Bearings. Bearings must have life of not less than L10 200,000 hours.
- J. ASTM B117 - Standard Method of Salt Spray (Fog) Testing
- K. ASTM A123 - Zinc (Hot-Dip Galvanized) Coatings on Iron and Steel Products
- L. ASTM A525 - Zinc (Hot-Dip Galvanized) Coatings on Sheet Steel Products

M. UL 1995 – Heating and Cooling Equipment

N. ASTM D1654 - Evaluation of Painted or Coated Specimens, Subjected to Corrosive Environments

1.04 SUBMITTALS

- A. Submittals of shop drawings and manufacturer’s data, etc. shall be provided to the Designers electronically in PDF format.
- B. Submit drawings indicating components, assembly, dimensions, weights and loadings, required clearances, and location and size of field connections. Indicate accessories where required for complete system.
- C. Submit product data indicating rated capacities, weights, specialties and accessories, electrical requirements and wiring diagrams.
- D. Summary of all auxiliary utility requirements such as electricity, water, etc. Summary shall indicate quality and quantity of each required utility.
- E. Single line schematic drawing of the field power hookup requirements, indicating all items that are furnished.
- F. Schematic diagram of control system indicating points for field interface/connection. Diagram shall fully delineate field and factory wiring.
- G. Submit manufacturer's installation instructions and qualifications of factory start up service person.

1.05 OPERATION AND MAINTENANCE DATA

- A. Submit operation data.
- B. Include start-up instructions, maintenance data, controls, and accessories.
- C. Submit maintenance data.

1.06 REGULATORY REQUIREMENTS

- A. Conform to ANSI/AHRI 590 Standard for testing and rating of Positive Displacement Compressor Water - Chilling Packages or conform to ANSI/AHRI 550 Standard for testing and rating of Centrifugal and Rotary Screw Water - Chilling Packages.
- B. Conform to ANSI/UL 465 or UL 1995 code for construction of water chillers. In the event the unit is not UL approved, the manufacturer shall, at his expense, provide for a field inspection by an UL representative to verify conformance to UL standards. If necessary, contractor shall perform modifications to the unit to comply with UL, as directed by the UL representative. Alternatively, the chiller may be ETL listed.
- C. Conform to ANSI/ASME SEC 8 Boiler and Pressure Vessel Code for construction and testing of water chillers.
- D. Conform to ANSI/ASHRAE 15 code for construction and operation of water chillers.
- E. Conform to NC Energy Conservation Code efficiency requirements for water-chilling packages as outlined in Table C403.2.3(7).

1.07 STORAGE AND HANDLING

- A. Comply with manufacturer's installation instructions for rigging, unloading, and transporting units.
- B. Protect units from physical damage. Factory coil shipping covers shall be kept in place until installation.
- C. Unit controls shall be capable of withstanding 203 Deg F (95 Deg C) storage temperatures in the control compartment for an indefinite period of time.

1.08 WARRANTY

- A. Warranty shall include parts and labor coverage for a period of one year from date of equipment start-up, or for a period of one year from 18 months after shipment, whichever occurs first.
- B. Extended Compressor Warranty: Four (4) years extended compressor warranty, including parts and labor.
- C. Refrigerant Warranty: One (1) year.
- D. Note: An Extended Warranty of 5 years of complete chiller coverage appears as an Alternate in section 01 23 00 SCHEDULE OF ALTERNATES.

1.09 MAINTENANCE SERVICE

- A. Furnish service and maintenance of complete assembly for one year from date of equipment start-up.

PART 2 - PRODUCTS

2.01 SUMMARY

- A. The Furnishing Contractor shall furnish a nominal 60-ton air-cooled water chiller as described in the table below and throughout this specification section. The chiller shall be installed by the Installing Contractor in accordance with this specification and perform at the specified conditions as scheduled.

REQUIRED ITEMS	DESCRIPTION
Minimum Cooling Capacity at AHRI Conditions	56.88 Tons
Power Rating	208V / 3 Phase / 60 Hz
Minimum EER at 100% Load	10.29 Btu/Wh
Minimum IPLV	15.17 Btu/Wh
Minimum Number of Refrigerant Circuits	2
Minimum Number of Compressors	3
Condenser Fans	Variable Speed on at Least One Fan
Compressor Staging	On/Off
Ability to Vary Water Flow	Shall be Able to Back Down to 33.4% of its Maximum Allowed Flow
Refrigerant	R410A or R32
Hail Guards	Provide for Condenser Coils

Strainer on Water Inlet	Provide Manufacturer's Recommended Type
Refrigerant Isolation Valves	Provide Isolation Valves For Each Compressor So Rest of Unit Can Remain Operational If One Compressor Has To Be Worked On
Insulation	Cold Parts of the Chiller Shall Be Insulated to Prevent Condensation In Humid Conditions And Parts Containing Water Shall Be Insulated And Heat Traced To Prevent Freezing
Acoustic Treatment	Provide Acoustic Blankets on Compressors
Vibration Isolation	Pad Type Isolators

- B. Furnish Daikin, Carrier, Trane, or York scroll compressor chillers. Equals MUST still comply with the performance, dimensions, and features as specified with these specifications and as indicated on the design documents.
- C. Unit must be run tested at the factory to confirm proper operation. Documentation of factory run test Certification is to be a final part of the submittal process.

2.02 GENERAL UNIT DESCRIPTION

- A. Provide factory assembled and tested outdoor air-cooled liquid chillers consisting of helical scroll compressors, condenser, evaporator, thermal or electronic expansion valve, refrigeration accessories, starter and microprocessor-based control panel. Construction and ratings shall be in accordance with ANSI/AHRI 550 or ANSI/AHRI 590. Unit shall have single point power connection.

2.03 COMPRESSORS

- A. Compressor/Compressor Assembly:
 1. The compressors shall be sealed hermetic, scroll type with crankcase oil heater and suction strainer. The compressor motor shall be refrigerant gas cooled, high torque, hermetic induction type, two-pole, with inherent thermal protection on all three phases and shall be mounted on RIS vibration isolator pads. The compressors shall be equipped with an internal module providing compressor protection and communication capability.

2.04 EVAPORATOR – EITHER TYPE IS ALLOWED

- A. SHELL AND TUBE
 1. Provide factory insulated shell and tube type evaporator, seamless or welded steel construction with cast iron or fabricated steel heads, seamless internally finned copper tubes, roller expanded into tube sheets.
 2. Design, test, and stamp refrigerant side for 300 psig (2068 kPa) working pressure and water side for 215 psig (1482 kPa) working pressure, in accordance with ANSI/ASME SEC 8.
 3. Insulate with 0.75 inch (20 mm) minimum thick flexible elastomeric rubber closed cell insulation with maximum K value of [0.28]. Provide heat tape to protect evaporator to -10°F (-23°C).
 4. Provide water drain connection, vent and fittings for factory installed leaving water temperature control and low temperature cutout sensors.
 5. Water connections shall be welded. Evaporator shall have only one entering and one leaving connection.

B. BRAZED PLATE-TO-PLATE

1. The evaporator shall be a compact, high efficiency, dual circuit, brazed plate-to-plate type heat exchanger consisting of parallel stainless-steel plates. Vent and drain connections shall be provided in the inlet and outlet chilled water piping by the installing contractor.
2. The evaporator shall be protected with an external, electric resistance heater plate. The evaporator and suction piping to the compressors shall be insulated with 3/4" (19 mm) thick CFC and HCFC-free closed-cell flexible elastomeric foam insulation material with 100% adhesive coverage. The insulation shall have an additional outer protective layer of 3mm thick PE embossed film to provide superior damage resistance. Insulation without the protective outer film shall not be acceptable. UV resistance level shall meet or exceed a rating of 'Good' in accordance with the UNI ISO 4892 - 2/94 testing method. This combination of a heater plate and insulation shall provide freeze protection down to -10°F (-23°C) ambient air temperature.
3. The water-side maximum design pressure shall be rated at a minimum of 435 psig (3000 kPa). Evaporators shall be designed and constructed according to and listed by Underwriters Laboratories (UL).

2.05 CONDENSER AND FANS

- A. Chiller shall be able to operate in ambient conditions down to 36 degrees F.
- B. Construct condenser coils of aluminum fins mechanically bonded to seamless copper tubing. Alternatively, a micro channel coil may be used. Provide sub-cooling circuits. Air test under water to 506 psig (3488 kPa).
- C. Provide factory painted and mounted louvered coil guards. Coil guards shall cover the condenser coils.
- D. Provide vertical discharge direct driven condenser fans with fan guard on discharge. Entire fan assembly shall be statically, and dynamically balanced and fan assembly shall be either painted or zinc coated steel. Provide variable speed control on all, or not less than one, of the condenser fans.
- E. The variable speed drives for condenser fans shall include a DC link reactor.
- F. Fans shall be protected by coated steel wire safety guards.

2.06 ENCLOSURES

- A. House components in heavy gauge galvanized steel frame and mounted on welded structural steel base. Hot-dip galvanized steel frame coating shall be Underwriters Laboratories Inc. (UL) recognized as G90-U, UL guide number DTHW2.
- B. Unit panels, louvered panels, and control panels shall be finished with a baked-on powder paint. Control panel doors shall have door stays. Paint system shall meet the requirements for outdoor equipment of Federal Government Agencies.
- C. Mount starters and disconnects in weatherproof panel provided with full opening access doors. Provide lockable through-the-door disconnect operating handle external to panel and clearly visible from outside of unit indicating if power is on or off.
- D. Casings fabricated from steel that do not have a Zinc coating conforming to ASTM A123 or ASTM A525 shall be treated for the prevention of corrosion with a factory coating or paint system. The coating or paint system shall withstand 500 hours in a salt-spray fog test in accordance with ASTM B 117. Each specimen shall have a standard scribe mark as defined in ASTM D 1654. Upon completion of exposure, the coating or paint system shall be evaluated and rated in accordance with procedures A and B of ASTM D 1654. The rating of failure at the scribe mark shall be not less than six (average creepage not greater than 1/8

inch). The rating of the unscribed area shall not be less than ten (no failure). Thickness of coating or paint system on the actual equipment shall be identical to that on the test specimens with respect to materials, conditions of application, and dry-film thickness.

2.07 REFRIGERANT CIRCUIT

- A. All units shall have a minimum of 2 refrigeration circuits, each with one or two (manifolded) compressors on each circuit.
- B. Provide for each refrigerant circuit:
 - 1. Liquid line shutoff valve.
 - 2. Filter dryer (replaceable core type).
 - 3. Liquid line sight glass and moisture indicator.
 - 4. Electronic expansion valve sized for maximum operating pressure.
 - 5. Charging valve.
 - 6. Discharge and oil line check valves.
 - 7. Compressor suction and discharge service valves.
 - 8. High side pressure relief valve.
 - 9. Full operating charge of R-410A, or R-32 and oil.
 - 10. Unit factory leak tested at 200 psig.

2.08 CONTROLS

- A. The chiller(s) shall be controlled by a stand-alone direct digital control (DDC) system. A dedicated Unit Control Module (UCM) with a touch screen interface is to be supplied with each chiller by the chiller manufacturer. The controller shall provide chiller capacity control in response to the leaving chilled water temperature.
- B. On chiller, mount weatherproof control panel containing starters and power and control wiring. Provide single point power connection on units with MCA less than 500 amps. Provide primary and secondary fused control power transformer and a single 115-volt single phase connection for evaporator heat tape.
- C. For each compressor, provide across-the-line starter on 460V applications or star-delta starter on 200-230V.
- D. Provide the following safety controls with indicating lights or diagnostic readouts.
 - 1. Low chilled water temperature protection.
 - 2. High refrigerant pressure.
 - 3. Low oil flow protection.
 - 4. Loss of chilled water flow.
 - 5. Contact for remote emergency shutdown.
 - 6. Motor current overload.
 - 7. Phase reversal/unbalance/single phasing.
 - 8. Failure of water temperature sensor used by controller.
 - 9. Compressor status (on or off).
- E. Safeties:
 - 1. Unit shall be equipped with thermistors and all necessary components in conjunction with the control system to provide the unit with the following protections:
 - a. Reverse rotation.
 - b. Low chilled fluid temperature.
 - c. Motor overtemperature.

- d. High pressure.
 - e. Electrical overload.
 - f. Loss of phase.
 - g. Loss of chilled water flow.
2. Condenser-fan motors shall have internal overcurrent protection.
- F. Provide the following operating controls:
- 1. Number of steps for leaving chilled water temperature control shall equal or exceed the number of compressors.
 - 2. Five-minute solid state anti-recycle timer to prevent compressor from short cycling. If a greater than 5-minute solid state anti-recycle timer is provided, hot gas bypass shall be provided to insure accurate temperature control in light load applications.
 - 3. Load limit thermostat to limit compressor loading on high return water temperature to prevent nuisance trip-outs.
 - 4. High ambient unloader pressure stat that unloads compressors to keep head pressure under control and help prevent high pressure nuisance trip-outs on days when outside ambient is above design.
 - 5. Compressor current sensing unloader unit that unloads compressors to help prevent current overload nuisance trip-outs.
 - 6. Auto lead-lag functions that constantly even out run hours and compressor starts automatically. If contractor cannot provide this function, then cycle counter and hour meter shall be provided for each compressor so owner can be instructed by the contractor on how to manually change lead-lag on compressors and even out compressor starts and running hours.
 - 7. Low ambient lockout control with adjustable setpoint.
 - 8. Condenser fan sequencing which automatically cycles fans in response to ambient, condensing pressure and expansion valve pressure differential thereby optimizing unit efficiency.
- G. Provide digital display of pressures/ temperatures on UCM.
- H. Provide ammeters for each compressor or digital display of % RLA on UCM.
- I. Manufacturer shall provide flow switches.
- J. The UCM shall seamlessly communicate and interface with the building automation system (BAS). The UCM shall be provided with a BACnet Translator Control or other equipment necessary for external communications utilizing BACnet interface or gateway. All hardware, software, documentation and operational parameters needed for this interface shall be provided. The interface shall provide the following communication points at a minimum, that can be read and, where applicable, controlled by the BAS:
- a. Remote enable / disable
 - b. Entering chilled water temperature
 - c. Leaving chilled water temperature
 - d. Chilled water temperature setpoint
 - e. Reset of chilled water temperature setpoint
 - f. Chiller status
 - g. Alarms
 - h. Clear alarm
 - i. Outside air temperature
- K. Chiller to output a start stop signal to the chilled water pump. This will be relayed by the DDC system to start the pump.
- L. Maximum Sound Generation Levels

1. A-Weighted Sound Pressure Levels (dB re 20 micropascals) calculated based upon a 30' horizontal distance, at full load, receiver at 3' above ground, shall not exceed 64 dBA.
2. Notes: (1) Measurements performed in accordance with AHRI Standard 370-2015 for air-cooled Chillers. Distance 30'.

M. Additional Features:

1. Variable Speed Condenser Fans:

One or more fans on the unit shall have variable speed fan motors to provide higher part load efficiency and reduced acoustic levels. Each such fan circuit shall have a factory-installed, independent variable speed drive with display. Variable speed drives shall have rated IP-55 enclosures and be UL Listed. Variable speed condenser fans also allow the chiller to operate at ambient temperatures as high as 125.6°F (52°C).

2. Unit-Mounted Non-Fused Disconnect:

Unit shall be supplied with factory-installed, lockable, non-fused electrical disconnect for main power supply.

3. Energy Management Module:

A factory installed module shall provide the following energy management capabilities: 4 to 20 mA signals for leaving fluid temperature reset, cooling set point reset or demand limit control; 2-step demand limit control (from 0% to 100%) activated by a remote contact closure.

4. Isolation Valve Option:

Unit shall be supplied with factory-installed isolation valve which provides a means of isolating the compressors from the evaporator vessel, which is beneficial in servicing the chiller.

5. Suction Line Insulation:

Unit shall be supplied with suction line insulation. Insulation shall be tubular closed-cell insulation. This option shall be required with applications with leaving fluid temperatures below 30°F (-1.1°C) and for areas of high dewpoints where condensation may be a concern.

6. Control Transformer:

Unit shall be supplied with a factory-installed transformer that will allow supply control circuit power from the main unit power supply.

7. GFI Convenience Outlet:

Shall be factory mounted and wired with easily accessible 115-v female receptacle. Shall include 4-amp GFI (ground fault interrupt) receptacle.

8. Hail Guards:

Unit shall be equipped with a factory-installed option consisting of louvered panels on the end and sides of the machine to cover and protect the condenser fins. These coverings shall firmly fasten to the machine frame.

PART 3 - EXECUTION

3.01 INSTALLATION

- A. Installing Contractor shall install in accordance with manufacturer's instructions.
- B. Align chiller package on steel or concrete foundations.
- C. Install units on pad type isolators per manufacturer's recommendations.
- D. Connect to electrical service.
- E. Connect to chilled water piping.
- F. Arrange piping for easy dismantling to permit tube cleaning for shell and tube models.
- G. Install flow switches in chilled water piping properly interlocked to ensure that unit can operate only when water flow is established.
- H. Furnish and install taps for thermometers and pressure gauges in water piping adjacent to inlet and outlet connections of unit.
- I. Provide and install drain valves to drain the chiller.

3.02 MANUFACTURER'S FIELD SERVICES

- A. Furnishing Contractor shall supply the services of factory trained representatives to test and start-up chiller. Test controls and demonstrate to engineer compliance with requirements. Replace damaged, or malfunctioning controls and equipment and retest. Do not place chillers in sustained operation prior to initial balancing of mechanical systems which interface with the chillers.
- B. Furnishing Contractor shall supply factory trained representative to provide two hours of instruction on operation and maintenance of the chiller to Owner. This shall not include time spent on chiller startup.
- C. Furnishing Contractor shall supply initial charge of refrigerant and oil.

3.03 MAINTENANCE MANUALS

- A. Maintenance Manuals shall be submitted in three (3) hard copies in vinyl 3-ring binders, and three (3) copies in electronic format as PDF files on disks. Each manual shall have the following:
 - 1. Service telephone number of the installing company, including an emergency number.
 - 2. Contact person, phone number, and address of manufacturer or distributor where equipment was purchased.
 - 3. The manufacturing company's operating and maintenance manuals for each piece of equipment.
 - 4. Copies of all approved shop drawings.
 - 5. Copies of warranties with their start dates.

END OF SECTION 23 64 23



Installation Instructions

CONTENTS

	Page
SAFETY CONSIDERATIONS	1
INSTALLATION	2
Storage Recommendations	2
Step 1 — Place and Rig the Unit	2
• PLACING UNIT	
• RIGGING	
• MOUNTING UNIT	
Step 2 — Check Compressor Mounting	18
Step 3 — Connect Cooler Fluid and Drain Piping	18
• ALL UNITS	
• VICTAULIC COUPLING INSTALLATION	
• UNITS WITH FACTORY-INSTALLED HYDRONIC PACKAGES	
• AIR SEPARATION	
Step 4 — Fill the Chilled Water Loop	34
• WATER SYSTEM CLEANING	
• FILLING THE SYSTEM	
• PUMP VFD	
• SENSORLESS CONTROL (CLOSED LOOP) — ACTIVE SETUP 1	
• REMOTE SENSOR (CLOSED LOOP) — ACTIVE SETUP 2	
• REMOTE CONTROLLER (OPEN LOOP) — ACTIVE SETUP 3	
• PREPARATION FOR YEAR-ROUND OPERATION	
• FREEZE PROTECTION	
• PREPARATION FOR WINTER SHUTDOWN	
Step 5 — Make Electrical Connections	45
• POWER SUPPLY	
• POWER WIRING	
• CONTROL POWER	
Step 6 — Install Accessories	67
• ELECTRICAL	
Step 7 — Check Refrigerant Circuit	67
• LEAK TESTING	
• DEHYDRATION	
• REFRIGERANT CHARGE	
BACnet Communication Option Wiring	68
APPENDIX A (PRESSURE DROP CURVES)	71

SAFETY CONSIDERATIONS

Installing, starting up, and servicing air-conditioning equipment can be hazardous due to system pressures, electrical components, and equipment location (roofs, elevated structures, etc.).

Only trained, qualified installers and service mechanics should install, start up, and service this equipment (Fig. 1).

Untrained personnel can perform basic maintenance functions such as cleaning coils. All other operations should be performed by trained service personnel.

When working on the equipment, observe precautions in the literature and on tags, stickers, and labels attached to the equipment.

- Follow all safety codes.

- Wear safety glasses and work gloves.
- Keep quenching cloth and fire extinguisher nearby when brazing.
- Use care in handling, rigging, and setting bulky equipment.

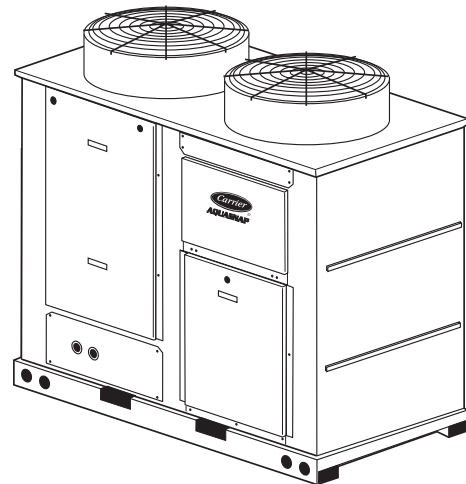

Fig. 1 — Typical 30RAP Unit (018-030 Shown)

⚠ WARNING

Electrical shock can cause personal injury and death. Shut off all power to this equipment during installation. There may be more than one disconnect switch. Tag all disconnect locations to alert others not to restore power until work is completed.

⚠ WARNING

DO NOT USE TORCH to remove any component. System contains oil and refrigerant under pressure.

To remove a component, wear protective gloves and goggles and proceed as follows:

- Shut off electrical power to unit.
- Recover refrigerant to relieve all pressure from system using both high-pressure and low pressure ports.
- Traces of vapor should be displaced with nitrogen and the work area should be well ventilated. Refrigerant in contact with an open flame produces toxic gases.
- Cut component connection tubing with tubing cutter and remove component from unit. Use a pan to catch any oil that may come out of the lines and as a gage for how much oil to add to the system.
- Carefully unsweat remaining tubing stubs when necessary. Oil can ignite when exposed to torch flame.

Failure to follow these procedures may result in personal injury or death.

⚠ CAUTION

DO NOT re-use compressor oil or any oil that has been exposed to the atmosphere. Dispose of oil per local codes and regulations. DO NOT leave refrigerant system open to air any longer than the actual time required to service the equipment. Seal circuits being serviced and charge with dry nitrogen to prevent oil contamination when timely repairs cannot be completed. Failure to follow these procedures may result in damage to equipment.

INSTALLATION

Storage Recommendations — The 30RAP air-cooled chillers are designed for outdoor installations. At times, a delay in construction or other factors require that a unit be stored for a period of time prior to installation. The following guidelines should be used for unit storage.

PROVIDE MACHINE PROTECTION — Place and store the unit in an area that will protect it from vandalism, accidental contact with vehicles, falling debris or construction waste. Ideally, do not remove the shipping protection such as the coil protectors. This will provide additional protection for the unit. The unit can be stored outdoors.

INSPECTION DURING STORAGE — To ensure faster installation when the time comes, the following inspection schedule is recommended:

Every 3 Months — The 30RAP units are shipped with a complete operating charge of R-410A. Check each refrigerant circuit to be sure that there is positive pressure, at least 26 psig (180 kPa) in the circuit. If a circuit is found to be without pressure, contact a qualified refrigeration mechanic. The system should be pressurized to find the leak. It should be repaired, dehydrated, and recharged with refrigerant. If a positive circuit pressure was not found, the compressor oil should be changed or at least sampled to determine if moisture is present. If moisture is found in the compressor oil, the oil should be changed.

Every 6 Months — Check the unit for damage, both physical and from wildlife. Check the unit for nests from rodents, birds, or insects. Depending on location, these organisms can cause deterioration of components which may result in failure. Consider an exterminator if necessary. If damage is found and it will interfere with the installation, consider repairing the damage before installation. Check the unit control box for signs of moisture. If moisture is found, determine the entry path and seal the leak.

Step 1 — Place and Rig the Unit

PLACING UNIT — Units are suitable for outdoor use only. For 30RAP011-060 units, see Fig. 2. When parallel chillers are aligned such that coils face each other, a minimum of 6 ft (1829 mm) separation is recommended. When the parallel arrangement has only one coil drawing air from the space between chillers, a minimum of 3.5 ft (1067 mm) is recommended. When parallel chillers have no coils facing each other (a back-to-back arrangement), be sure to maintain the larger of the recommended service clearances associated with each chiller (see the certified drawings). Due to NEC (National Electric Code) regulations, a minimum clearance of 4 ft (1219 mm) must be maintained on the side of the chiller that has an electrical box. Chiller fan discharge must be at least as high as adjacent solid walls. Installation in pits is not recommended.

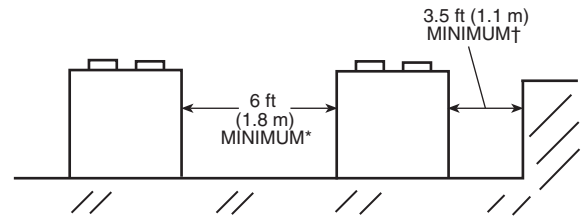

* Minimum for when coils face each other. Less clearance is required in other configurations.

† Clearance of 3.5 ft is required when a coil faces the wall. When there is no coil facing the wall, see the certified drawing for the required service clearance.

Fig. 2 — 30RAP011-060 Multiple Unit Separation

For 30RAP070-150 units, see Fig. 3. When chillers are arranged in parallel, a minimum of 10 ft (3048 mm) between chillers is recommended. Acceptable clearance on the cooler connection side or end opposite the control box of the unit can be reduced to 3 ft (1 m) without sacrificing performance as long as the remaining three sides are unrestricted. Acceptable clearance on the side with a control box can be reduced to 4 ft (1.3 m) due to NEC (National Electric Code) regulations, without sacrificing performance as long as the remaining three sides are unrestricted. Clearances between chillers in dual chiller applications may be reduced to 6 ft (1.8 m) without sacrificing performance provided the remaining sides are unrestricted. For acceptable clearance with layout involving more than 2 chillers, please contact application engineering.

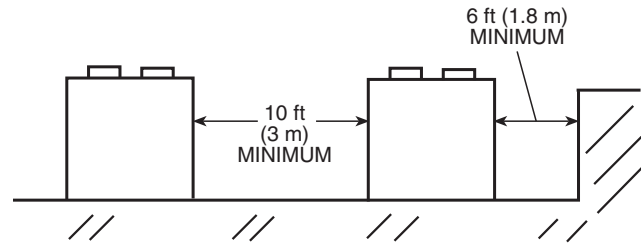

Fig. 3 — 30RAP070-150 Multiple Unit Separation

These instructions cover installation of 30RAP011-150 air-cooled liquid chillers. Refer to Fig. 4 and 5 for model number to determine factory-installed options.

RIGGING — Preferred method for rigging is with spreader bars from above the unit. Use shackles in lifting points. Rig at a single point with 4 cables for size 011-115 units, 6 cables for size 130 and 150 units, or use spread bars. All panels must be in place when rigging. See rigging label on unit for details concerning shipping weights, distance between lifting holes, center of gravity, and lifting ring dimensions. See Tables 1-3 and Fig. 6 for unit weights. See Tables 6 and 7 for physical data. See Fig. 7 and 8 for rigging label.

If overhead rigging is not possible, place chiller on skid or pad for rolling or dragging. When rolling, use a minimum of 3 rollers. When dragging, pull the pad. *Do not apply force to the unit.* When in final position, raise from above to lift unit off pad.

⚠ CAUTION

All panels must be in place when rigging. If they are not, damage to unit could result.

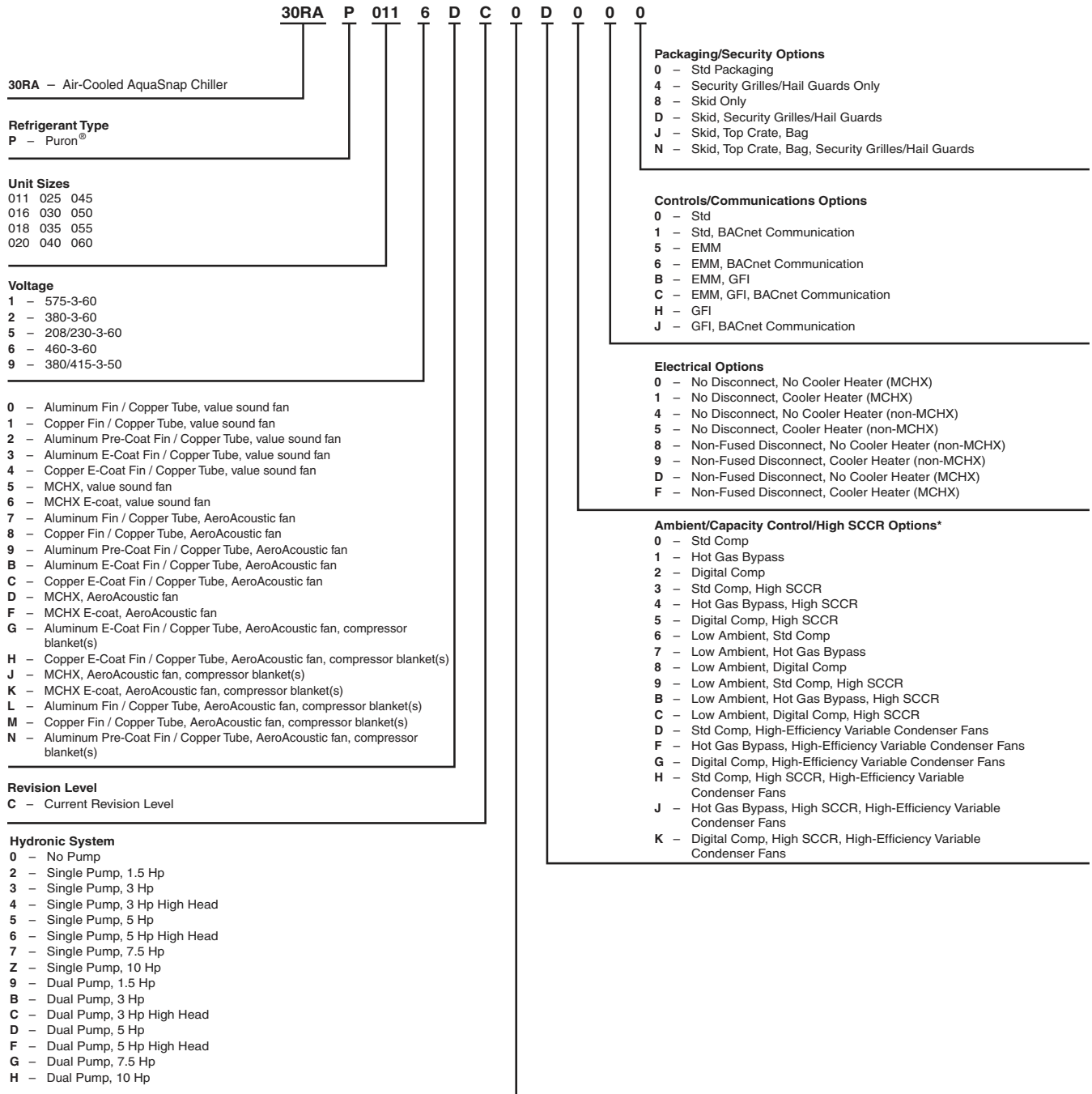

*High-efficiency variable condenser fans (codes D, F, G, H, J, and K) are the only choices for sizes 011 and 016.

LEGEND

- EMM** — Energy Management Module
- GFI** — Ground Fault Interrupting
- MCHX** — Microchannel Heat Exchanger
- SCCR** — Short Circuit Current Rating

Fig. 4 — AquaSnap® Chiller Model Number Designation, 30RAP011-060

30RA P 070 6 D B 0 6 0 0 0

30RA – Air-Cooled AquaSnap Chiller

Refrigerant Type

P – Puron®

Unit Sizes

070 115
080 130
090 150
100

Voltage

1 – 575-3-60
2 – 380-3-60
5 – 208/230-3-60
6 – 460-3-60
9 – 380/415-3-50

Condenser Coil and Low Sound Options

0 – Aluminum/Copper, Value Sound Fan
1 – Copper/Copper, Value Sound Fan
2 – Aluminum/Copper, Pre-Coat, Value Sound Fan
3 – Aluminum/Copper, E-Coat, Value Sound Fan
4 – Copper/Copper, E-Coat, Value Sound Fan
5 – MCHX, Value Sound Fan
6 – MCHX, E-Coat, Value Sound Fan
7 – Aluminum/Copper, AeroAcoustic™ Fan
8 – Copper/Copper, AeroAcoustic Fan
9 – Copper/Aluminum, Pre-Coat, AeroAcoustic Fan
B – Copper/Aluminum, E-Coat, AeroAcoustic Fan
C – Copper/Copper, E-Coat, AeroAcoustic Fan
D – MCHX, AeroAcoustic Fan
F – MCHX, E-Coat, AeroAcoustic Fan
J – MCHX, AeroAcoustic Fan, Compressor Blanket(s)
K – MCHX, E-Coat, AeroAcoustic Fan, Compressor Blanket(s)
L – Aluminum/Copper, AeroAcoustic Fan, Compressor Blanket(s)
M – Copper/Copper, AeroAcoustic Fan, Compressor Blanket(s)
N – Aluminum/Copper, Pre-Coat, AeroAcoustic Fan, Compressor Blanket(s)
P – Aluminum/Copper, E-Coat, AeroAcoustic Fan, Compressor Blanket(s)
Q – Copper/Copper, E-Coat, AeroAcoustic Fan, Compressor Blanket(s)

Revision Level

B – Current Revision Level

Hydronic System

0 – No Pump
2 – Single Pump, 5 Hp
3 – Single Pump, 7.5 Hp
4 – Single Pump, 10 Hp
5 – Single Pump, 15 Hp
8 – Dual Pump, 7.5 Hp
9 – Dual Pump, 10 Hp
B – Dual Pump, 15 Hp
D – Single Pump, 5 Hp with VFD
F – Single Pump, 7.5 Hp with VFD
G – Single Pump, 10 Hp with VFD
H – Single Pump, 15 Hp with VFD
L – Dual Pump, 7.5 Hp with VFD
M – Dual Pump, 10 Hp with VFD
N – Dual Pump, 15 Hp with VFD

Packaging/Security Options

0 – Std Packaging
4 – Security Grilles/Hail Guards Only
8 – Skid Only
D – Skid, Security Grilles/Hail Guards
J – Skid, Top Crate, Bag
N – Skid, Top Crate, Bag, Security Grilles/Hail Guards

Controls/Communications Options

0 – Std
1 – Std, BACnet Communication
5 – EMM
6 – EMM, BACnet Communication
B – EMM, GFI
C – EMM, GFI, BACnet Communication
H – GFI
J – GFI, BACnet Communication

Electrical Options

0 – Single Point, No Disconnect, No Cooler Heater
1 – Single Point, No Disconnect, Cooler Heater
2 – Single Point, Non-Fused Disconnect, No Cooler Heater
3 – Single Point, Non-Fused Disconnect, Cooler Heater
4 – Dual Point, No Disconnect, No Cooler Heater
5 – Dual Point, No Disconnect, Cooler Heater

Ambient/Capacity Control/High SCCR Options

0 – Std Comp
1 – Hot Gas Bypass
2 – Digital Comp
3 – Std Comp, High SCCR
4 – Hot Gas Bypass, High SCCR
5 – Digital Comp, High SCCR
6 – Low Ambient, Std Comp
7 – Low Ambient, Hot Gas Bypass
8 – Low Ambient, Digital Comp
9 – Low Ambient, Std Comp, High SCCR
B – Low Ambient, Hot Gas Bypass, High SCCR
C – Low Ambient, Digital Comp, High SCCR
D – Std Comp, Suction Service Valve
F – Hot Gas Bypass, Suction Service Valve
G – Digital Comp, Suction Service Valve
H – Std Comp, High SCCR, Suction Service Valve
J – Hot Gas Bypass, High SCCR, Suction Service Valve
K – Digital Comp, High SCCR, Suction Service Valve
L – Low Ambient, Std Comp, Suction Service Valves
M – Low Ambient, Hot Gas Bypass, Suction Service Valves
N – Low Ambient, Digital Comp, Suction Service Valves
P – Low Ambient, Std Comp, High SCCR, Suction Service Valves
Q – Low Ambient, Hot Gas Bypass, High SCCR, Suction Service Valves
R – Low Ambient, Digital Comp, High SCCR, Suction Service Valves

LEGEND

EMM — Energy Management Module
GFI — Ground Fault Interrupting
MCHX — Microchannel Heat Exchanger
SCCR — Short Circuit Current Rating
VFD — Variable Frequency Drive

Fig. 5 — AquaSnap® Chiller Model Number Designation, 30RAP070-150

Table 1 — Unit Operating Weights
MCHX COIL, NO PUMP UNITS

30RAP SIZE	WEIGHT AT MOUNTING POINTS (lb)						
	A	B	C	D	E	F	Total Weight
011	243	187	144	187	—	—	762
016	261	195	147	197	—	—	800
018	363	264	209	288	—	—	1125
020	365	266	211	290	—	—	1133
025	393	290	237	321	—	—	1242
030	405	301	246	331	—	—	1283
035	652	730	413	369	—	—	2163
040	704	697	390	394	—	—	2185
045	675	758	425	379	—	—	2238
050	732	724	401	405	—	—	2263
055	744	762	437	427	—	—	2369
060	746	762	438	429	—	—	2375
070	930	984	727	770	—	—	3410
080	936	1038	791	877	—	—	3641
090	952	1057	800	888	—	—	3697
100	779	805	963	617	595	931	4690
115	796	824	1027	697	672	991	5008
130	1100	1179	1430	680	682	1380	6451
150	1120	1205	1554	779	781	1499	6938

30RAP SIZE	WEIGHT AT MOUNTING POINTS (kg)						
	A	B	C	D	E	F	Total Weight
011	110	85	66	85	—	—	346
016	119	88	67	89	—	—	363
018	165	120	95	131	—	—	510
020	166	121	96	132	—	—	514
025	178	132	108	146	—	—	564
030	184	136	112	150	—	—	582
035	296	331	187	167	—	—	981
040	319	316	177	179	—	—	991
045	306	344	193	172	—	—	1015
050	332	328	182	184	—	—	1026
055	337	346	198	193	—	—	1075
060	338	346	199	194	—	—	1077
070	422	446	330	349	—	—	1547
080	425	471	359	398	—	—	1652
090	432	479	363	403	—	—	1677
100	353	365	437	280	270	422	2127
115	361	374	466	316	305	450	2272
130	499	535	649	309	309	626	2926
150	508	546	705	353	354	680	3147

MCHX COIL, SINGLE PUMP UNITS

30RAP SIZE	WEIGHT AT MOUNTING POINTS (lb)						
	A	B	C	D	E	F	Total Weight
011	264	249	200	212	—	—	925
016	282	257	202	222	—	—	963
018	393	317	258	320	—	—	1288
020	395	319	260	322	—	—	1296
025	423	343	286	353	—	—	1405
030	436	352	294	364	—	—	1446
035	692	863	529	424	—	—	2507
040	743	832	504	450	—	—	2529
045	715	891	541	434	—	—	2582
050	771	858	515	462	—	—	2606
055	783	895	552	483	—	—	2713
060	785	896	553	485	—	—	2719
070	1036	1032	871	874	—	—	3812
080	1054	1070	963	948	—	—	4035
090	1063	1082	967	950	—	—	4061
100	1105	871	886	823	554	850	5089
115	1121	892	948	904	631	912	5407
130	1418	1252	1415	817	615	1333	6850
150	1437	1280	1537	916	714	1453	7337

30RAP SIZE	WEIGHT AT MOUNTING POINTS (kg)						
	A	B	C	D	E	F	Total Weight
011	120	113	91	96	—	—	419
016	128	117	92	101	—	—	437
018	178	144	117	145	—	—	584
020	179	145	118	146	—	—	588
025	192	155	130	160	—	—	637
030	198	160	133	165	—	—	656
035	314	391	240	192	—	—	1137
040	337	377	229	204	—	—	1147
045	324	404	245	197	—	—	1171
050	350	389	234	210	—	—	1182
055	355	406	250	219	—	—	1231
060	356	406	251	220	—	—	1233
070	470	468	395	396	—	—	1729
080	478	485	437	430	—	—	1830
090	482	491	438	431	—	—	1842
100	501	395	402	373	252	385	2308
115	508	405	430	410	286	414	2453
130	643	568	642	370	279	605	3107
150	652	581	697	415	324	659	3328

MCHX COIL, DUAL PUMP UNITS

30RAP SIZE	WEIGHT AT MOUNTING POINTS (lb)						
	A	B	C	D	E	F	Total Weight
011	285	312	256	234	—	—	1087
016	303	320	257	244	—	—	1125
018	422	370	307	350	—	—	1450
020	424	372	309	352	—	—	1458
025	452	396	336	383	—	—	1567
030	465	405	344	394	—	—	1608
035	734	993	646	477	—	—	2850
040	783	964	621	505	—	—	2872
045	757	1022	659	488	—	—	2925
050	811	991	631	517	—	—	2950
055	824	1027	669	537	—	—	3056
060	826	1027	670	539	—	—	3062
070	1123	1036	928	1005	—	—	4092
080	1159	1094	1038	1099	—	—	4390
090	1167	1104	1041	1099	—	—	4411
100	1353	908	820	990	506	797	5374
115	1367	931	881	1070	583	860	5692
130	1658	1297	1404	922	559	1295	7135
150	1676	1326	1526	1020	659	1415	7622

30RAP SIZE	WEIGHT AT MOUNTING POINTS (kg)						
	A	B	C	D	E	F	Total Weight
011	129	142	116	106	—	—	493
016	138	145	117	111	—	—	510
018	191	168	139	159	—	—	658
020	192	169	140	160	—	—	661
025	205	180	152	174	—	—	711
030	211	184	156	179	—	—	729
035	333	451	293	216	—	—	1293
040	355	437	282	229	—	—	1303
045	343	464	299	221	—	—	1327
050	368	449	286	234	—	—	1338
055	374	466	303	243	—	—	1386
060	375	466	304	244	—	—	1389
070	509	470	421	456	—	—	1856
080	526	496	471	499	—	—	1991
090	529	501	472	499	—	—	2001
100	614	412	372	449	229	361	2438
115	620	422	400	485	264	360	2582
130	752	588	637	418	254	587	3236
150	760	601	692	463	299	642	3457

NOTES:

1. See Fig. 6 for unit mounting points.

2. 30RAP chillers with Greenspeed® intelligence are not available on unit sizes 070-150.

**Table 2 — Unit Operating Weights (Al/Cu Coil)
AL/CU COIL, NO PUMP UNITS**

30RAP SIZE	POUNDS						
	A	B	C	D	E	F	Total Weight
011	244	192	170	216	—	—	822
016	263	200	171	226	—	—	860
018	367	267	237	326	—	—	1197
020	369	269	239	328	—	—	1205
025	397	293	273	369	—	—	1332
030	409	303	281	379	—	—	1372
035	695	779	440	393	—	—	2308
040	751	744	416	420	—	—	2330
045	729	819	459	409	—	—	2417
050	790	781	433	437	—	—	2441
055	800	819	470	459	—	—	2548
060	802	820	471	461	—	—	2554
070	1017	1030	862	851	—	—	3759
080	1062	1100	968	935	—	—	4064
090	1035	1153	1018	914	—	—	4119
100	887	911	1179	724	702	1145	5548
115	913	940	1261	813	789	1223	5939
130	1183	1261	1596	763	765	1545	7113
150	1213	1296	1739	871	873	1682	7673

30RAP SIZE	KILOGRAMS						
	A	B	C	D	E	F	Total Weight
011	111	87	77	98	—	—	373
016	119	91	78	102	—	—	390
018	166	121	108	148	—	—	543
020	167	122	108	149	—	—	547
025	180	133	124	167	—	—	604
030	185	138	128	172	—	—	623
035	315	353	200	178	—	—	1047
040	340	337	189	190	—	—	1057
045	331	371	208	186	—	—	1096
050	358	354	196	198	—	—	1107
055	363	372	213	208	—	—	1156
060	364	372	214	209	—	—	1158
070	461	467	391	386	—	—	1705
080	482	499	439	424	—	—	1843
090	469	523	462	414	—	—	1868
100	402	413	535	328	319	519	2517
115	414	427	572	369	358	555	2694
130	537	572	724	346	347	701	3226
150	550	588	789	395	396	763	3480

AL/CU COIL, SINGLE PUMP UNITS

30RAP SIZE	POUNDS						
	A	B	C	D	E	F	Total Weight
011	265	254	228	238	—	—	984
016	283	262	230	248	—	—	1022
018	396	320	288	356	—	—	1360
020	398	322	289	358	—	—	1368
025	427	346	323	399	—	—	1494
030	439	355	331	410	—	—	1535
035	732	912	559	448	—	—	2652
040	785	879	533	476	—	—	2674
045	765	953	579	464	—	—	2760
050	824	917	550	494	—	—	2785
055	835	954	588	514	—	—	2892
060	837	955	589	517	—	—	2898
070	1126	1140	954	942	—	—	4161
080	1164	1206	1062	1025	—	—	4457
090	1126	1255	1108	994	—	—	4483
100	1215	982	1098	929	664	1059	5947
115	1240	1012	1178	1019	750	1140	6338
130	1506	1337	1577	901	696	1495	7512
150	1534	1373	1718	1009	804	1634	8072

30RAP SIZE	KILOGRAMS						
	A	B	C	D	E	F	Total Weight
011	120	115	104	108	—	—	447
016	128	119	104	113	—	—	464
018	180	145	130	162	—	—	617
020	181	146	131	163	—	—	620
025	194	157	147	181	—	—	678
030	199	161	150	186	—	—	696
035	332	414	254	203	—	—	1203
040	356	399	242	216	—	—	1213
045	347	432	262	211	—	—	1252
050	374	416	250	224	—	—	1263
055	379	433	267	233	—	—	1312
060	380	433	267	234	—	—	1314
070	511	517	433	427	—	—	1887
080	528	547	482	465	—	—	2022
090	511	569	502	451	—	—	2033
100	551	445	498	421	301	480	2697
115	562	459	534	462	340	517	2875
130	683	606	715	409	316	678	3407
150	696	623	779	458	365	741	3661

AL/CU COIL, DUAL PUMP UNITS

30RAP SIZE	POUNDS						
	A	B	C	D	E	F	Total Weight
011	286	315	287	260	—	—	1147
016	304	323	288	270	—	—	1185
018	425	373	339	386	—	—	1522
020	427	375	340	388	—	—	1530
025	456	399	374	428	—	—	1657
030	468	408	382	439	—	—	1697
035	771	1048	678	499	—	—	2995
040	823	1015	651	528	—	—	3017
045	803	1085	699	517	—	—	3104
050	860	1051	670	548	—	—	3129
055	872	1087	708	568	—	—	3235
060	875	1087	709	570	—	—	3241
070	1201	1216	1018	1005	—	—	4441
080	1237	1282	1128	1089	—	—	4737
090	1197	1333	1177	1057	—	—	4763
100	1459	1023	1034	109	622	1004	6232
115	1483	1055	1113	1180	708	1085	6623
130	1744	1383	1565	1005	641	1458	7797
150	1771	1421	1706	1112	750	1597	8357

30RAP SIZE	KILOGRAMS						
	A	B	C	D	E	F	Total Weight
011	130	143	130	118	—	—	520
016	138	147	130	123	—	—	537
018	193	169	154	175	—	—	691
020	194	170	154	176	—	—	694
025	207	181	170	194	—	—	751
030	212	185	173	199	—	—	770
035	350	475	307	226	—	—	1358
040	373	461	295	239	—	—	1368
045	364	492	317	235	—	—	1408
050	390	477	304	249	—	—	1419
055	396	493	321	258	—	—	1467
060	397	493	322	259	—	—	1470
070	545	552	462	456	—	—	2014
080	561	581	512	494	—	—	2149
090	543	605	534	479	—	—	2160
100	662	464	469	495	282	455	2827
115	673	478	505	535	321	492	3004
130	791	627	710	456	291	661	3536
150	803	645	774	504	340	724	3790

LEGEND

AL/CU — Aluminum Fin/Copper Tube

NOTES:

1. See Fig. 6 for unit mounting points.

2. 30RAP chillers with Greenspeed® intelligence are not available on unit sizes 070-150.

Table 3 — Unit Operating Weights (Cu/Cu Coil)

CU/CU COIL, NO PUMP UNITS

30RAP SIZE	POUNDS							Total Weight	30RAP SIZE	KILOGRAMS							Total Weight
	A	B	C	D	E	F	A			B	C	D	E	F			
011	242	195	208	258	—	—	903	011	110	88	94	117	—	—	410		
016	261	203	209	268	—	—	941	016	118	92	95	122	—	—	427		
018	367	267	296	407	—	—	1337	018	167	121	134	185	—	—	607		
020	369	269	298	409	—	—	1345	020	167	122	135	186	—	—	610		
025	395	292	349	472	—	—	1508	025	179	132	158	214	—	—	684		
030	407	302	358	482	—	—	1548	030	185	137	162	219	—	—	702		
035	780	873	494	441	—	—	2588	035	354	396	224	200	—	—	1174		
040	841	833	466	470	—	—	2610	040	381	378	211	213	—	—	1184		
045	836	938	526	469	—	—	2769	045	379	426	239	213	—	—	1256		
050	904	894	495	501	—	—	2793	050	410	405	224	227	—	—	1267		
055	910	932	535	522	—	—	2900	055	413	423	243	237	—	—	1315		
060	913	933	536	525	—	—	2906	060	414	423	243	238	—	—	1318		
070	1179	1194	999	987	—	—	4359	070	535	542	453	448	—	—	1977		
080	1250	1294	1140	1100	—	—	4784	080	567	587	517	499	—	—	2170		
090	1216	1354	1196	1073	—	—	4839	090	552	614	542	487	—	—	2195		
100	992	1016	1389	829	808	1354	6388	100	450	461	630	376	366	614	2898		
115	1033	1060	1501	933	909	1463	6899	115	469	481	681	423	412	664	3129		
130	1319	1395	1867	898	900	1814	8193	130	598	633	847	407	408	823	3716		
150	1363	1445	2039	1021	1023	1981	8873	150	618	655	925	463	464	899	4025		

CU/CU COIL, SINGLE PUMP UNITS

30RAP SIZE	POUNDS							Total Weight	30RAP SIZE	KILOGRAMS							Total Weight
	A	B	C	D	E	F	A			B	C	D	E	F			
011	262	257	270	276	—	—	1065	011	119	117	123	125	—	—	483		
016	281	265	271	286	—	—	1103	016	127	120	123	130	—	—	501		
018	397	320	350	433	—	—	1500	018	180	145	159	196	—	—	680		
020	399	322	351	435	—	—	1508	020	181	146	159	197	—	—	684		
025	426	345	403	497	—	—	1670	025	193	156	183	225	—	—	758		
030	438	354	410	508	—	—	1711	030	199	161	186	230	—	—	776		
035	809	1009	618	496	—	—	2932	035	367	458	280	225	—	—	1330		
040	867	971	589	526	—	—	2954	040	393	441	267	239	—	—	1340		
045	862	1074	652	523	—	—	3112	045	391	487	296	237	—	—	1412		
050	928	1033	620	556	—	—	3137	050	421	469	281	252	—	—	1423		
055	936	1071	660	577	—	—	3244	055	425	486	299	262	—	—	1471		
060	939	1071	661	579	—	—	3250	060	426	486	300	263	—	—	1474		
070	1288	1304	1091	1078	—	—	4761	070	584	591	495	489	—	—	2160		
080	1352	1401	1233	1191	—	—	5177	080	613	635	559	540	—	—	2348		
090	1307	1456	1285	1154	—	—	5203	090	593	660	583	524	—	—	2360		
100	1317	1090	1308	1030	773	1268	6787	100	597	494	593	467	351	575	3078		
115	1357	1135	1418	1135	873	1379	7298	115	615	515	643	515	396	626	3310		
130	1639	1474	1846	1035	832	1766	8592	130	743	668	837	469	377	801	3897		
150	1682	1525	2017	1158	955	1935	9272	150	763	692	915	525	433	878	4206		

CU/CU COIL, DUAL PUMP UNITS

30RAP SIZE	POUNDS							Total Weight	30RAP SIZE	KILOGRAMS							Total Weight
	A	B	C	D	E	F	A			B	C	D	E	F			
011	306	337	307	278	—	—	1228	011	139	153	139	126	—	—	557		
016	324	345	307	289	—	—	1266	016	147	157	139	131	—	—	574		
018	464	407	370	421	—	—	1662	018	210	185	168	191	—	—	754		
020	466	409	372	423	—	—	1670	020	211	186	169	192	—	—	758		
025	504	441	414	473	—	—	1833	025	229	200	188	215	—	—	831		
030	517	450	422	484	—	—	1873	030	234	204	191	220	—	—	850		
035	843	1146	741	545	—	—	3275	035	382	520	336	247	—	—	1485		
040	900	1110	711	576	—	—	3297	040	408	503	323	261	—	—	1495		
045	894	1208	778	576	—	—	3456	045	406	548	353	261	—	—	1568		
050	957	1169	745	610	—	—	3481	050	434	530	338	277	—	—	1579		
055	967	1205	785	630	—	—	3587	055	439	547	356	286	—	—	1627		
060	970	1206	786	632	—	—	3593	060	440	547	356	287	—	—	1630		
070	1364	1381	1156	1141	—	—	5041	070	618	626	524	518	—	—	2287		
080	1425	1476	1300	1255	—	—	5457	080	647	670	590	569	—	—	2475		
090	1378	1534	1355	1216	—	—	5483	090	625	696	614	552	—	—	2487		
100	1558	1134	1246	1187	735	1211	7072	100	707	514	565	539	333	549	3208		
115	1597	1181	1356	1291	836	1323	7583	115	724	536	615	586	379	600	3440		
130	1875	1523	1834	1137	778	1730	8877	130	851	691	832	516	353	785	4026		
150	1917	1575	2004	1260	902	1899	9557	150	870	715	909	571	406	861	4335		

LEGEND

CU/CU — Copper Fin/Copper Tube

NOTES:

1. See Fig. 6 for unit mounting points.
2. 30RAP chillers with Greenspeed® intelligence are not available on unit sizes 070-150.

Table 4 — Unit Operating Weights (RTPF AL/CU COIL)

RTPF AL/CU COIL, NO PUMP UNITS

30RAP SIZE	WEIGHT AT MOUNTING POINTS (POUNDS)						
	A	B	C	D	E	F	Total Weight
070	1017	1030	862	851	—	—	3759
080	1062	1100	968	935	—	—	4064
090	1035	1153	1018	914	—	—	4119
100	887	911	1179	724	702	1145	5548
115	913	940	1261	813	789	1223	5939
130	1183	1261	1596	763	765	1545	7113
150	1213	1296	1739	871	873	1682	7673

30RAP SIZE	WEIGHT AT MOUNTING POINTS (KILOGRAMS)						
	A	B	C	D	E	F	Total Weight
070	461	467	391	386	—	—	1705
080	482	499	439	424	—	—	1843
090	469	523	462	414	—	—	1868
100	402	413	535	328	319	519	2517
115	414	427	572	369	358	555	2694
130	537	572	724	346	347	701	3226
150	550	588	789	395	396	763	3480

RTPF AL/CU COIL, SINGLE PUMP UNITS

30RAP SIZE	POUNDS						
	A	B	C	D	E	F	Total Weight
070	1126	1140	954	942	—	—	4161
080	1164	1206	1062	1025	—	—	4457
090	1126	1255	1108	994	—	—	4483
100	1215	982	1098	929	664	1059	5947
115	1240	1012	1178	1019	750	1140	6338
130	1506	1337	1577	901	696	1495	7512
150	1534	1373	1718	1009	804	1634	8072

30RAP SIZE	KILOGRAMS						
	A	B	C	D	E	F	Total Weight
070	511	517	433	427	—	—	1887
080	528	547	482	465	—	—	2022
090	511	569	502	451	—	—	2033
100	551	445	498	421	301	480	2697
115	562	459	534	462	340	517	2875
130	683	606	715	409	316	678	3407
150	696	623	779	458	365	741	3661

RTPF AL/CU COIL, DUAL PUMP UNITS

30RAP SIZE	POUNDS						
	A	B	C	D	E	F	Total Weight
070	1201	1216	1018	1005	—	—	4441
080	1237	1282	1128	1089	—	—	4737
090	1197	1333	1177	1057	—	—	4763
100	1459	1023	1034	109	622	1004	6232
115	1483	1055	1113	1180	708	1085	6623
130	1744	1383	1565	1005	641	1458	7797
150	1771	1421	1706	1112	750	1597	8357

30RAP SIZE	KILOGRAMS						
	A	B	C	D	E	F	Total Weight
070	545	552	462	456	—	—	2014
080	561	581	512	494	—	—	2149
090	543	605	534	479	—	—	2160
100	662	464	469	495	282	455	2827
115	673	478	505	535	321	492	3004
130	791	627	710	456	291	661	3536
150	803	645	774	504	340	724	3790

LEGEND

CU/CU — Copper Fin/Copper Tube

NOTES:

1. See Fig. 6 for unit mounting points.
2. 30RAP chillers with Greenspeed® intelligence are not available on unit sizes 070-150.

Table 5 — Unit Operating Weights (RTPF CU/CU COIL)

RTPF CU/CU COIL, NO PUMP UNITS

30RAP SIZE	WEIGHT AT MOUNTING POINTS (POUNDS)						
	A	B	C	D	E	F	Total Weight
070	1179	1194	999	987	—	—	4359
080	1250	1294	1140	1100	—	—	4784
090	1216	1354	1196	1073	—	—	4839
100	992	1016	1389	829	808	1354	6388
115	1033	1060	1501	933	909	1463	6899
130	1319	1395	1867	898	900	1814	8193
150	1363	1445	2039	1021	1023	1981	8873

30RAP SIZE	WEIGHT AT MOUNTING POINTS (KILOGRAMS)						
	A	B	C	D	E	F	Total Weight
070	535	542	453	448	—	—	1977
080	567	587	517	499	—	—	2170
090	552	614	542	487	—	—	2195
100	450	461	630	376	366	614	2898
115	469	481	681	423	412	664	3129
130	598	633	847	407	408	823	3716
150	618	655	925	463	464	899	4025

RTPF CU/CU COIL, SINGLE PUMP UNITS

30RAP SIZE	POUNDS						
	A	B	C	D	E	F	Total Weight
070	1288	1304	1091	1078	—	—	4761
080	1352	1401	1233	1191	—	—	5177
090	1307	1456	1285	1154	—	—	5203
100	1317	1090	1308	1030	773	1268	6787
115	1357	1135	1418	1135	873	1379	7298
130	1639	1474	1846	1035	832	1766	8592
150	1682	1525	2017	1158	955	1935	9272

30RAP SIZE	KILOGRAMS						
	A	B	C	D	E	F	Total Weight
070	584	591	495	489	—	—	2160
080	613	635	559	540	—	—	2348
090	593	660	583	524	—	—	2360
100	597	494	593	467	351	575	3078
115	615	515	643	515	396	626	3310
130	743	668	837	469	377	801	3897
150	763	692	915	525	433	878	4206

RTPF CU/CU COIL, DUAL PUMP UNITS

30RAP SIZE	POUNDS						
	A	B	C	D	E	F	Total Weight
070	1364	1381	1156	1141	—	—	5041
080	1425	1476	1300	1255	—	—	5457
090	1378	1534	1355	1216	—	—	5483
100	1558	1134	1246	1187	735	1211	7072
115	1597	1181	1356	1291	836	1323	7583
130	1875	1523	1834	1137	778	1730	8877
150	1917	1575	2004	1260	902	1899	9557

30RAP SIZE	KILOGRAMS						
	A	B	C	D	E	F	Total Weight
070	618	626	524	518	—	—	2287
080	647	670	590	569	—	—	2475
090	625	696	614	552	—	—	2487
100	707	514	565	539	333	549	3208
115	724	536	615	586	379	600	3440
130	851	691	832	516	353	785	4026
150	870	715	909	571	406	861	4335

LEGEND

CU/CU — Copper Fin/Copper Tube

NOTES:

1. See Fig. 6 for unit mounting points.
2. 30RAP chillers with Greenspeed® intelligence are not available on unit sizes 070-150.

30RAP011-030 UNITS

CONTROL BOX SIDE

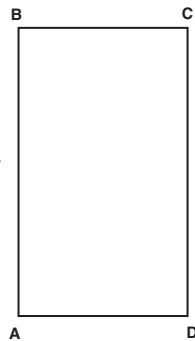

30RAP035-090 UNITS

CONTROL BOX SIDE

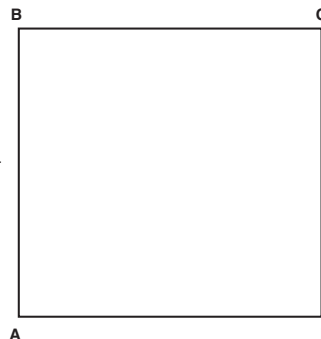

30RAP100-150 UNITS

CONTROL BOX SIDE

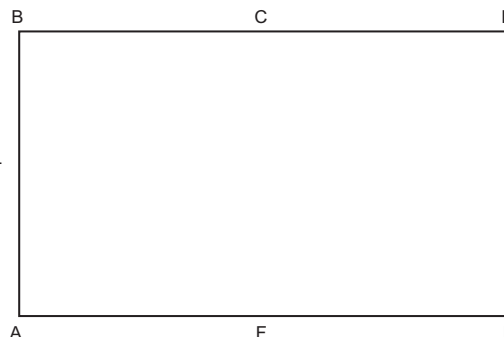

Fig. 6 — Unit Mounting Points

Table 6 — Physical Data, 30RAP — English

UNIT 30RAP	011	016	018	020	025
OPERATING WEIGHT (lb)					
MCHX Condenser Coil, No Pump	762	800	1125	1133	1242
MCHX Condenser Coil, Single Pump (60 Hz only)	925	963	1288	1296	1405
MCHX Condenser Coil, Dual Pump (60 Hz only)	1087	1125	1450	1458	1567
Al-Cu Condenser Coil, No Pump	822	860	1197	1205	1332
Al-Cu Condenser Coil, Single Pump (60 Hz only)	985	1023	1360	1368	1495
Al-Cu Condenser Coil, Dual Pump (60 Hz only)	1147	1185	1522	1530	1657
Cu-Cu Condenser Coil, No Pump	903	941	1337	1345	1508
Cu-Cu Condenser Coil, Single Pump (60 Hz only)	1066	1104	1500	1508	1671
Cu-Cu Condenser Coil, Dual Pump (60 Hz only)	1228	1266	1662	1670	1833
REFRIGERANT TYPE					
	R-410A, EXV Controlled System				
Total Refrigerant Charge MCHX (lb)	8.3	9.3	14.6	15.2	16.7
Refrigerant Charge MCHX (lb) Ckt A/Ckt B	8.3/—	9.3/—	14.6/—	15.2/—	16.7/—
Total Refrigerant Charge RTPF (lb)	20.3	21.3	31.0	31.6	36.9
Refrigerant Charge RTPF (lb) Ckt A/Ckt B	20.3/—	21.3/—	31.0/—	31.6/—	36.9/—
COMPRESSORS					
	Scroll, Hermetic				
Quantity	2	2	2	2	2
Speed (Rpm)	3500 (60 Hz)/2900 (50 Hz)				
(Qty) Tons, Ckt A	(2) 6/4	(2) 9/6	(2) 9	(2) 10	(2) 13
(Qty) Tons, Ckt B	—	—	—	—	—
Oil Charge (Pt) Ckt A/Ckt B	6.4/—	9.1/—	13.8/—	13.8/—	13.8/—
No. Capacity Steps					
Standard	3	3	2	2	2
With Hot Gas Bypass	—	—	3	3	3
Digital Compressor Option	21	21	22	22	22
Minimum Capacity Step (%)					
Standard	40	40	50	50	50
With Hot Gas Bypass	—	—	20	24	29
Digital Compressor Option	20	20	17	17	17
Capacity (%)					
Circuit A	100	100	100	100	100
Circuit B	—	—	—	—	—
COOLER					
	Braze, Direct-Expansion Plate Heat Exchanger				
Weight (lb) (empty)	22.4	31.8	31.8	40.3	46.3
Net Fluid Volume (gal)	0.6	0.9	0.9	1.2	1.4
Maximum Refrigerant Pressure (psig)	505	505	505	505	505
Maximum Water-Side Pressure Without Pump(s) (psig)	300	300	300	300	300
Maximum Water-Side Pressure With Pump(s) (psig)	150	150	150	150	150
CHILLER WATER CONNECTIONS (in.)					
Inlet and Outlet, Victaulic (IPS Carbon Steel)*	2	2	2	2	2
Drain (NPT)	1/4	1/4	1/4	1/4	1/4
CONDENSER FANS					
	Plastic Type, Axial, Vertical Discharge				
Standard Low-Sound AeroAcoustic™ Type	850 (60 Hz)/710 (50 Hz)				
Fan Speed (Rpm)	9...30	9...30	9...30	9...30	9...30
No. Blades...Diameter (in.)	1	1	2	2	2
Total Airflow 60 Hz (Cfm)	9400	9400	17,500	17,500	19,400
Total Airflow 50 Hz (Cfm)	7849	7849	14,613	14,613	16,199
Optional Value Sound Type	Propeller Type, Axial, Vertical Discharge				
	1140 (60 Hz)/950 (50 Hz)				
Fan Speed (Rpm)	4...30	4...30	4...30	4...30	4...30
No. Blades...Diameter (in.)	1	1	2	2	2
Total Airflow 60 Hz (Cfm)	10,100	10,100	18,500	18,500	20,900
Total Airflow 50 Hz (Cfm)	8434	8434	15,448	15,448	17,452
CONDENSER COILS					
	Novation® MCHX Aluminum Tube, Aluminum Fin				
Quantity (Ckt A/Ckt B)	1/—	1/—	1/—	1/—	1/—
Total Face Area (sq ft)	19	19	26	26	33
Maximum Refrigerant Pressure (psig)	656	656	656	656	656
HYDRONIC MODULE (Optional, 60 Hz only)†					
Pump	Pump(s), Strainer with Blowdown Valve, Expansion Tank, Pressure Taps, Drain and Vent Plugs, Flow Switch, and Balance Valve				
Expansion Tank Volume (gal)	Single or Dual, Centrifugal Monocell Pump(s), 3500 Rpm. Dual pumps with check valves and isolation valves.				
Total/Acceptance	4.4/3.2				
CHASSIS DIMENSIONS (ft - in.)					
Length	5-7	5-7	7-5	7-5	7-5
Width	3-5	3-5	3-5	3-5	3-5
Height	5-6	5-6	5-6	5-6	6-6

LEGEND

EXV — Electronic Expansion Valve
MCHX — Microchannel Heat Exchanger
RTPF — Round Tube, Plate Fin (Condenser Coil)

*Unit connection is IPS Carbon Steel piping.

†Flow switch and strainer are standard on all units, with or without hydronic package.

NOTE: 30RAP chillers with Greenspeed intelligence are not available on unit sizes 070-150.

Table 6 — Physical Data, 30RAP — English (cont)

UNIT 30RAP	030	035	040	045	050	055	060	
OPERATING WEIGHT (lb)								
MCHX Condenser Coil, No Pump	1283	2163	2185	2238	2263	2369	2375	
MCHX Condenser Coil, Single Pump (60 Hz only)	1446	2507	2529	2582	2606	2713	2719	
MCHX Condenser Coil, Dual Pump (60 Hz only)	1608	2850	2872	2925	2950	3056	3062	
Al-Cu Condenser Coil, No Pump	1372	2308	2330	2417	2442	2548	2554	
Al-Cu Condenser Coil, Single Pump (60 Hz only)	1535	2652	2674	2761	2785	2892	2898	
Al-Cu Condenser Coil, Dual Pump (60 Hz only)	1697	2995	3017	3104	3129	3235	3241	
Cu-Cu Condenser Coil, No Pump	1548	2588	2610	2769	2794	2900	2906	
Cu-Cu Condenser Coil, Single Pump (60 Hz only)	1711	2932	2954	3113	3137	3244	3250	
Cu-Cu Condenser Coil, Dual Pump (60 Hz only)	1873	3275	3297	3456	3481	3587	3593	
REFRIGERANT TYPE								
Total Refrigerant Charge MCHX (lb)	19.0	31.0	R-410A, EXV Controlled System		34.6	37.0	37.0	
Refrigerant Charge MCHX (lb) Ckt A/Ckt B	19.0/—	15.5/15.5	15.6/15.8	17.3/17.3	18.2/18.4	18.5/18.5	18.5/18.5	
Total Refrigerant Charge RTPF (lb)	39.3	63.4	63.8	70.6	72.6	73.0	73.0	
Refrigerant Charge RTPF (lb) Ckt A/Ckt B	39.3/—	31.7/31.7	31.8/32.0	35.3/35.3	36.2/36.4	36.5/36.5	36.5/36.5	
COMPRESSORS								
Quantity	2	4	4	4	4	4	4	
Speed (Rpm)			3500	3500	3500	3500	3500	
(Qty) Tons, Ckt A	(2) 15	(2) 10	(2) 10	(2) 11	(2) 13	(2) 13	(2) 15	
(Qty) Tons, Ckt B	—	(2) 9	(2) 11	(2) 13	(2) 13	(2) 15	(2) 15	
Oil Charge (Pt) Ckt A/Ckt B	13.8/—	13.8/13.8	13.8/13.8	13.8/13.8	13.8/13.8	13.8/13.8	13.8/13.8	
No. Capacity Steps								
Standard	2	4	4	4	4	4	4	
With Hot Gas Bypass	3	5	5	5	5	5	5	
Digital Compressor Option	22	44	44	44	44	44	44	
Minimum Capacity Step (%)								
Standard	50	23	23	24	25	23	25	
With Hot Gas Bypass	32	9	11	12	14	13	16	
Digital Compressor Option	17	9	8	8	8	8	8	
Capacity (%)								
Circuit A	100	54	47	47	50	46	50	
Circuit B	—	46	53	53	50	54	50	
COOLER								
Weight (lb) (empty)	99.3	98	Braze, Direct-Expansion Plate Heat Exchanger					140
Net Fluid Volume (gal)	2.62	3.4	109	117	129	140	140	
Maximum Refrigerant Pressure (psig)	565	565	3.9	4.2	4.6	5.2	5.2	
Maximum Water-Side Pressure Without Pump(s) (psig)	300	300	300	300	300	300	300	
Maximum Water-Side Pressure With Pump(s) (psig)	150	150	150	150	150	150	150	
CHILLER WATER CONNECTIONS (in.)								
Inlet and Outlet, Victaulic (IPS Carbon Steel)*	2	2 1/2	2 1/2	2 1/2	2 1/2	2 1/2	2 1/2	
Drain (NPT)	1/4	1/4	1/4	1/4	1/4	1/4	1/4	
CONDENSER FANS								
Standard Low-Sound AeroAcoustic™ Type								
Fan Speed (Rpm)	Plastic Type, Axial, Vertical Discharge							
No. Blades...Diameter (in.)	850 (60 Hz)/710 (50 Hz)							
No. Fans	9...30	9...30	9...30	9...30	9...30	9...30	9...30	
Total Airflow 60 Hz (Cfm)	2	3	3	3	3	4	4	
Total Airflow 50 Hz (Cfm)	19,400	29,600	29,600	30,500	30,500	38,800	38,800	
Optional Value Sound Type	16,199	24,716	24,716	25,468	25,468	32,398	32,398	
Propeller Type, Axial, Vertical Discharge								
Fan Speed (Rpm)	1140 (60 Hz)/950 (50 Hz)							
No. Blades...Diameter (in.)	4...30	4...30	4...30	4...30	4...30	4...30	4...30	
No. Fans	2	3	3	3	3	4	4	
Total Airflow 60 Hz (Cfm)	20,900	32,000	32,000	33,300	33,300	41,800	41,800	
Total Airflow 50 Hz (Cfm)	17,452	26,720	26,720	27,805	27,805	34,903	34,903	
CONDENSER COILS								
Quantity (Ckt A/Ckt B)	1/—	1/1	Novation® MCHX Aluminum Tube, Aluminum Fin					1/1
Total Face Area (sq ft)	33	53	53	66	66	66	66	
Maximum Refrigerant Pressure (psig)	656	656	656	656	656	656	656	
HYDRONIC MODULE (Optional, 60 Hz only)†								
Pump	Pump(s), Strainer with Blowdown Valve, Expansion Tank, Pressure Taps, Drain and Vent Plugs, Flow Switch, and Balance Valve							
Expansion Tank Volume (gal)	Single or Dual, Centrifugal Monocell Pump(s), 3500 Rpm. Dual pumps with check valves and isolation valves.							
Total/Acceptance	4.4/3.2	10.3/10.3						
CHASSIS DIMENSIONS (ft - in.)								
Length	7-5	7-5	7-5	7-5	7-5	7-5	7-5	
Width	3-5	7-9	7-9	7-9	7-9	7-9	7-9	
Height	6-6	5-6	5-6	6-6	6-6	6-6	6-6	

LEGEND

EXV — Electronic Expansion Valve
MCHX — Microchannel Heat Exchanger
RTPF — Round Tube, Plate Fin (Condenser Coil)

*Unit connection is IPS Carbon Steel piping.
†Flow switch and strainer are standard on all units, with or without hydronic package.
NOTE: 30RAP chillers with Greenspeed intelligence are not available on unit sizes 070-150.

Table 6 — Physical Data, 30RAP — English (cont)

UNIT 30RAP	070	080	090	100	115	130	150
OPERATING WEIGHT (lb)							
MCHX Condenser Coil, No Pump	3410	3641	3697	4690	5008	6451	6938
MCHX Condenser Coil, Single Pump (60 Hz only)	3812	4035	4061	5089	5407	6850	7337
MCHX Condenser Coil, Dual Pump (60 Hz only)	4092	4390	4411	5374	5692	7135	7622
Al-Cu Condenser Coil, No Pump	3759	4064	4119	5548	5939	7113	7673
Al-Cu Condenser Coil, Single Pump (60 Hz only)	4161	4457	4483	5947	6338	7512	8072
Al-Cu Condenser Coil, Dual Pump (60 Hz only)	4441	4737	4763	6232	6623	7797	8357
Cu-Cu Condenser Coil, No Pump	4359	4784	4839	6388	6899	8193	8873
Cu-Cu Condenser Coil, Single Pump (60 Hz only)	4761	5177	5203	6787	7298	8592	9272
Cu-Cu Condenser Coil, Dual Pump (60 Hz only)	5041	5457	5483	7072	7583	8877	9557
REFRIGERANT TYPE							
	R-410A, EXV Controlled System						
Total Refrigerant Charge MCHX (lb)	60.5	70.2	71.0	88.3	100.9	110.4	119.5
Refrigerant Charge MCHX (lb) Ckt A/Ckt B	25.5/35	35.1/35.1	35.5/35.5	39.3/49.0	50.6/50.3	51.2/59.2	60.0/59.5
Total Refrigerant Charge RTPF (lb)	150.0	169.2	170.0	192.0	213.0	239.2	264.0
Refrigerant Charge RTPF (lb) Ckt A/Ckt B	65.5/84.5	84.6/84.6	85.0/85.0	87.0/105.0	106.5/106.5	107.5/131.7	132.0/132.0
COMPRESSORS							
	Scroll, Hermetic						
Quantity	5	6	6	5	6	6	6
Speed (Rpm)	3500 (60 Hz)/ 2900 (50Hz)						
(Qty, Tons) Ckt A	(2) 15	(3) 13	(3) 15	(1) 20 (1) 25	(3) 20	(3) 20	(3) 25
(Qty, Tons) Ckt B	(3) 15	(3) 15	(3) 15	(3) 20	(3) 20	(3) 25	(3) 25
Oil Charge (Pt) Ckt A/Ckt B	13.8/20.6	20.6/20.6	20.6/20.6	28.4/42.6	42.6/42.6	42.6/42.6	42.6/42.6
No. Capacity Steps							
Standard	5	6	6	5	6	6	6
With Hot Gas Bypass	6	7	7	6	7	7	7
Digital Compressor Option	55	66	66	—	—	—	—
Minimum Capacity Step (%)							
Standard	20	15	17	19	17	15	17
With Hot Gas Bypass	13	9	11	13	11	9	11
Digital Compressor Option	7	5	6	—	—	—	—
Capacity (%)							
Circuit A	40	46	50	43	50	44	50
Circuit B	60	54	50	57	50	56	50
COOLER							
	Brazed, Direct-Expansion Plate Heat Exchanger						
Weight (lb) (empty)	197	228	245	267	304	334	378
Net Fluid Volume (gal)	4.3	5.0	6.8	7.4	8.6	9.5	10.9
Maximum Refrigerant Pressure (psig)	450	450	450	450	450	450	450
Maximum Water-Side Pressure Without Pump(s) (psig)	300	300	300	300	300	300	300
Maximum Water-Side Pressure With Pump(s) (psig)	150	150	150	150	150	150	150
CHILLER WATER CONNECTIONS (in.)							
Inlet and Outlet, Victaulic (IPS Carbon Steel)*	3	3	3	4	4	4	4
Drain (NPT)	1/4	1/4	1/4	1/4	1/4	1/4	1/4
CONDENSER FANS							
Standard Low-Sound AeroAcoustic™ Type							
Fan Speed (Rpm)							
No. Blades...Diameter (in.)							
No. Fans							
Total Airflow, 60 Hz (Cfm)							
Total Airflow, 50 Hz (Cfm)							
Optional Value Sound Type							
Fan Speed (Rpm)							
No. Blades...Diameter (in.)							
No. Fans							
Total Airflow, 60 Hz (Cfm)							
Total Airflow, 50 Hz (Cfm)							
CONDENSER COILS							
Novation® MCHX Aluminum Tube, Aluminum Fin or RTPF							
Quantity (Ckt A/Ckt B)	2/3	3/3	3/3	3/4	4/4	4/5	5/5
Total Face Area (sq ft)	124.7	149.6	149.6	174.5	199.4	224.4	249.3
Maximum Refrigerant Pressure (psig)	656	656	656	656	656	656	656
HYDRONIC MODULE (Optional, 60 Hz Only)†							
Pump(s), Strainer with Blowdown Valve, Expansion Tank, Pressure Taps, Drain and Vent Plugs, Flow Switch, and Balance Valve							
Single or Dual, Centrifugal Monocell Pump(s), 3500 Rpm. Dual pumps with check valves and isolation valves.							
Pump	—	—	—	—	—	—	—
Expansion Tank Volume (gal)	—	—	—	—	—	—	—
Total/Acceptance	—	—	—	—	—	—	—
CHASSIS DIMENSIONS (ft - in.)							
Length	12-7	12-7	12-7	15-11	15-11	19-4	19-4
Width	7-4	7-4	7-4	7-4	7-4	7-4	7-4
Height	6-6	6-6	6-6	6-6	6-6	6-6	6-6

*Unit connection is IPS Carbon Steel piping.

†Flow switch and strainer are standard on all units, with or without hydronic package.

NOTE: 30RAP chillers with Greenspeed intelligence are not available on unit sizes 070-150.

LEGEND

- EXV — Electronic Expansion Valve
- MCHX — Microchannel Heat Exchanger
- RTPF — Round Tube, Plate Fin (Condenser Coil)

Table 7 — Physical Data, 30RAP — SI

UNIT 30RAP	011	016	018	020	025
OPERATING WEIGHT (kg)					
MCHX Condenser Coil, No Pump	346	363	510	514	564
MCHX Condenser Coil, Single Pump (60 Hz only)	419	437	584	588	637
MCHX Condenser Coil, Dual Pump (60 Hz only)	493	510	658	661	711
Al-Cu Condenser Coil, No Pump	373	390	543	547	604
Al-Cu Condenser Coil, Single Pump (60 Hz only)	447	464	617	621	678
Al-Cu Condenser Coil, Dual Pump (60 Hz only)	520	538	691	694	751
Cu-Cu Condenser Coil, No Pump	410	427	606	610	684
Cu-Cu Condenser Coil, Single Pump (60 Hz only)	484	501	680	684	758
Cu-Cu Condenser Coil, Dual Pump (60 Hz only)	557	574	754	757	831
REFRIGERANT TYPE					
	R-410A, EXV Controlled System				
Total Refrigerant Charge MCHX (kg)	3.8	4.2	6.6	7.1	7.6
Refrigerant Charge MCHX (kg) Ckt A/Ckt B	3.8/—	4.2/—	6.6/—	7.1/—	7.6/—
Total Refrigerant Charge RTPF (kg)	9.2	9.6	14.0	14.3	16.7
Refrigerant Charge RTPF (kg) Ckt A/Ckt B	9.2/--	9.6/--	14.0/--	14.3/--	16.7/--
COMPRESSORS					
	Scroll, Hermetic				
Quantity	2	2	2	2	2
Speed (R/s)	58.3 (60 Hz)/48.3 (50 Hz)				
(Qty) kW, Ckt A	(2) 21/14	(2) 31/21	(2) 32	(2) 35	(2) 46
(Qty) kW, Ckt B	—	—	—	—	—
Oil Charge (L) Ckt A/Ckt B	3/—	4.3/—	6.5/—	6.5/—	6.5/—
No. Capacity Steps					
Standard	3	3	2	2	2
With Hot Gas Bypass	—	—	3	3	3
Digital Compressor Option	21	21	22	22	22
Minimum Capacity Step (%)					
Standard	40	40	50	50	50
With Hot Gas Bypass	—	—	20	24	29
Digital Compressor Option	20	20	17	17	17
Capacity (%)					
Circuit A	100	100	100	100	100
Circuit B	—	—	—	—	—
COOLER					
	Brazed, Direct-Expansion Plate Heat Exchanger				
Weight (kg) (empty)	10.1	14.4	14.4	18.3	21.0
Net Fluid Volume (L)	2.3	3	3.4	4.5	5.3
Maximum Refrigerant Pressure (kPa)	3482	3482	3482	3482	3482
Maximum Water-Side Pressure Without Pump(s) (kPa)	2068	2068	2068	2068	2068
Maximum Water-Side Pressure With Pump(s) (kPa)	1034	1034	1034	1034	1034
CHILLER WATER CONNECTIONS (in.)					
Inlet and Outlet, Victaulic (IPS Carbon Steel)*	2	2	2	2	2
Drain (NPT)	1/4	1/4	1/4	1/4	1/4
CONDENSER FANS					
Standard Low-Sound AeroAcoustic™ Type					
Plastic Type, Axial, Vertical Discharge					
Fan Speed (R/s)	14.2 (60 Hz)/11.8 (50 Hz)				
No. Blades...Diameter (mm)	9...762	9...762	9...762	9...762	9...762
No. Fans	1	1	2	2	2
Total Airflow 60 Hz (L/s)	4437	4437	8260	8260	9157
Total Airflow 50 Hz (L/s)	3705	3705	6897	6897	7646
Optional Value Sound Type					
Propeller Type, Axial, Vertical Discharge					
Fan Speed (R/s)	19.0 (60 Hz)/15.8 (50 Hz)				
No. Blades...Diameter (mm)	4...762	4...762	4...762	4...762	4...762
No. Fans	1	1	2	2	2
Total Airflow 60 Hz (L/s)	4800	4800	8732	8732	9865
Total Airflow 50 Hz (L/s)	3981	3981	7291	7291	8237
CONDENSER COILS					
	Novation® MCHX Aluminum Tube, Aluminum Fin				
Quantity (Ckt A/Ckt B)	1/—	1/—	1/—	1/—	1/—
Total Face Area (sq m)	1.8	1.8	2.4	2.4	3.1
Maximum Refrigerant Pressure (kPa)	4523	4523	4523	4523	4523
HYDRONIC MODULE (Optional, 60 Hz Only)†					
Pump	Pump(s), Strainer with Blowdown Valve, Expansion Tank, Pressure Taps, Drain and Vent Plugs, Flow Switch, and Balance Valve				
Expansion Tank Volume (L)	Single or Dual, Centrifugal Monocell Pump(s), 3500 Rpm. Dual pumps with check valves and isolation valves.				
Total/Acceptance	17.4/12.3				
CHASSIS DIMENSIONS (mm)					
Length	1689	1689	2242	2242	2242
Width	1029	1029	1025	1025	1025
Height	1689	1689	1689	1689	1994

LEGEND

EXV — Electronic Expansion Valve
MCHX — Microchannel Heat Exchanger
RTPF — Round Tube, Plate Fin (Condenser Coil)

*Unit connection is IPS Carbon Steel piping.

†Flow switch and strainer are standard on all units, with or without hydronic package.

NOTE: 30RAP chillers with Greenspeed intelligence are not available on unit sizes 070-150.

Table 7 — Physical Data, 30RAP — SI (cont)

UNIT 30RAP	030	035	040	045	050	055	060	
OPERATING WEIGHT (kg)								
MCHX Condenser Coil, No Pump	582	981	991	1015	1026	1075	1077	
MCHX Condenser Coil, Single Pump (60 Hz only)	656	1137	1147	1171	1182	1231	1233	
MCHX Condenser Coil, Dual Pump (60 Hz only)	729	1293	1303	1327	1338	1386	1389	
Al-Cu Condenser Coil, No Pump	623	1047	1057	1096	1108	1156	1159	
Al-Cu Condenser Coil, Single Pump (60 Hz only)	696	1203	1213	1252	1263	1312	1315	
Al-Cu Condenser Coil, Dual Pump (60 Hz only)	770	1358	1368	1408	1419	1467	1470	
Cu-Cu Condenser Coil, No Pump	702	1174	1184	1256	1267	1316	1318	
Cu-Cu Condenser Coil, Single Pump (60 Hz only)	776	1330	1340	1412	1423	1472	1474	
Cu-Cu Condenser Coil, Dual Pump (60 Hz only)	850	1485	1495	1568	1579	1627	1630	
REFRIGERANT TYPE								
Total Refrigerant Charge MCHX (kg)	8.6	14.1	R-410A, EXV Controlled System		15.7	16.6	16.8	
Refrigerant Charge MCHX (kg) Ckt A/Ckt B	8.6/—	7.0/7.0	7.1/7.2	7.9/7.9	8.3/8.4	8.4/8.4	8.4/8.4	
Total Refrigerant Charge RTPF (kg)	17.8	28.8	28.9	32.0	32.9	33.1	33.1	
Refrigerant Charge RTPF (kg) Ckt A/Ckt B	17.8/--	14.4/14.4	14.4/14.5	16.0/16.0	16.4/16.5	16.6/16.6	16.6/16.6	
COMPRESSORS								
Quantity	2	4	4	Scroll, Hermetic		4	4	
Speed (R/s)				58.3	(60 Hz)/48.3 (50 Hz)			
(Qty) kW, Ckt A	(2) 53	(2) 35	(2) 35	(2) 38	(2) 46	(2) 46	(2) 53	
(Qty) kW, Ckt B	—	(2) 32	(2) 38	(2) 46	(2) 46	(2) 53	(2) 53	
Oil Charge (L) Ckt A/Ckt B	6.5/—	6.5/6.5	6.5/6.5	6.5/6.5	6.5/6.5	6.5/6.5	6.5/6.5	
No. Capacity Steps								
Standard	2	4	4	4	4	4	4	
With Hot Gas Bypass	3	5	5	5	5	5	5	
Digital Compressor Option	22	44	44	44	44	44	44	
Minimum Capacity Step (%)								
Standard	50	23	23	24	25	23	25	
With Hot Gas Bypass	32	9	11	12	14	13	16	
Digital Compressor Option	17	9	8	8	8	8	8	
Capacity (%)								
Circuit A	100	54	47	47	50	46	50	
Circuit B	—	46	53	53	50	54	50	
COOLER								
Weight (kg) (empty)	45	44.5	Brazed, Direct-Expansion Plate Heat Exchanger					63.6
Net Fluid Volume (L)	9.9	12.9	49.5	53.2	58.6	63.6	63.6	
Maximum Refrigerant Pressure (kPa)	3896	3896	3896	3896	3896	3896	3896	
Maximum Water-Side Pressure Without Pump(s) (kPa)	2068	2068	2068	2068	2068	2068	2068	
Maximum Water-Side Pressure With Pump(s) (kPa)	1034	1034	1034	1034	1034	1034	1034	
CHILLER WATER CONNECTIONS (in.)								
Inlet and Outlet, Victaulic (IPS Carbon Steel)*	2	2½	2½	2½	2½	2½	2½	
Drain (NPT)	¼	¼	¼	¼	¼	¼	¼	
CONDENSER FANS								
Standard Low-Sound AeroAcoustic™ Type			Plastic Type, Axial, Vertical Discharge					
Fan Speed (R/s)			14.2 (60 Hz)/11.8 (50 Hz)					
No. Blades...Diameter (mm)	9...762	9...762	9...762	9...762	9...762	9...762	9...762	
No. Fans	2	3	3	3	3	4	4	
Total Airflow 60 Hz (L/s)	9157	13 971	13 971	14 396	14 396	18 314	18 314	
Total Airflow 50 Hz (L/s)	7646	11 666	11 666	12 021	12 021	15 292	15 292	
Optional Value Sound Type			Propeller Type, Axial, Vertical Discharge					
Fan Speed (R/s)			19.0 (60 Hz)/15.8 (50 Hz)					
No. Blades...Diameter (mm)	4...762	4...762	4...762	4...762	4...762	4...762	4...762	
No. Fans	2	3	3	3	3	4	4	
Total Airflow 60 Hz (L/s)	9865	15 104	15 104	15 718	15 718	19 730	19 730	
Total Airflow 50 Hz (L/s)	8237	12 612	12 612	13 124	13 124	16 474	16 474	
CONDENSER COILS								
Quantity (Ckt A/Ckt B)	1/—	1/1	Novation® MCHX Aluminum Tube, Aluminum Fin		1/1	1/1	1/1	
Total Face Area (sq m)	3.1	4.9	4.9	6.1	6.1	6.1	6.1	
Maximum Refrigerant Pressure (kPa)	4523	4523	4523	4523	4523	4523	4523	
HYDRONIC MODULE (Optional, 60 Hz Only)†								
Pump	Pump(s), Strainer with Blowdown Valve, Expansion Tank, Pressure Taps, Drain and Vent Plugs, Flow Switch, and Balance Valve							
Expansion Tank Volume (L)	Single or Dual, Centrifugal Monocell Pump(s), 3500 Rpm. Dual pumps with check valves and isolation valves.							
Total/Acceptance	17.4/12.3			39.0/39.0				
CHASSIS DIMENSIONS (mm)								
Length	2242	2248	2248	2248	2248	2248	2248	
Width	1025	2350	2350	2350	2350	2350	2350	
Height	1994	1689	1689	1994	1994	1994	1994	

LEGEND

- EXV — Electronic Expansion Valve
- MCHX — Microchannel Heat Exchanger
- RTPF — Round Tube, Plate Fin (Condenser Coil)

*Unit connection is IPS Carbon Steel piping.

†Flow switch and strainer are standard on all units, with or without hydronic package.

NOTE: 30RAP chillers with Greenspeed intelligence are not available on unit sizes 070-150.

Table 7 — Physical Data, 30RAP — SI (cont)

UNIT 30RAP	070	080	090	100	115	130	150
OPERATING WEIGHT (kg)							
MCHX Condenser Coil, No Pump	1547	1652	1677	2127	2272	2926	3147
MCHX Condenser Coil, Single Pump (60 Hz only)	1729	1830	1842	2308	2453	3107	3328
MCHX Condenser Coil, Dual Pump (60 Hz only)	1856	1991	2001	2438	2582	3236	3457
AI-Cu Condenser Coil, No Pump	1705	1843	1868	2517	2694	3226	3480
AI-Cu Condenser Coil, Single Pump (60 Hz only)	1887	2022	2033	2698	2875	3407	3661
AI-Cu Condenser Coil, Dual Pump (60 Hz only)	2014	2149	2160	2827	3004	3537	3791
Cu-Cu Condenser Coil, No Pump	1977	2170	2195	2898	3129	3716	4025
Cu-Cu Condenser Coil, Single Pump (60 Hz only)	2160	2348	2360	3079	3310	3897	4206
Cu-Cu Condenser Coil, Dual Pump (60 Hz only)	2287	2475	2487	3208	3440	4027	4335
REFRIGERANT TYPE							
	R-410A, EXV Controlled System						
Total Refrigerant Charge MCHX (kg)	27.5	31.8	32.2	40.1	45.8	50.1	54.2
Refrigerant Charge MCHX (kg) Ckt A/Ckt B	11.6/15.9	15.9/15.9	16.1/16.1	17.8/22.3	23.0/22.8	23.2/26.9	27.2/27.0
Total Refrigerant Charge RTPF (kg)	68.0	76.8	77.2	87.1	96.6	108.5	119.8
Refrigerant Charge RTPF (kg) Ckt A/Ckt B	29.7/38.3	38.4/38.4	38.6/38.6	39.5/47.6	48.3/48.3	48.8/59.7	59.9/59.9
COMPRESSORS							
	Scroll, Hermetic						
Quantity	5	6	6	5	6	6	6
Speed (R/s)	58.3 (60 Hz)/48.3 (50 Hz)						
(Qty, kW) Ckt A	(2) 53	(3) 46	(3) 53	(1) 70 (1) 87.9	(3) 70	(3) 70	(3) 87.9
(Qty, kW) Ckt B	(3) 53	(3) 53	(3) 53	(3) 70	(3) 70	(3) 87.9	(3) 87.9
Oil Charge (L) Ckt A/Ckt B	6.5/9.7	9.7/9.7	9.7/9.7	13.4/20.1	20.1/20.1	20.1/20.1	20.1/20.1
No. Capacity Steps							
Standard	5	6	6	5	6	6	6
With Hot Gas Bypass	6	7	7	6	7	7	7
Digital Compressor Option	55	66	66	—	—	—	—
Minimum Capacity Step (%)							
Standard	20	15	17	19	17	15	17
With Hot Gas Bypass	13	9	11	13	11	9	11
Digital Compressor Option	7	5	6	—	—	—	—
Capacity (%)							
Circuit A	40	46	50	43	50	44	50
Circuit B	60	54	50	57	50	56	50
COOLER							
	Braze, Direct-Expansion Plate Heat Exchanger						
Weight (kg) (empty)	89.4	103.4	111.1	121.0	137.7	151.3	171.2
Net Fluid Volume (L)	16.3	18.9	25.7	28.0	32.5	35.9	41.2
Maximum Refrigerant Pressure (kPa)	3103	3103	3103	3103	3103	3103	3103
Maximum Water-Side Pressure							
Without Pump(s) (kPa)	2068	2068	2068	2068	2068	2068	2068
Maximum Water-Side Pressure							
With Pump(s) (kPa)	1034	1034	1034	1034	1034	1034	1034
CHILLER WATER CONNECTIONS (in.)							
Inlet and Outlet, Victaulic (IPS Carbon Steel)*	3	3	3	4	4	4	4
Drain (NPT)	1/4	1/4	1/4	1/4	1/4	1/4	1/4
CONDENSER FANS							
Standard Low-Sound AeroAcoustic™ Type							
Fan Speed (R/s)							
No. Blades...Diameter (mm)	9...762	9...762	9...762	9...762	9...762	9...762	9...762
No. Fans	5	6	6	7	8	9	10
Total Airflow, 60 Hz (L/s)	22 890	27 467	27 467	32 045	36 623	41 201	45 779
Total Airflow, 50 Hz (L/s)	19 120	22 943	22 943	26 767	30 591	34 415	38 239
Optional Value Sound Type							
Propeller Type, Axial, Vertical Discharge							
19.0 (60 Hz)/15.8 (50 Hz)							
Fan Speed (R/s)	4...762	4...762	4...762	4...762	4...762	4...762	4...762
No. Blades...Diameter (mm)	5	6	6	7	8	9	10
No. Fans	5	6	6	7	8	9	10
Total Airflow, 60 Hz (L/s)	24 187	29 025	29 025	33 862	38 700	43 537	48 375
Total Airflow, 50 Hz (L/s)	20 204	24 245	24 245	28 285	32 326	36 367	40 407
CONDENSER COILS							
Novation® MCHX Aluminum Tube, Aluminum Fin or RTPF							
Quantity (Ckt A/Ckt B)	2/3	3/3	3/3	3/4	4/4	4/5	5/5
Total Face Area (sq m)	11.6	13.9	13.9	16.2	18.5	20.8	23.2
Maximum Refrigerant Pressure (kPa)	4523	4523	4523	4523	4523	4523	4523
HYDRONIC MODULE (Optional, 60 Hz Only)†							
Pump(s), Strainer with Blowdown Valve, Expansion Tank, Pressure Taps, Drain and Vent Plugs, Flow Switch, and Balance Valve							
Pump	Single or Dual, Centrifugal Monocell Pump(s), 3500 Rpm. Dual pumps with check valves and isolation valves.						
Expansion Tank Volume (L)	—						
Total/Acceptance	—						
CHASSIS DIMENSIONS (mm)							
Length	3826	3826	3826	4864	4864	5893	5893
Width	2241	2241	2241	2241	2241	2241	2241
Height	1976	1976	1976	1976	1976	1976	1976

LEGEND

- EXV — Electronic Expansion Valve
- MCHX — Microchannel Heat Exchanger
- RTPF — Round Tube, Plate Fin (Condenser Coil)

*Unit connection is IPS Carbon Steel piping.

†Flow switch and strainer are standard on all units, with or without hydronic package.

NOTE: 30RAP chillers with Greenspeed intelligence are not available on unit sizes 070-150.

CAUTION - NOTICE TO RIGGERS:

ALL PANELS MUST BE IN PLACE WHEN RIGGING. FORK ONLY THROUGH BASE RAIL FORK OPENINGS.

NOTES:

1. RIG WITH FOUR CABLES USING A MINIMUM 20 FT. (6096mm) LENGTH FOR 010-030 SIZES AND 24 FT. (7315mm) LENGTH FOR 035-060 SIZES.
2. CENTRAL LIFTING POINT MUST BE A MINIMUM OF 10 FT. (3048mm) FOR 010-030 SIZES AND 12 FT. (3658mm) FOR 035-060 SIZES ABOVE THE TOP OF THE UNIT.
3. LIFTING HOLES PROVIDED ARE 2.25 IN. (57.2mm) DIAMETER.
4. CHECK BILL OF LADING FOR SHIPPING WEIGHT OF UNIT.
5. 010-030 SIZES SUBTRACT 230 LBS (104 KGS) FROM THE MAX WEIGHT FOR UNITS WITHOUT PUMPS.
035-060 SIZES SUBTRACT 290 LBS (132 KGS) FROM THE MAX WEIGHT FOR UNITS WITHOUT PUMPS.

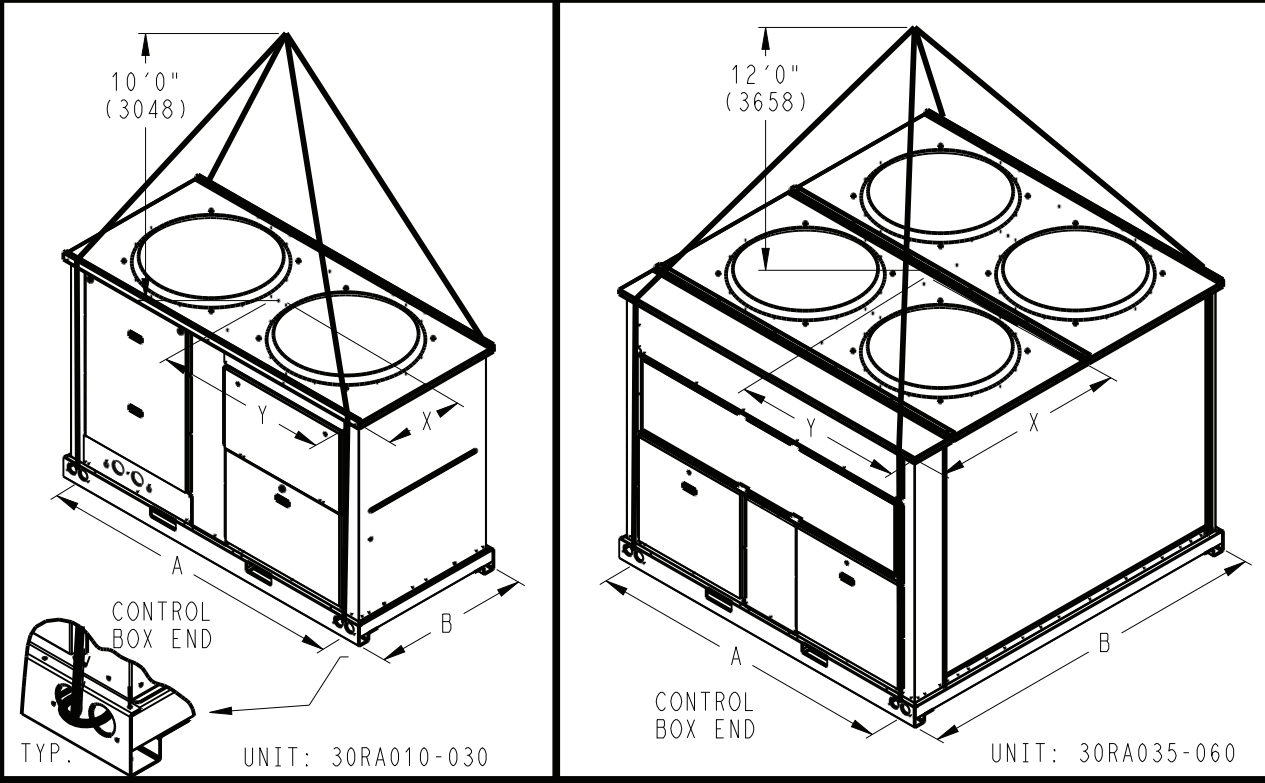

MODEL NUMBER	MCHX				RTPF(CU/CU)				LIFTING HOLES				CENTER OF GRAVITY			
	MAX. SHIP WT. W/O PACKAGING		MAX. SHIP WT. W/PACKAGING		MAX. SHIP WT. W/O PACKAGING		MAX. SHIP WT. W/PACKAGING		A		B		X		Y	
	LBS	KGS	LBS	KGS	LBS	KGS	LBS	KGS	IN	MM	IN	MM	IN	MM	IN	MM
30RA011	1087	493	1165	528	1228	557	1306	593	57.4	1458	40.3	1022	19.4	467	34.8	960
30RA016	1125	510	1203	546	1266	574	1344	609	57.4	1458	40.3	1022	19.1	466	34.3	957
30RA018	1450	658	1536	697	1662	754	1748	793	79.4	2017	40.3	1022	19.3	467	38.8	985
30RA020	1458	661	1544	700	1670	758	1756	797	79.4	2017	40.3	1022	19.3	467	38.8	985
30RA025	1567	711	1653	750	1833	831	1919	870	79.4	2017	40.3	1022	19.6	472	38.9	989
30RA030	1608	729	1694	768	1873	850	1959	889	79.4	2017	40.3	1022	19.6	472	39.0	990
30RA035	2850	1293	3055	1386	3275	1485	3480	1578	79.4	2017	92.1	2340	36.5	926	46.1	1171
30RA040	2872	1303	3077	1396	3297	1495	3502	1588	79.4	2017	92.1	2340	36.2	921	44.0	1118
30RA045	2925	1327	3130	1420	3456	1568	3661	1661	79.4	2017	92.1	2340	36.2	921	46.2	1172
30RA050	2950	1338	3155	1431	3481	1579	3686	1672	79.4	2017	92.1	2340	36.0	914	44.0	1118
30RA055	3056	1386	3261	1479	3587	1627	3792	1720	79.4	2017	92.1	2340	36.5	927	44.6	1133
30RA060	3062	1389	3267	1482	3593	1630	3798	1723	79.4	2017	92.1	2340	36.5	927	44.6	1132

38AP50000200 REV. -

Fig. 7 — Unit Rigging Label Detail (011-060 Sizes)

CAUTION - NOTICE TO RIGGERS:

ALL PANELS MUST BE IN PLACE WHEN RIGGING. DO NOT FORK THIS UNIT WITHOUT SKID.
NOTES:

1. RIG WITH FOUR CABLES USING A MINIMUM 24 FT. (7315MM) LENGTH FOR 070-115 SIZES. RIG WITH SIX CABLES FOR 130, 150 TON.
2. CENTRAL LIFTING POINTS MUST BE A MINIMUM OF 12 FT. (3658MM) ABOVE THE TOP OF THE UNIT.
3. LIFTING HOLES PROVIDED ARE 2.5 IN. (63.5MM) DIAMETER. 30RAP130 AND 30RAP150 HAVE A MIDDLE LIFTING HOLE, WHICH IS LOCATED 115.5 IN. (2921 MM) FROM THE CONTROL BOX SIDE LIFTING HOLE.
4. CHECK BILL OF LADING FOR SHIPPING WEIGHT OF UNIT.

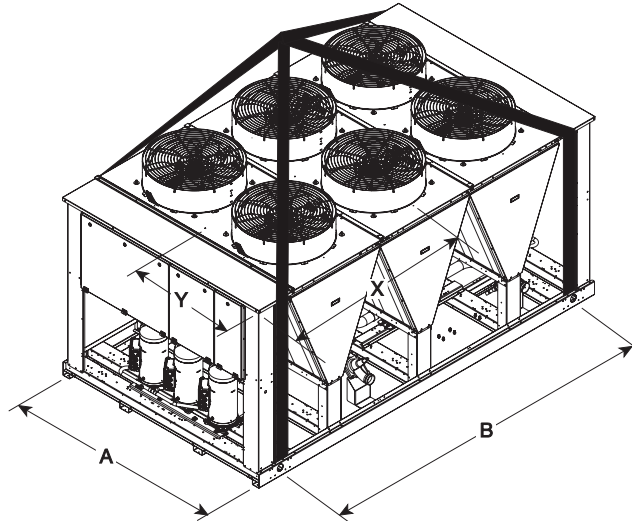

MODEL NUMBER	MAX. SHIP WT. W/O PACKAGING		MAX. SHIP WT. W/PACKAGING		MAX. SHIP WT. W/O PACKAGING		MAX. SHIP WT. W/PACKAGING		MAX. SHIP WT. W/O PACKAGING		MAX. SHIP WT. W/PACKAGING	
	LBS	KGS	LBS	KGS	LBS	KGS	LBS	KGS	LBS	KGS	LBS	KGS
	MCHX COILS				AL-CU COILS				CU-CU COILS			
30RAP070	3991	1810	4121	1869	4340	1968	4470	2027	4940	2240	5070	2299
30RAP080	4289	1945	4419	2004	4637	2103	4767	2194	5357	2429	5487	2520
30RAP090	4310	1955	4440	2014	4663	2114	4793	2205	5383	2441	5513	2532
30RAP100	5267	2389	5417	2457	6125	2778	6275	2846	6965	3159	7118	3228
30RAP115	5575	2528	5725	2596	6507	2951	6657	3019	7467	3386	7617	3454
30RAP130	7010	3179	7190	3261	7672	3479	7852	3561	8752	3969	8932	4051
30RAP150	7485	3394	7665	3476	8220	3728	8400	3809	9420	4272	9600	4354

	LIFTING HOLES				CENTER OF GRAVITY			
	A		B		X		Y	
	IN	MM	IN	MM	IN	MM	IN	MM
30RAP070	88.0	2235	131.6	3343	68.8	1748	44.4	1128
30RAP080	88.0	2235	131.6	3343	70.7	1796	44.9	1140
30RAP090	88.0	2235	131.6	3343	70.8	1798	46.5	1181
30RAP100	88.0	2235	171.8	4364	87.1	2212	45.3	1151
30RAP115	88.0	2235	171.8	4364	90.5	2299	45.2	1148
30RAP130	88.0	2235	212.1	5387	104.3	2649	45.4	1153
30RAP150	88.0	2235	212.1	5387	108.1	2746	45.3	1151

DEDUCT THESE VALUES FOR UNITS WITH NO PUMP OPTIONS		
	SINGLE PUMP DEDUCT LBS/KGS	NO PUMP DEDUCT LBS/KGS
30RAP 070,080,090	280/127	635/288
30RAP 100,115,130,150	285/129	675/306

38AP503120

Fig. 8 — Unit Rigging Label Detail (070-150 Sizes)

MOUNTING UNIT — When unit is in proper location, use of mounting holes in base rails is recommended for securing unit to supporting structure, or for mounting unit on vibration isolators if required. See Fig. 9-16. Fasteners for mounting unit are field supplied. Be sure unit is level to within $\frac{1}{8}$ in. (.32 mm) per foot for proper oil return to compressor.

Step 2 — Check Compressor Mounting — As shipped, units with single compressors are held down with 4 bolts through rubber grommets. All units with tandem compressors are held down with 6 bolts per pair through grommets. After unit is installed, verify mounting bolt torque 7 to 10 ft-lb (9.5 to 13.6 N•m).

For 30RAP100-150 units, RED bolts from compressor mounting rail must be removed. These RED bolts are for shipping purposes only. Also remove the RED shipping braces that tie the compressors in a circuit together. Using a 15-mm socket, loosen each bolt and nut on each compressor tab and remove all braces before unit start-up.

Step 3 — Connect Cooler Fluid and Drain Piping

ALL UNITS — These chillers are supplied with factory-installed strainer (including blow-down valve) in the entering fluid piping and flow switch in the leaving fluid piping. Flow switch wiring is factory installed.

CAUTION

Do not circulate water through unit without strainer in place. Failure to use the strainer represents abuse and may impair or otherwise negatively affect the Carrier product warranty.

Piping connections are located on the front of the chiller when facing the control panel for sizes 011-030 and at the end opposite the control panel for sizes 035-060. For sizes 070-150, piping connections are on the right side when facing the control panel and (Circuit B) of the chiller. See Fig. 9-16, depending on model. See Fig. 17-19 for accessory storage tank dimensions.

All sizes have carbon steel Victaulic IPS connections as shown in the physical data tables. Any connecting pipe to the 30RAP unit must be of a material that will not cause any galvanic corrosion. For this reason, dissimilar metals must not be used unless joined by a dielectric coupling.

Provide a means of venting air from the high point of the field-installed piping as required. Install field-supplied drains in both the entering and leaving fluid connections.

After field piping is complete, freeze-up protection is recommended using inhibited glycol or other suitable inhibited antifreeze solution and electric heat tapes in areas where piping is exposed to low ambient temperatures (34°F [1°C] or below). Heat tapes should possess a rating for area ambient temperatures and be covered with a suitable thickness of closed-cell insulation. Route power for heating tapes from a separately fused disconnect. Identify disconnect as heat tape power source with a warning that power must not be turned off except when unit is being serviced.

Installation of water systems should follow sound engineering practice as well as applicable local and industry standards. Improperly designed or installed systems may cause unsatisfactory operation and/or system failure. Consult a water treatment specialist or appropriate literature for information regarding filtration, water treatment, and control devices.

UNIT	CENTER OF GRAVITY		UNIT HEIGHT		WATER CONNECTION	
	X	Y	H (STANDARD)	H (VALUE SOUND)	VICTAULIC TIPS CARBON STEEL	WATER IN/OUT
30RA011	19.40 [493]	34.80 [884]	66.5 [1689]	61.0 [1549]	2"	2"
30RA016	19.10 [485]	34.30 [871]	66.5 [1689]	61.0 [1549]	2"	2"

NOTES:

- DO NOT CAP OR OTHERWISE OBSTRUCT THE LIQUID LINE TEMPERATURE RELIEF.
- Ø7/8 [22.4] PILOT HOLE PROVIDED FOR LOCATING FIELD POWER WIRING. ACTUAL HOLE REQUIRED DEPENDS ON FIELD WIRE SIZING.
- Ø0.437 [11.10] HOLE USED FOR MOUNTING UNIT.
- UNIT MUST HAVE CLEARANCES AS FOLLOWS:
TOP - DO NOT RESTRICT.
COIL SIDE - 42 [1067] FROM SOLID SURFACE.
PANEL SIDE - 46 [1219] PER NEC.
- SEE TABLE COLUMN H: DIMENSION FOR STANDARD FAN OR VALUE SOUND FAN OPTION.
- CARRIER DOES NOT RECOMMEND INSTALLATION IN A PIT.
- UNIT CAN BE HANDLED USING THE FORK TRUCK LIFT POCKETS.
- WATER CONNECTIONS RECESSED 2-3/8 INCHES INSIDE UNIT. ALL WATER DRAIN AND VENTING HOLES ARE 1/4" NPT.

DIMENSIONS IN [] ARE IN MILLIMETERS

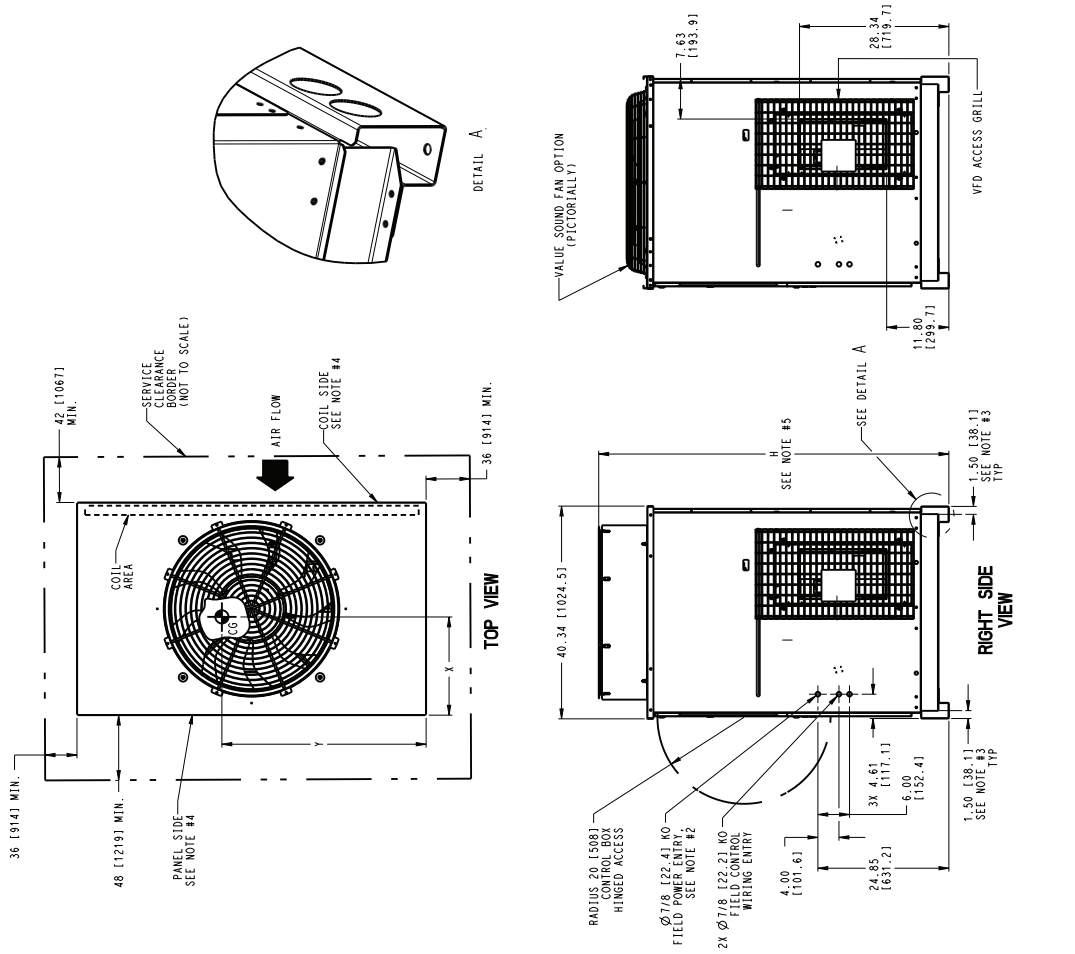

TIC CLASSIFICATION	SHEET	DATE	SUPERCEDES	DESCRIPTION	REV
U.S. - ECCN:EAR99	1 OF 1	09/07/18	A	38RAP011-016 UNIT ASSY	B
					30RA55561

Fig. 9 — Dimensions — 30RAP011 and 016 Units

UNIT	CENTER OF GRAVITY		UNIT HEIGHT	POWER ENTRY	WATER CONNECTION (CYCLIC TYP.)	
	X	Y			H (STANDARD)	H (VALUE SOUND)
30RA018	19.30 (490)	38.77 (985)	66.5 (1689)	P	24.9 (631)	2*
30RA020	19.30 (490)	38.79 (985)	66.5 (1689)	P	24.9 (631)	2*
30RA025	19.60 (498)	38.93 (989)	78.5 (1994)	P	36.9 (936)	2*
30RA030	19.60 (498)	38.98 (990)	78.5 (1994)	P	36.9 (936)	2*

NOTES:

- DO NOT CAP OR OTHERWISE OBSTRUCT THE LIQUID LINE TEMPERATURE RELIEF.
- Ø7/8 (22.4) PILOT HOLE PROVIDED FOR LOCATING FIELD POWER WIRING. ACTUAL HOLE REQUIRED DEPENDS ON FIELD WIRE SIZING.
- Ø0.437 (11.101) HOLE USED FOR MOUNTING UNIT.
- UNIT MUST HAVE CLEARANCES AS FOLLOWS:
COIL SIDE - 42 (1067) FROM SOLID SURFACE.
PANEL SIDE - 48 (1219) PER NEC.
- SEE TABLE COLUMN H; DIMENSION FOR STANDARD FAN OR VALUE SOUND FAN OPTION.
- CARRIER DOES NOT RECOMMEND INSTALLATION IN A PIT.
- UNIT CAN BE HANDLED USING THE FORK TRUCK LIFT POCKETS.
- WATER CONNECTIONS RECESSED 2 INCHES INSIDE UNIT.
ALL WATER DRAIN AND VENTING HOLES ARE 1/4" NPT.

DIMENSIONS IN () ARE IN MILLIMETERS

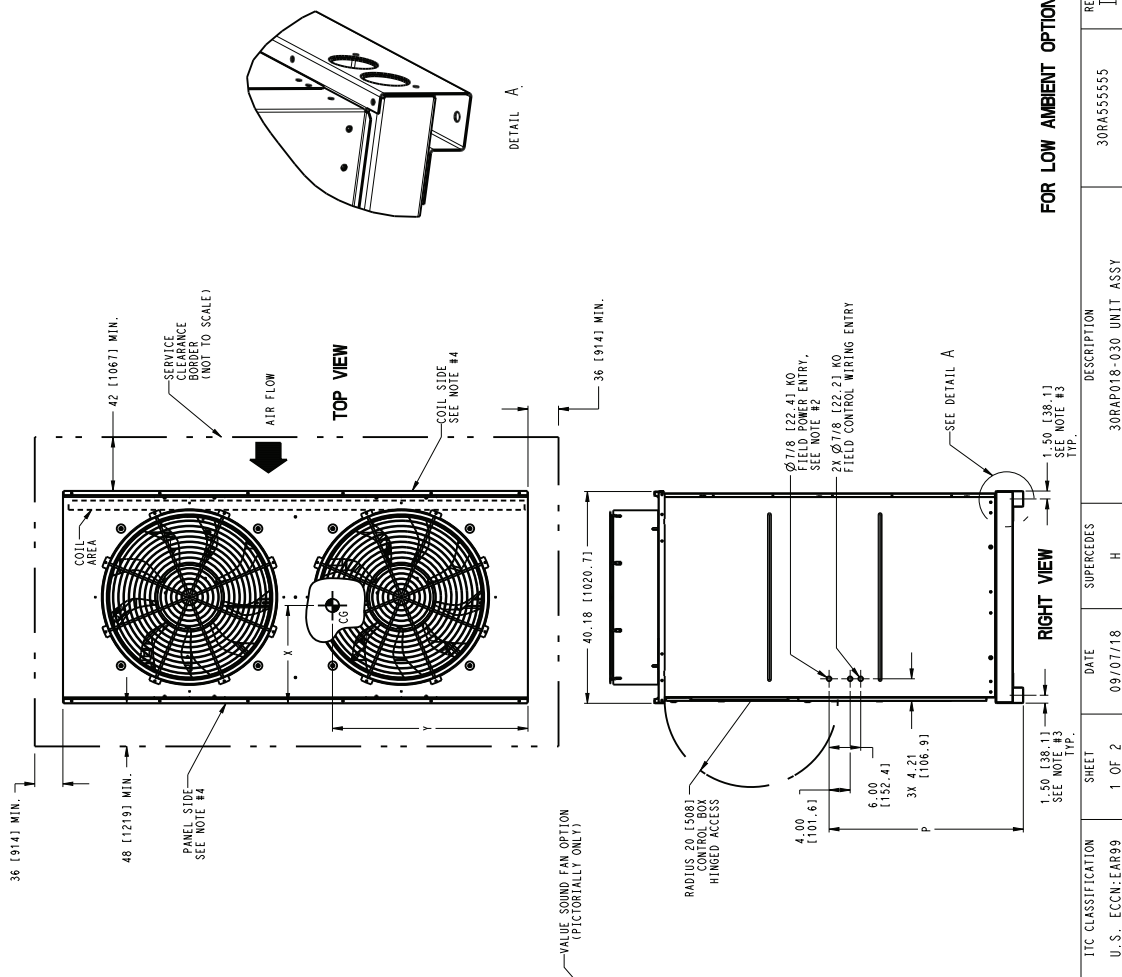

FOR LOW AMBIENT OPTION

ITC CLASSIFICATION	SHEET	DATE	SUPERCEDES	DESCRIPTION	REV
U.S. ECCN:EAR99	1 OF 2	09/07/18	H	30RAP018-030 UNIT ASSY	I

Fig. 10 — Dimensions — 30RAP018-030 Units with Fixed Speed Fans

UNIT	CENTER OF GRAVITY		UNIT HEIGHT	POWER ENTRY	WATER CONNECTION	
	X	Y			MECHANICAL IPD	CARBON STEEL
30RA018	19.30 (490)	38.77 (985)	H (STANDARD)	P	WATER IN/OUT	2"
30RA020	19.30 (490)	38.79 (985)	66.5 (1689)	24.9 (631)	WATER IN/OUT	2"
30RA025	19.60 (498)	38.93 (989)	66.5 (1689)	24.9 (631)		2"
30RA030	19.60 (498)	38.98 (990)	73.0 (1854)	36.9 (936)		2"

NOTES:

- DO NOT CAP OR OTHERWISE OBSTRUCT THE LIQUID LINE TEMPERATURE RELIEF.
- Ø7/8 (22.4) PILOT HOLE PROVIDED FOR LOCATING FIELD POWER WIRING. ACTUAL HOLE REQUIRED DEPENDS ON FIELD WIRE SIZING.
- Ø0.437 (11.101) HOLE USED FOR MOUNTING UNIT.
- UNIT MUST HAVE CLEARANCES AS FOLLOWS:
 COIL SIDE - 42 (1067) FROM SOLID SURFACE.
 PANEL SIDE - 48 (1219) PER NEC.
- SEE TABLE COLUMN H; DIMENSION FOR STANDARD FAN OR VALUE SOUND FAN OPTION.
- CARRIER DOES NOT RECOMMEND INSTALLATION IN A PIT.
- UNIT CAN BE HANDLED USING THE FORK TRUCK LIFT POCKETS.
- WATER CONNECTIONS RECESSED 2 INCHES INSIDE UNIT.
 ALL WATER DRAIN AND VENTING HOLES ARE 1/4" NPT.

DIMENSIONS IN () ARE IN MILLIMETERS

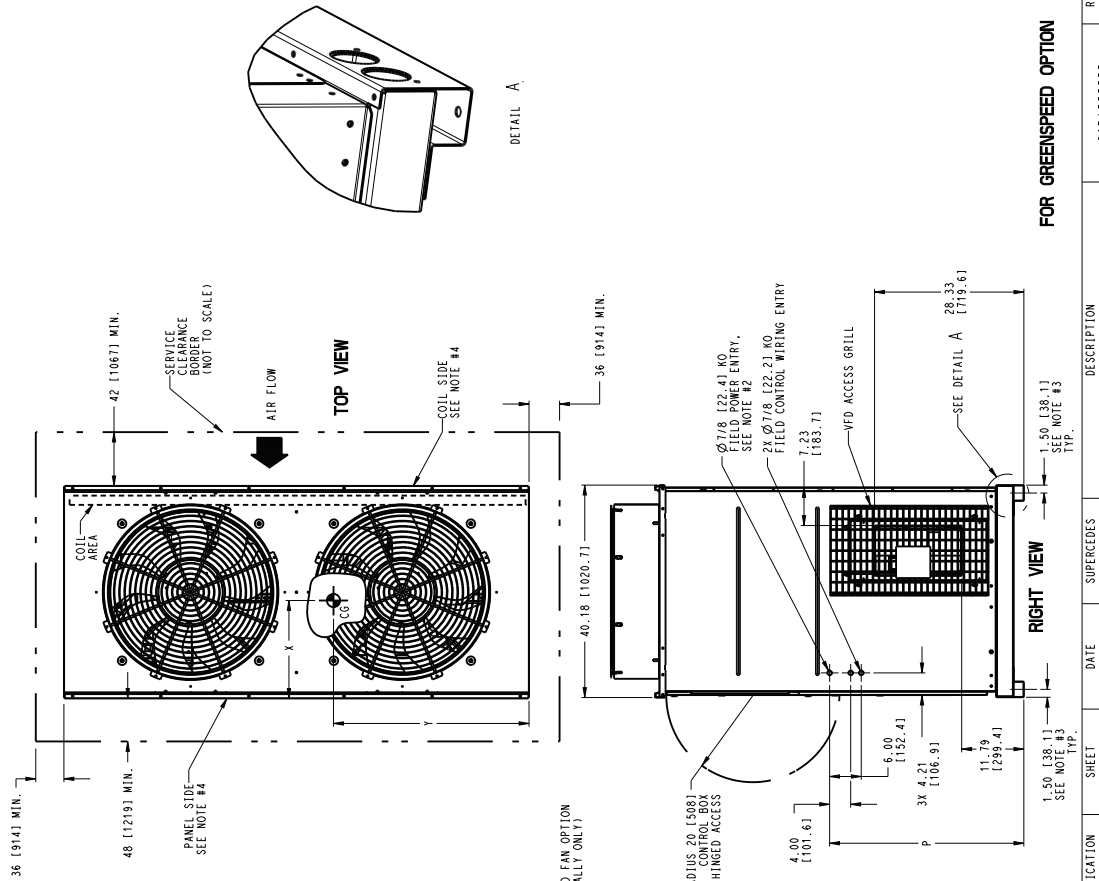

DETAIL A

FOR GREENSPEED OPTION

IITC CLASSIFICATION	SHEET	DATE	SUPERCEDES	DESCRIPTION	REV
U.S. ECCN:EAR99	2 OF 2	09/07/18	H	30RAP018-030 UNIT ASSY	I
				30RA555555	

Fig. 11 — Dimensions — 30RAP018-030 Units with Greenspeed® Intelligence

UNIT	CENTER OF GRAVITY		UNIT HEIGHT	WATER CONNECTION TO CARBON STEEL	
	X	Y		H (VALUE SOUND)	WATER IN/OUT
30RA035	36.45 [926]	146.08 [11170]	66.5 [1689]	61.0 [1549]	2-1/2"
30RA040	36.24 [921]	144.03 [11118]	66.5 [1689]	61.0 [1549]	2-1/2"
30RA045	36.24 [921]	146.15 [11172]	78.5 [1994]	73.0 [1854]	2-1/2"
30RA050	36.00 [914]	144.00 [11118]	78.5 [1994]	73.0 [1854]	2-1/2"
30RA055	36.48 [927]	144.60 [11133]	78.5 [1994]	73.0 [1854]	2-1/2"
30RA060	36.50 [927]	144.56 [11132]	78.5 [1994]	73.0 [1854]	2-1/2"

NOTES:

- DO NOT CAP OR OTHERWISE OBSTRUCT THE LIQUID LINE TEMPERATURE RELIEF.
- Ø7/8 [22.4] PILOT HOLE PROVIDED FOR LOCATING FIELD POWER WIRING. ACTUAL HOLE REQUIRED DEPENDS ON FIELD WIRE SIZING.
- Ø9.437 [11.10] HOLE USED FOR MOUNTING UNIT.
- UNIT MUST HAVE CLEARANCES AS FOLLOWS:
TOP - DO NOT RESTRICT FROM SOLID SURFACE.
COIL SIDE - 48 [1219] MIN.
PANEL SIDE - 48 [1219] PER REC.
- SEE TABLE COLUMN H; DIMENSION FOR STANDARD FAN OR VALUE SOUND FAN OPTION.
- CARRIER DOES NOT RECOMMEND INSTALLATION IN A PIT.
- UNIT CAN BE HANDLED USING THE FORK TRUCK LIFT POCKETS (MINIMUM OF 80" FORK LENGTH).
- WATER CONNECTIONS RECESSED 2-5/8" INCHES INSIDE UNIT. ALL WATER DRAIN AND VENTING HOLES ARE 1/4" NPT.

DIMENSIONS IN [] ARE IN MILLIMETERS

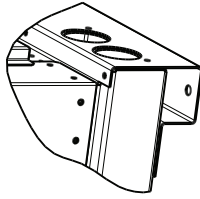
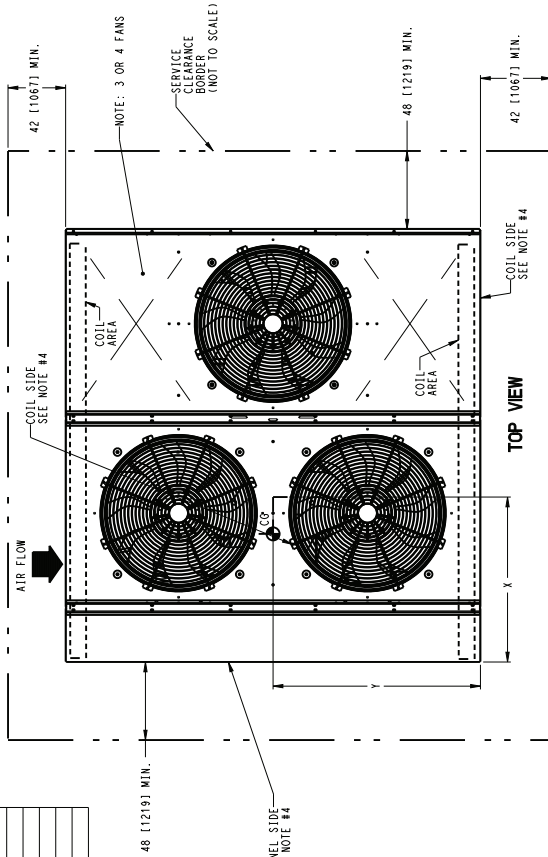

DETAIL A

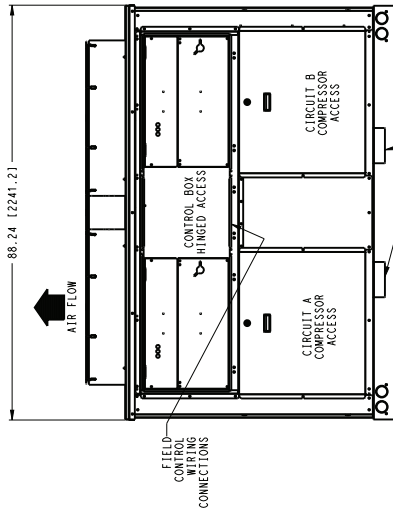

FRONT VIEW

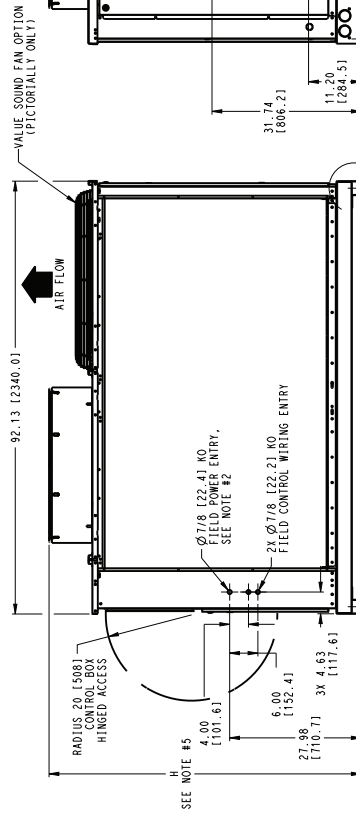

RIGHT VIEW

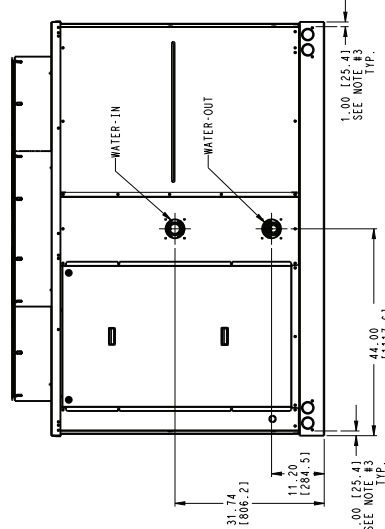

REAR VIEW

FOR LOW AMBIENT OPTION

DATE	09/10/715	SUPERSEDES	G	30RAP035-060 UNIT ASSY	30RA555556	REV	H
------	-----------	------------	---	------------------------	------------	-----	---

Fig. 12 — Dimensions — 30RAP035-060 Units with Fixed Speed Fans

UNIT	CENTER OF GRAVITY		UNIT HEIGHT		WATER CONNECTIONS (GREENSTEEL CARBON STEEL)	
	X	Y	H (STANDARD)	H (VALUE SOUND)	WATER IN/OUT	WATER IN/OUT
30RA035	36.45 [926]	46.08 [1170]	66.5 [1689]	61.0 [1549]	2-1/2"	2-1/2"
30RA040	36.24 [921]	44.03 [1119]	66.5 [1689]	61.0 [1549]	2-1/2"	2-1/2"
30RA045	36.24 [921]	46.15 [1172]	78.5 [1994]	73.0 [1854]	2-1/2"	2-1/2"
30RA050	36.00 [914]	44.00 [1119]	78.5 [1994]	73.0 [1854]	2-1/2"	2-1/2"
30RA055	36.48 [927]	44.60 [1133]	78.5 [1994]	73.0 [1854]	2-1/2"	2-1/2"
30RA060	36.50 [927]	44.56 [1132]	78.5 [1994]	73.0 [1854]	2-1/2"	2-1/2"

NOTES:

- DO NOT CAP OR OTHERWISE OBSTRUCT THE LIQUID LINE TEMPERATURE RELIEF.
- Ø7/8 (22.4) PILOT HOLE PROVIDED FOR LOCATING FIELD POWER WIRING. ACTUAL HOLE REQUIRED DEPENDS ON FIELD WIRE SIZING.
- Ø0.437 (11.1) HOLE USED FOR MOUNTING UNIT.
- UNIT MUST HAVE CLEARANCES AS FOLLOWS:
COIL SIDE - 42 (1067) MIN.
PANEL SIDE - 48 (1219) MIN.
- SEE TABLE COLUMN H: DIMENSION FOR STANDARD FAN OR VALUE SOUND FAN OPTION.
- CARRIER DOES NOT RECOMMEND INSTALLATION IN A PIT.
- UNIT CAN BE HANDLED USING THE FORK TRUCK LIFT POCKETS (MINIMUM OF 60" FORK LENGTH).
- WATER CONNECTIONS RECESSED 2-5/8 INCHES INSIDE UNIT. ALL WATER DRAIN AND VENTING HOLES ARE 1/4" NPT.

DIMENSIONS IN () ARE IN MILLIMETERS

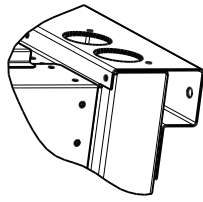
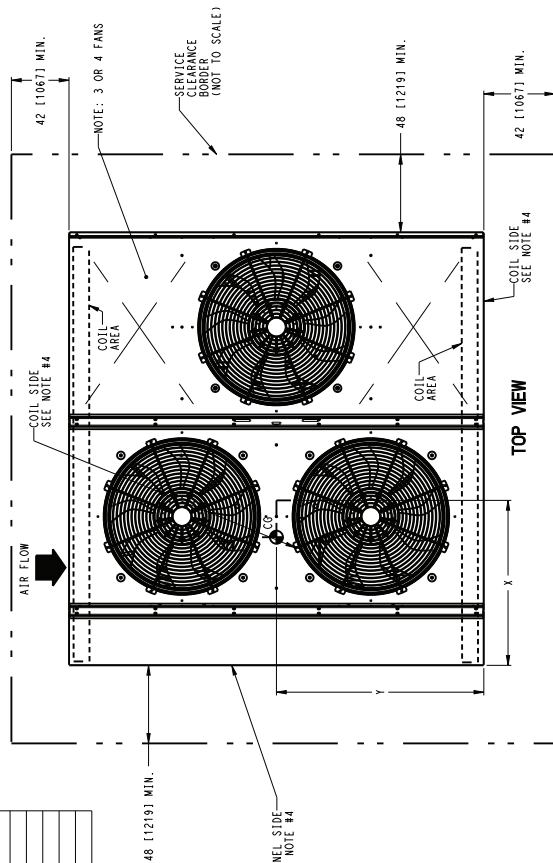

DETAIL A



RIGHT VIEW

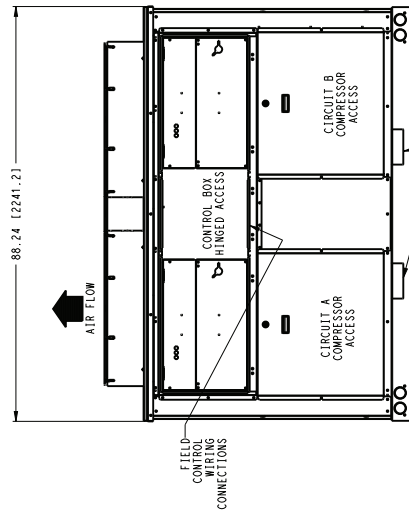

FRONT VIEW

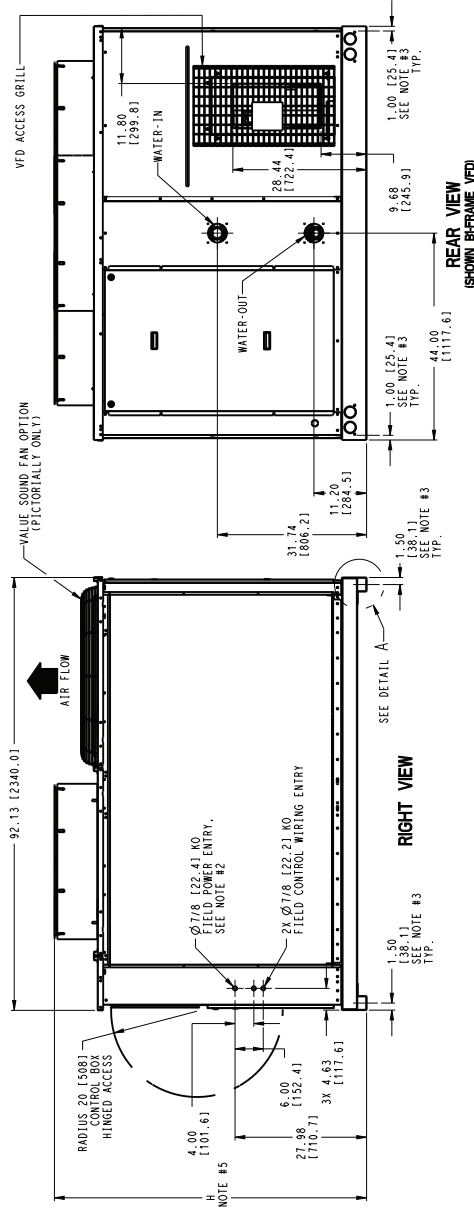

REAR VIEW
(SHOWN BIFRAME VFD)

FOR GREENSPEED OPTION

DATE	SUPPLIERS	UNIT ASSY	REV
09/07/15	G	30RAP035-060	H

Fig. 13 — Dimensions — 30RAP035-060 Units with Greenspeed® Intelligence

- NOTES: 1. UNIT MUST HAVE CLEARANCES AS FOLLOWS:
 TOP: DO NOT RESTRICT
 BOTTOM: 18" MIN. CLEARANCE FROM SOLID SURFACE FOR AIRFLOW
 SIDE: 8" REQUIRED FOR COIL SERVICE AREA
 SIDE: 8" REQUIRED FOR COIL SERVICE AREA
 2. ALL PUMPS HAVE DRAINS LOCATED AT THE BOTTOM OF VOLUME FOR DRAINING.
 3. TEMPERATURE RELIEF DEVICES LOCATED ON SUCTION LINE, LIQUID LINE AND
 LIQUID RETURN LINE. SEE NOTE #4 FOR LOCATION OF TEMPERATURE RELIEF DEVICES.
 4. TWO 60/180°Z FIELD CONTROL CHILERS PROVIDED FOR LOCATING FIELD POWER WIRING.
 5. ACTUAL HOLE REQUIRED DEPENDS ON FIELD WIRE SIZING.
 6. DIMENSIONS ARE IN INCHES. DIMENSIONS IN () ARE IN MILLIMETERS.
 7. 60/180°Z FIELD CONTROL CHILERS PROVIDED FOR LOCATING UNITS.
 8. 60/180°Z FIELD CONTROL CHILERS PROVIDED FOR LOCATING UNITS.
 9. IFS CARBON STEEL PIPING.

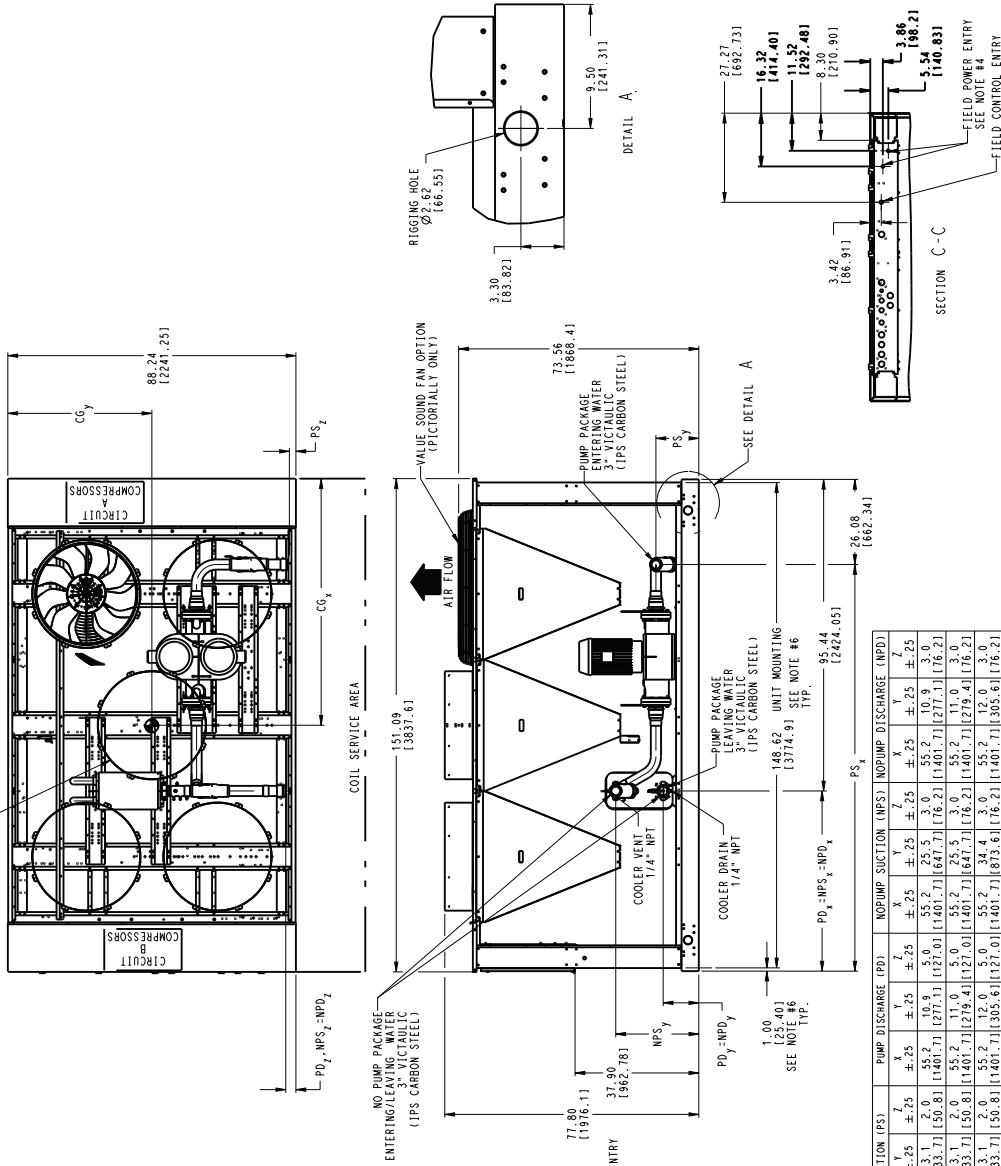

MODEL	MAX WEIGHT MCHX PUMP lb/kg	WEIGHT AL-CU PUMP lb/kg	MAX WEIGHT CU-CU PUMP lb/kg	WEIGHT PUMP lb/kg	CENTER OF GRAVITY CGx INCH (MM)	CGy INCH (MM)	PUMP SUCTION (FPS)			PUMP DISCHARGE (FPI)			NOPUMP SUCTION (NPS)			NOPUMP DISCHARGE (NPD)		
							X	Y	Z	X	Y	Z	X	Y	Z	X	Y	Z
30RAP-070	3356/1518	3705/1680	4340/1968	4305/1952	41.5 (1054)	85 (2159)	124.5 (3162.3)	13.1 (333.7)	2.0 (50.8)	55.2 (1401.7)	10.9 (277.1)	25.5 (647.7)	55.2 (1401.7)	25.5 (647.7)	55.2 (1401.7)	25.5 (647.7)	55.2 (1401.7)	25.5 (647.7)
30RAP-080	3522/1610	4067/1846	4815/2187	4663/2127	41.5 (1054)	85 (2159)	124.5 (3162.3)	13.1 (333.7)	2.0 (50.8)	55.2 (1401.7)	10.9 (277.1)	25.5 (647.7)	55.2 (1401.7)	25.5 (647.7)	55.2 (1401.7)	25.5 (647.7)	55.2 (1401.7)	25.5 (647.7)
30RAP-090	3655/1655	4310/1955	5028/2287	4663/2127	41.5 (1054)	85 (2159)	124.5 (3162.3)	13.1 (333.7)	2.0 (50.8)	55.2 (1401.7)	10.9 (277.1)	25.5 (647.7)	55.2 (1401.7)	25.5 (647.7)	55.2 (1401.7)	25.5 (647.7)	55.2 (1401.7)	25.5 (647.7)

DATE: 02/09/15
 SUPERSEDES: I
 30RAP-70, 80 AND 90 AIR COOLED CHILLERS
 30RA555557
 REV: J

Fig. 14 — Dimensions — 30RAP070-090 Units

NOTES: 1. UNIT MUST HAVE CLEARANCES AS FOLLOWS:

- TOP - DO NOT RESTRICT CLEARANCE FROM SOLID SURFACE, FOR AIRFLOW SIDES AND ENDS OF PUMP AND COMPRESSOR.
- ALL PUMPS HAVE DRAINS LOCATED AT THE BOTTOM OF VOLUME FOR DRAINING. TEMPERATURE RELIEF DEVICES LOCATED ON SUCTION LINE, LIQUID LINE AND FILTER DRAIN OF EACH CIRCUIT AND HAVE 1/4" FLARE CONNECTION.
- ACTUAL CLEARANCE FROM THE BOTTOM OF THE UNIT TO THE FIELD POWER WIRING. ACTUAL HOLE REQUIRED DEPENDS ON FIELD WIRE SIZING.
- ACTUAL HOLE REQUIRED DEPENDS ON FIELD WIRE SIZING.
- DIMENSIONS ARE IN INCHES - DIMENSIONS IN () ARE IN MILLIMETERS.
- Ø 1.524 (1.33) HOLE USED FOR MOUNTING UNITS.
- Ø 1.524 (1.33) HOLE USED FOR MOUNTING UNITS.
- IPS CARBON STEEL PIPING.

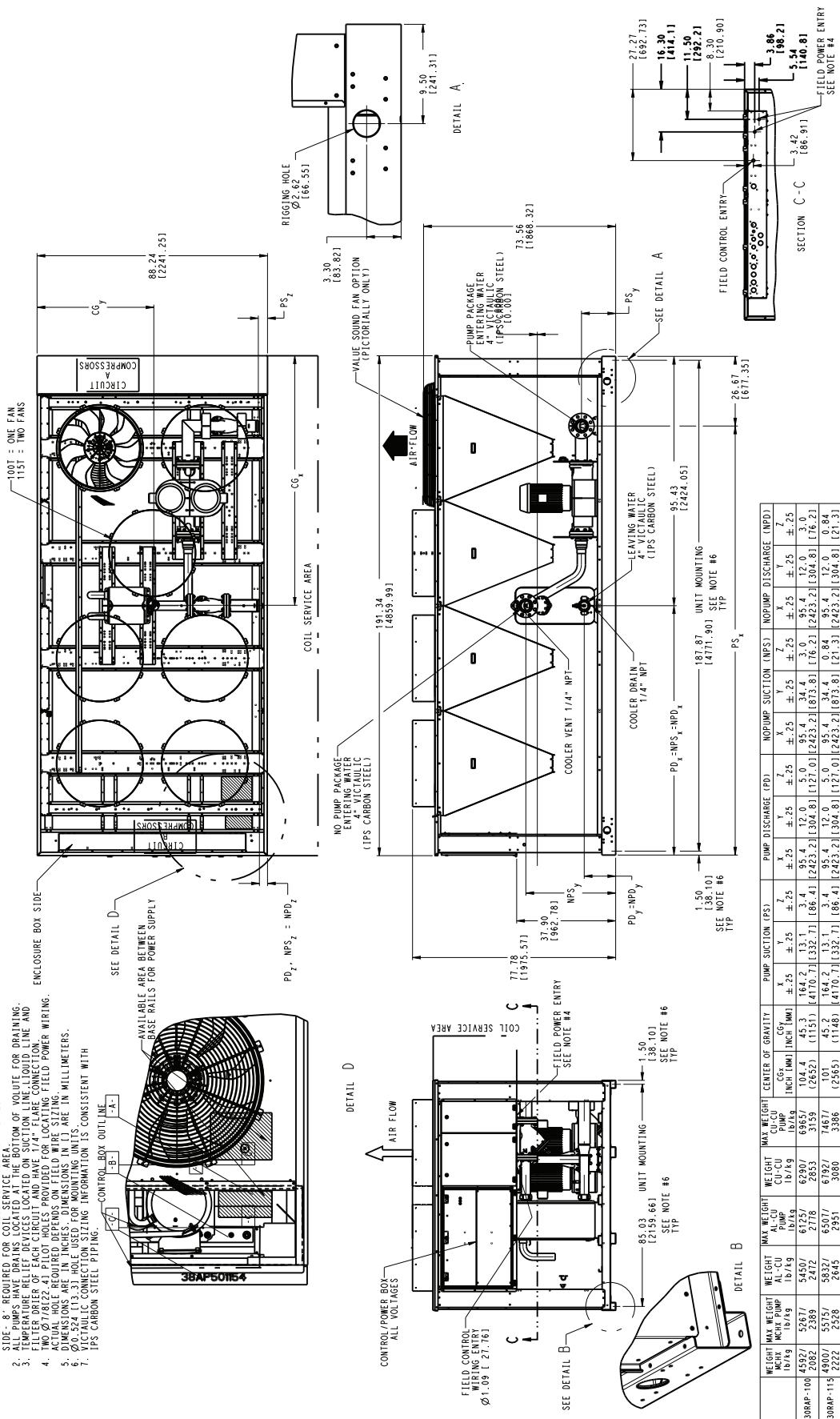

WEIGHT 10/19	MAX WEIGHT 10/19	WEIGHT 10/19	MAX WEIGHT 10/19	CENTER OF GRAVITY		PUMP SUCTION (FPS)			PUMP DISCHARGE (FPD)			NO PUMP SUCTION (MPS)			NO PUMP DISCHARGE (MPD)		
				INCH	MM	X	Y	Z	X	Y	Z	X	Y	Z	X	Y	Z
4932/10/19	5287/10/19	5407/10/19	6129/10/19	104.7	(2672)	±.25	±.25	±.25	±.25	±.25	±.25	±.25	±.25	±.25	±.25	±.25	±.25
4932/10/19	5287/10/19	5407/10/19	6129/10/19	104.7	(2672)	±.25	±.25	±.25	±.25	±.25	±.25	±.25	±.25	±.25	±.25	±.25	±.25
4907/10/19	5257/10/19	5327/10/19	6097/10/19	104.7	(2672)	±.25	±.25	±.25	±.25	±.25	±.25	±.25	±.25	±.25	±.25	±.25	±.25
2222	2328	2445	2951	104.7	(2672)	±.25	±.25	±.25	±.25	±.25	±.25	±.25	±.25	±.25	±.25	±.25	±.25

DATE: 02/06/15
 SUPERSEDES: F
 30RAP-100 AND 115 AIR COOLED CHILLER
 30RA555538
 REV: G

Fig. 15 — Dimensions — 30RAP100,115 Units

- NOTES: 1. UNIT MUST HAVE CLEARANCES AS FOLLOWS:
 TOP - DO NOT RESTRICT.
 SIDES AND END - 6" FROM SOLID SURFACE FOR AIRFLOW.
 2. SIDE PANELS ARE REQUIRED FOR COIL SERVICE AREA BOTTOM OF VOLUTE FOR BRACING.
 3. TEMPERATURE-RELIEF DEVICES LOCATED ON SUCTION LINE LIQUID LINE AND
 FILTER DRIER OF EACH CIRCUIT AND HAVE 1/4" FLARE CONNECTION.
 4. TWO Ø 7/8 (22.4) PILOT HOLES PROVIDED FOR LOCATING FIELD POWER WIRING.
 5. DIMENSIONS ARE IN INCHES. DIMENSIONS IN () ARE IN MILLIMETERS.
 6. Ø 0.524 (13.31) HOLE USED FOR MOUNTING UNITS.
 7. VICTAULIC CONNECTION SIZING INFORMATION IS CONSISTENT WITH
 VICTAULIC CONNECTION SIZING INFORMATION.

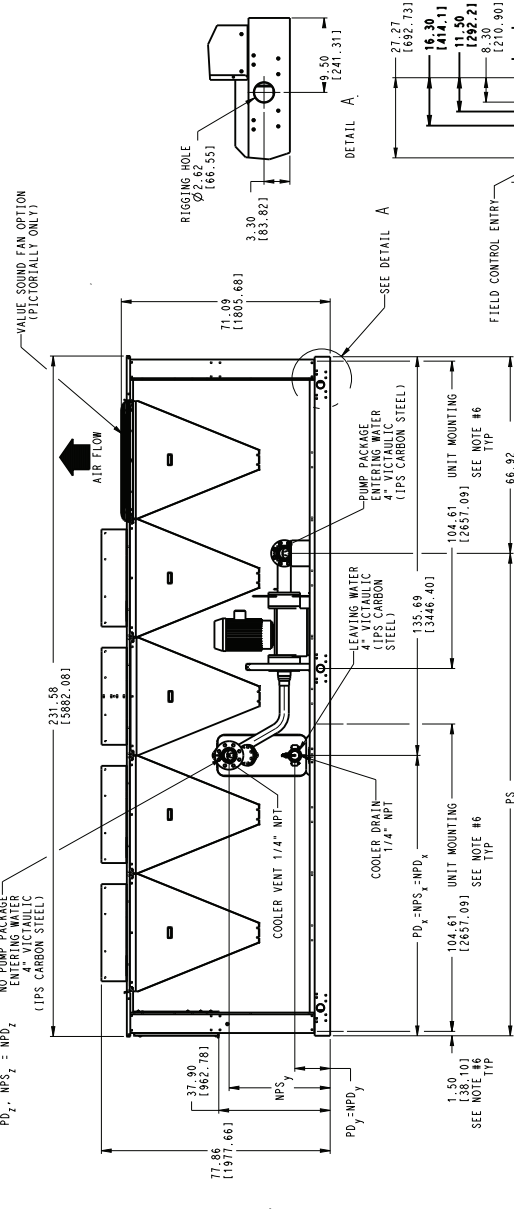
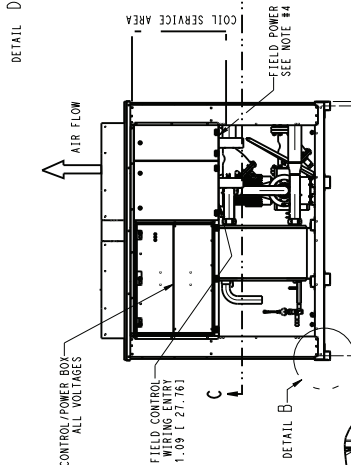
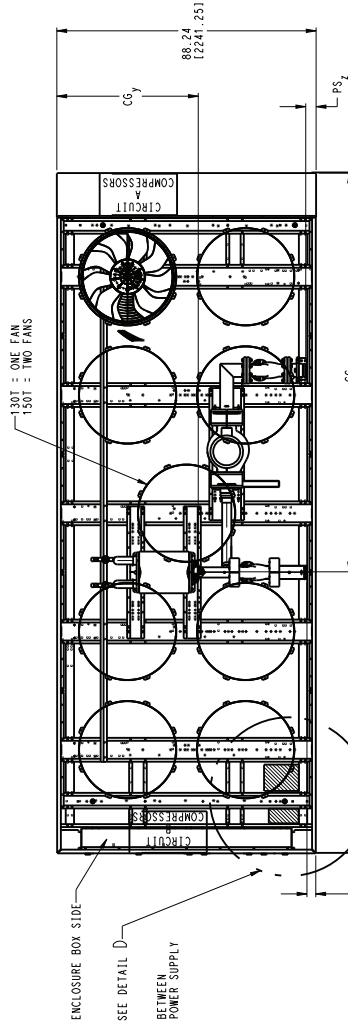

WEIGHT NCH lb/kg	MAX WEIGHT MCH lb/kg	WEIGHT AL-CU lb/kg	WEIGHT PUMP lb/kg	MAX WEIGHT PUMP lb/kg	CENTER OF GRAVITY INCH (MM)	PUMP SUCTION (FPS)			PUMP DISCHARGE (FPD)			NO PUMP SUCTION (NPS)			NO PUMP DISCHARGE (NPD)			
						X	Y	Z	X	Y	Z	X	Y	Z	X	Y	Z	
6335	7010	6997	7672	8077	127.7	42.9	164.2	13.1	3.4	95.4	12.0	5.0	95.4	34.4	3.0	95.4	12.0	3.0
(2813)	(3179)	(3179)	(3419)	(3743)	(3243)	(1089)	(4170.7)	(332.7)	(86.4)	(2423.2)	(304.8)	(177.0)	(4243.2)	(176.2)	(2423.2)	(304.8)	(176.2)	(176.2)
6810	7485	7545	8207	8745	123.9	43.0	154.2	3.4	3.4	95.4	12.0	5.0	95.4	34.4	0.53	95.4	12.0	0.53
(3088)	(3394)	(3422)	(3728)	(3966)	(3147)	(1092)	(4170.7)	(86.4)	(86.4)	(2423.2)	(304.8)	(177.0)	(4243.2)	(173.3)	(2423.2)	(304.8)	(173.3)	(173.3)

Y. 13.1 (332.7) FOR DUAL PUMP AND 15.6 (396.2) FOR SINGLE PUMP

DATE	02/06/15	REV	G
SUPERCEDS	F		
		30RAP-130 AND 150 AIR COOLED CHILLER	30RA55559

Fig. 16 — Dimensions — 30RAP130,150 Units

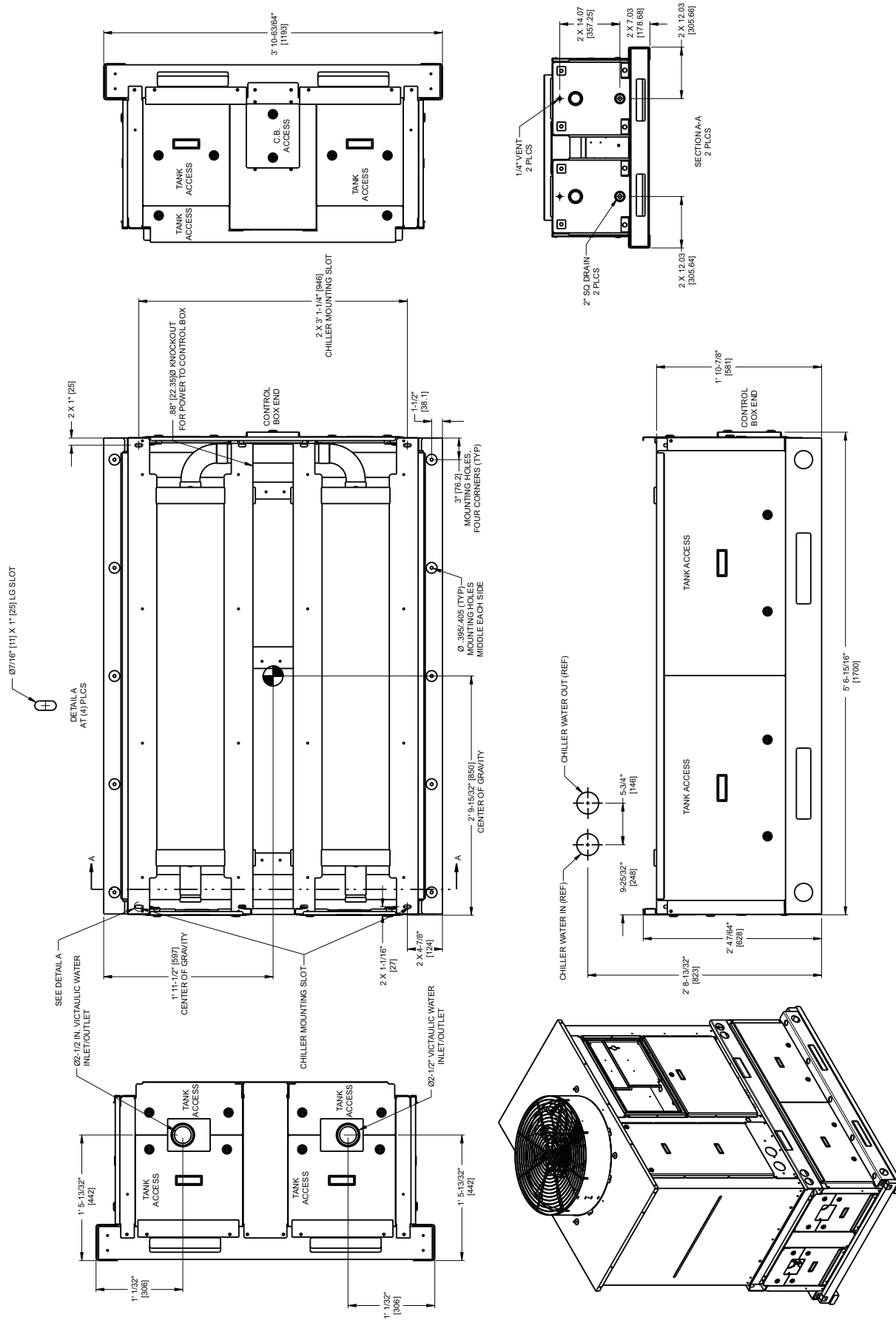

Fig. 17 — Accessory Storage Tank 30RA-900-050 Dimensions — 30RAP011,016 Units

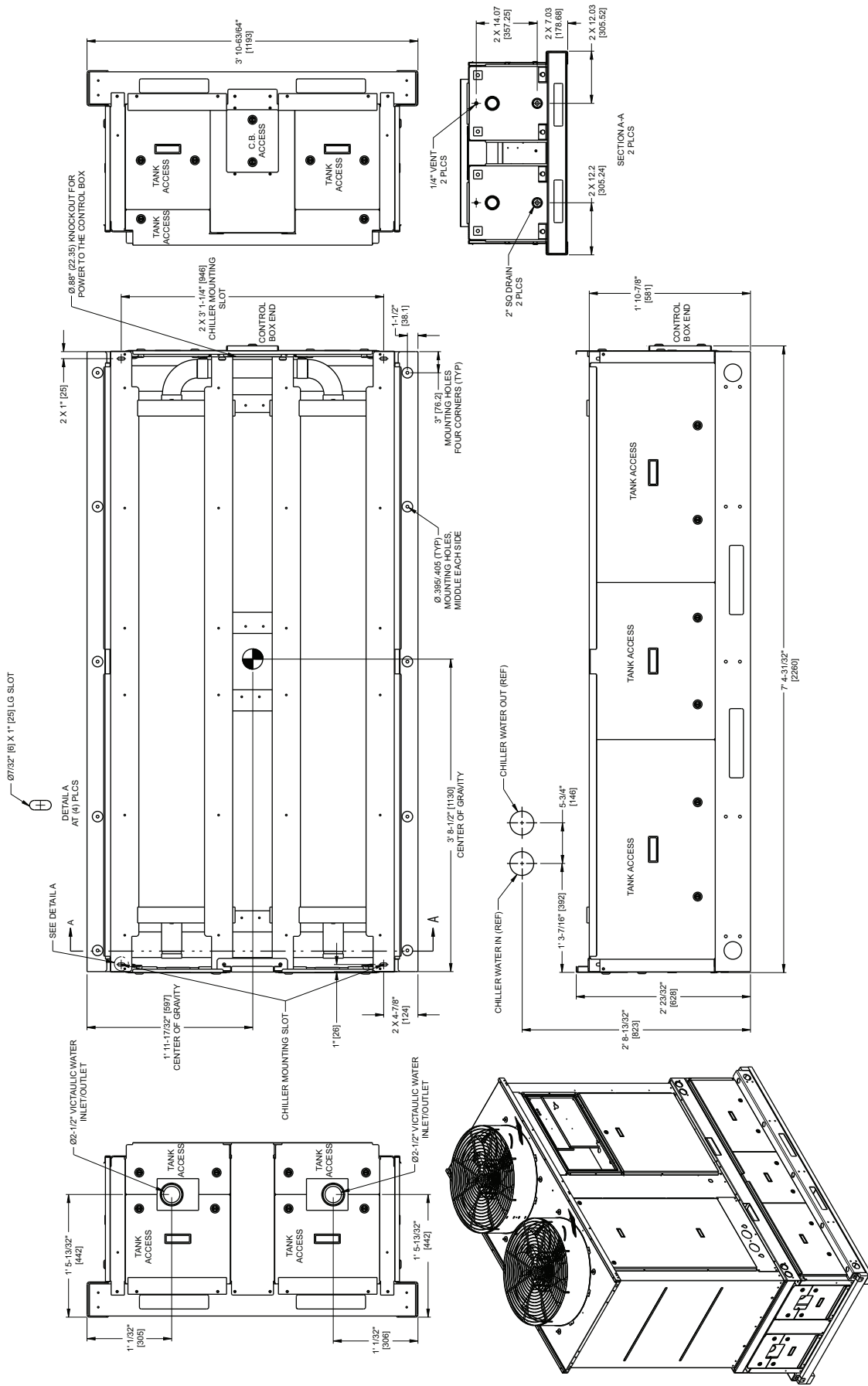

Fig. 18 — Accessory Storage Tank 30RA-900-051 Dimensions — 30RAP018-030 Units

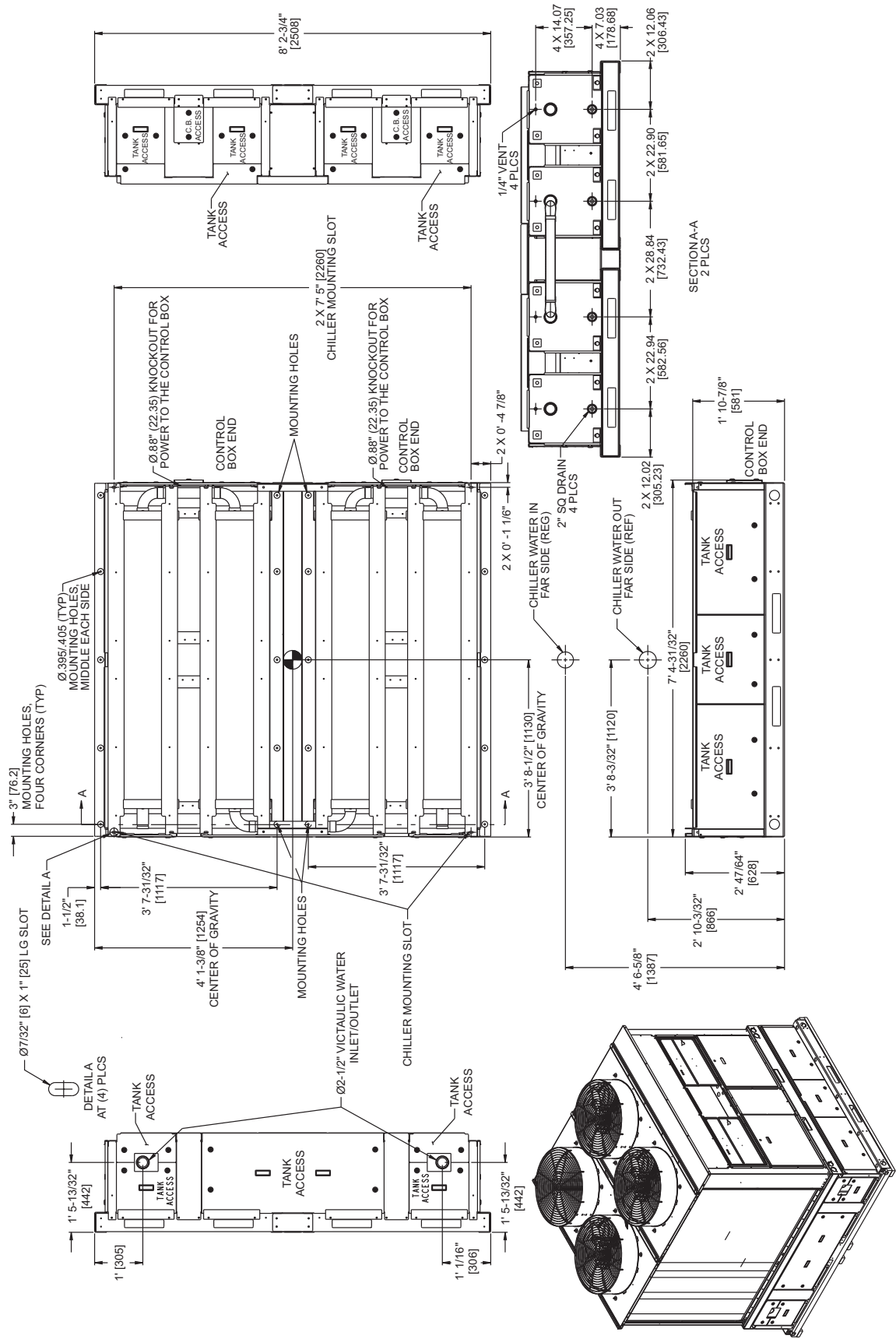

Fig. 19 — Accessory Storage Tank 30RA-900-052 Dimensions — 30RAP035-060 Units

Dual Chiller Control Option — If the dual chiller algorithm is utilized the machines must be installed in parallel. An additional chilled water sensor must be installed. Install the well in the common leaving water header. See Fig. 20 and 21.

Parallel chiller control with dedicated pumps is recommended. Chiller must start and stop its own water pump located in its own piping. If pumps are not dedicated for each chiller, then isolation valves are required. Each chiller must open and close its own isolation valve through the unit control (the valve must be connected to the pump outputs). See Fig. 21.

Do not relocate the chiller's leaving water thermistors. They must remain in place for the unit to operate properly. The thermistor well is a 1/4-in. NPT fitting for mounting the well in the piping. Select a location that will allow for removal of the thermistor without any restrictions. Once the well is installed, insert the thermistor into the well utilizing thermal conductive grease. Once the thermistor is in place, it is recommended that a thermistor wire loop be made and secured with a wire tie to the well. Attach the dual leaving water temperature thermistor to LVT-22 and 23. A Carrier Comfort Network® (CCN) bus

must be connected between the two chillers. For more information regarding Communication Bus Wiring, see the Carrier Comfort Network® (CCN) Interface section of the Controls, Start-Up, Operation, Service, and Troubleshooting guide.

PART NUMBER	DIMENSIONS in. (mm)	
	A	B
10HB50106801	3.10 (78.7)	1.55 (39.4)
10HB50106802	4.10 (104.1)	1.28 (32.5)

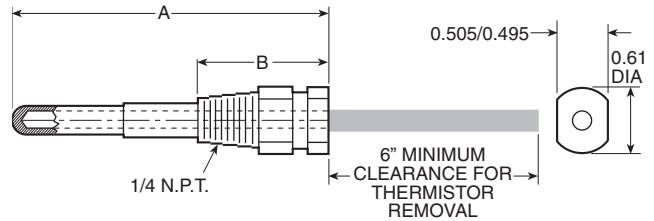
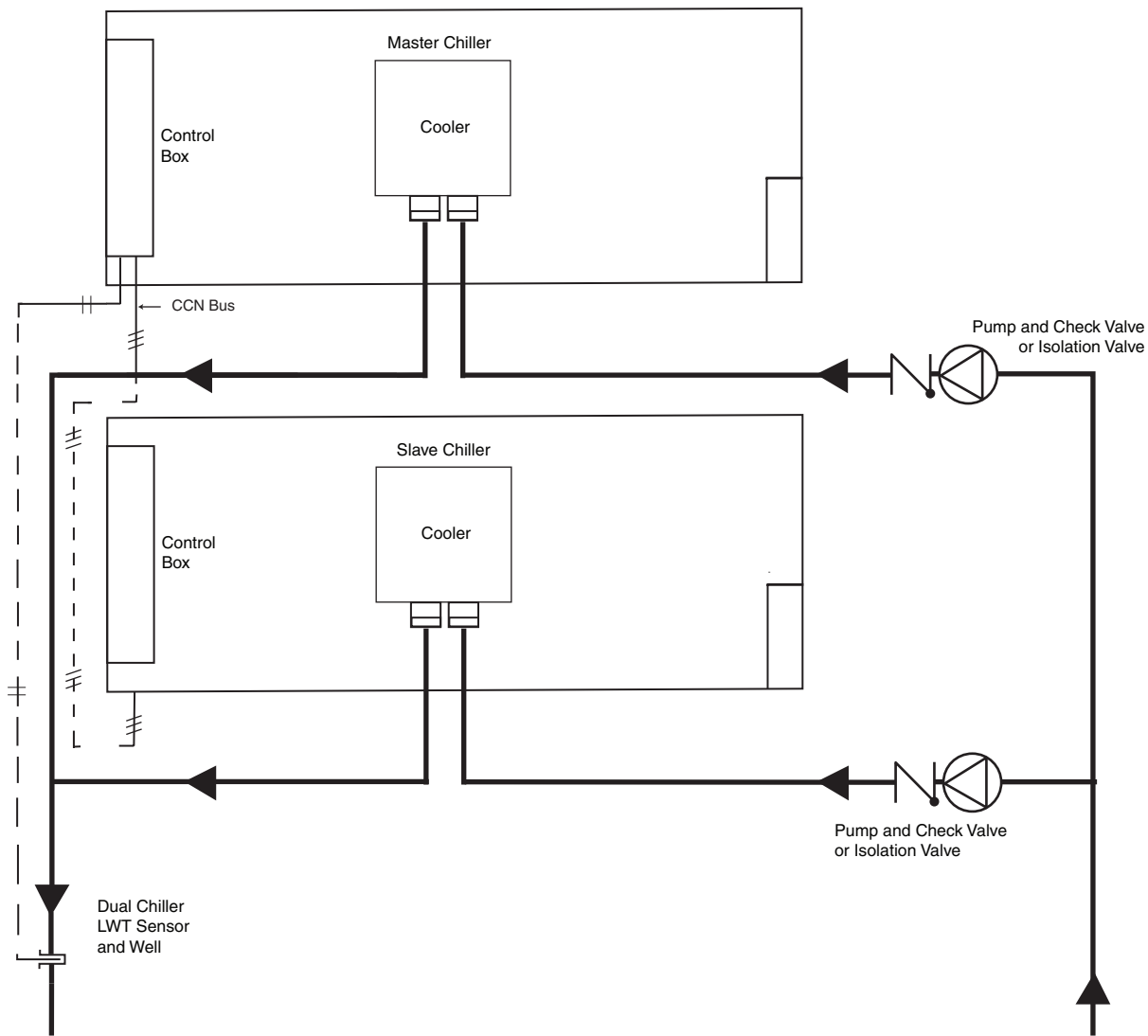

Fig. 20 — Dual Leaving Water Thermistor Well



Depending on piping sizes, use either:

- HH79NZ014 sensor/10HB50106801 (3-in. sensor/well)
- HH79NZ029 sensor/10HB50106802 (4-in. sensor/well)

NOTE: This is a simplified piping diagram—not all hydronic specialties are shown.

LEGEND
 LWT — Leaving Water (Fluid) Temperature
 —||— Field Wiring
 -#-#- Field Communication Wiring

Fig. 21 — Dual Chiller Piping Diagram

VICTAULIC COUPLING INSTALLATION

1. The outside surface of the pipe, between the groove and the pipe end, must be smooth and free from indentations, projections (including weld seams), and roll marks to ensure a leak-tight seal. All oil, grease, loose paint, and dirt must be removed.
2. Apply a thin coat of Victaulic lubricant or silicone lubricant to the gasket sealing lips and exterior.

⚠ CAUTION

Always use a compatible lubricant to prevent the gasket from pinching or tearing during installation. Failure to follow this instruction could result in joint leakage.

3. Position the gasket over the pipe end. Make sure the gasket does not overhang the pipe end.
4. Align and bring the two pipe ends together. Slide the gasket into position and center it between the groove in each pipe end. Make sure no portion of the gasket extends into the groove in either pipe end.
5. Install the housings over the gasket.
NOTE: Make sure the housings' keys engage the grooves completely on both pipe ends.

⚠ CAUTION

Make sure the gasket does not become rolled or pinched while installing the housings. Failure to follow this instruction could cause damage to the gasket, resulting in joint leakage.

6. Install the bolts, and thread a nut finger-tight onto each bolt. For couplings supplied with stainless steel hardware, apply an anti-seize compound to the bolt threads. Make sure the oval neck of each bolt seats properly in the bolt hole.
7. Tighten the nuts evenly by alternating sides until metal-to-metal contact occurs at the bolt pads. Make sure the housings' keys engage the grooves completely.
NOTE: It is important to tighten the nuts evenly to prevent gasket pinching.
8. Visually inspect the bolt pads at each joint to ensure metal-to-metal contact is achieved.

UNITS WITH FACTORY-INSTALLED HYDRONIC PACKAGES — The 30RAP chillers with factory-installed hydronic packages are designed for use with closed systems, meaning that there is no more than one water-air interface in the water loop. Cooling tower loops, for example, have two water-air interfaces (sump and nozzles) and would thus be classified as open, whereas a correctly designed chilled water loop with the only water-air interface being in the expansion tank is closed. Since closed and open water systems behave very differently, these instructions assume that the chilled water loop is closed. A system installed incorrectly such that air is not handled properly — pipe leaks, vent leaks, air in pipes, etc. — may behave as an open system and thus have unsatisfactory operation. Pump seal wear can also cause leaks that cause poor system operation.

Proper closed system design and installation procedures should be followed closely. The system must be constructed with pressure-tight components and thoroughly tested for installation leaks. Factory-supplied hydronic systems are available with single or dual (for back-up) pumps.

Figure 22 shows a typical installation with components that might be installed with the hydronic package of the 30RAP unit. The factory-installed system includes all of the components within the dashed lines. Figure 23 illustrates a typical dual pump package for the 011-030 size models.

NOTE: For units with single pumps, it is recommended that isolation (shutoff) valves be placed exterior to the unit to allow removal and service of the entire pump assembly, if necessary. Units with dual pumps have pump isolation valves provided. Also, if the unit is isolated with valves, a properly sized pressure relief valve should be installed in the piping between the unit and the valves, following all applicable state and local codes.

System Pressurization — A proper initial cold fill pressure must be established before the filling of the unit. The initial cold fill pressure is the pressure applied at the filling point to fill a system to its highest point, plus a minimum pressure at the top of the system (4 psi [28 kPa] minimum) to operate air vents and positively pressurize the system.

The compression tank (sometimes called expansion tank) is very important to system pressurization. The compression tank actually serves several purposes:

1. Provides net positive suction head required (NPSHR) for the pump to operate satisfactorily.
2. Sets system pressure.
3. Accommodates expansion/contraction of water due to temperature changes.
4. Acts as a pressure reference for the pump.

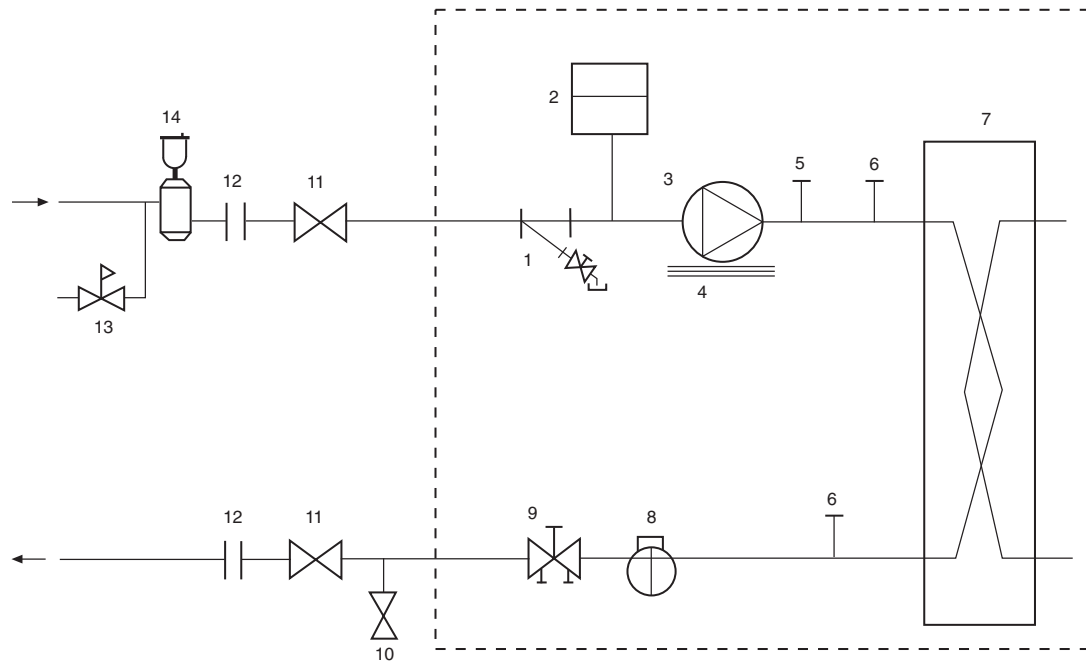

LEGEND

- | | | |
|---|-----------------------------------|----------------------|
| 1 — Strainer/Blow-Down Valve | 8 — Flow Switch | --- Factory Supplied |
| 2 — Expansion Tank (011-060 sizes only) | 9 — Balance Valve/Drain Plug | |
| 3 — Pump | 10 — Pressure Relief | |
| 4 — Electric Heater | 11 — Isolation Valves | |
| 5 — Air Vent Connection Port | 12 — Flex Connections | |
| 6 — Pressure/Temperature Access Port | 13 — Pressure Reducing/Fill Valve | |
| 7 — Heat Exchanger | 14 — Air Separator and Vent | |

Fig. 22 — Typical Piping Diagram — 30RAP Units with Hydronic Package

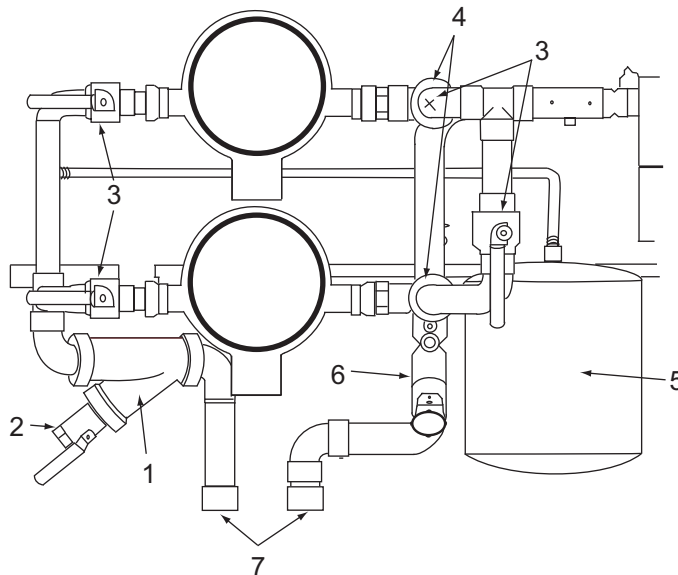

LEGEND

- | | |
|---|-------------------------------------|
| 1 — Strainer | 5 — Expansion Tank |
| 2 — Blow-Down Valve | 6 — Balancing Valve with Drain Plug |
| 3 — Service Valves | 7 — Field Connections |
| 4 — Discharge Check Valve (Dual Pumps Only) | |

Fig. 23 — Typical Dual Pump Package (011-030 sizes only)

The compression tank pressure must be set BEFORE the system is filled. Expansion tanks are factory supplied on sizes 011-060 only and field supplied on all other sizes. The tanks are pre-charged at the factory to 40 psig (276 kPa). If the 30RAP unit with expansion tank is the high point in the system, tank pre-charge pressure of 40 psig (276 kPa) will be adequate. If the 30RAP unit with expansion tank is NOT at the high point in the system, then the minimum pre-charge pressure for the water system must be determined using Table 8 and the method below:

$$\text{Tank Pressure} = 4 + (\text{height from tank to top of system in feet} \times "X")$$

$$[27.6 + (\text{height in m} \times 22.6 / "X")]$$

For example, assuming a system containing a 20% concentration of ethylene glycol and 50 ft (15.2 m) in height from the top of the system to the expansion tank, the minimum tank pre-charge pressure would be:

$$\text{Tank Pressure} = 4 + (50 / 2.38) = 25.0 \text{ psig}$$

$$= 27.6 + (15.2 \times 22.6 / 2.38) = 171.9 \text{ kPa}$$

Table 8 — “X” Factor for Setting Tank Pressure

% GLYCOL	ETHYLENE GLYCOL	PROPYLENE GLYCOL
0 (pure water)	2.31	2.31
10	2.36	2.33
20	2.38	2.36
30	2.40	2.38
40	2.43	2.38
50	2.47	2.40

NOTE: If expansion tanks are placed elsewhere in the system this method cannot be used since extra pressure drop between the tank and the pump must be accounted for.

NOTE: If the system requires a pre-charge greater than 40 psig (276 kPa), increase pressure as described below.

Expansion Tank Pre-Charge — To pre-charge the expansion tank, do the following steps:

1. Check the tank air pressure at the pre-charge connection with an accurate pressure gage. Adjust as needed.
2. If additional pressure is required, charge the tank with oil-free compressed air or nitrogen gas. Occasionally check the pressure as when filling a tire.
3. Check the air valve for leakage. If it leaks, relieve the pressure and replace the core with a Schrader-type tire core. DO NOT depend on the valve cap to seal the leak.

Once the system is pressurized, the pressure at the connection point of the expansion tank to water piping will not change unless the water loop volume changes (either due to addition/subtraction of water or temperature expansion/contraction). The pressure at this point remains the same regardless of whether or not the pump is running.

Since the expansion tank acts as a reference point for the pump, there cannot be two reference points (two expansion tanks) in a system (unless manifolded together). If system volume or other design considerations warrant the placement of another expansion tank somewhere in the system, the expansion tank in the 30RAP hydronic package MUST be disconnected from its hose and the end of the hose securely plugged.

This is also true for applications where two or more 30RAP chillers are placed in parallel. There should not be more than

one expansion tank in the system (as seen in Fig. 23) unless manifolded together. When multiple 30RAP chillers are applied in parallel, and the chillers include the optional hydronic package which contain expansion tanks (sizes 011-060), the expansion tanks must be disconnected from the 30RAP hydronic package. It is permissible to install the expansion tank(s) in a portion of the return water line that is common to all pumps, providing that the tank is properly sized for combined system volume.

If the application involves two or more chillers in a primary/secondary system, a common place for mounting the expansion tank is in the chilled water return line, just before the decoupler. Refer to Fig. 24 for placement of expansion tank in primary/secondary systems.

The expansion tank included in the 30RAP hydronic package is a diaphragm tank, meaning that a flexible diaphragm physically separates the water/air interface. With this type of expansion tank, it is undesirable to have any air in the water loop. See the section on air separation below for instructions on providing air separation equipment.

AIR SEPARATION — For proper system operation, it is essential that water loops be installed with proper means to manage air in the system. Free air in the system can cause noise, reduce terminal output, stop flow, or even cause pump failure due to pump cavitation. For closed systems, equipment should be provided to eliminate all air from the system.

The amount of air that water can hold in solution depends on the pressure and temperature of the water/air mixture. Air is less soluble at higher temperatures and at lower pressures. Therefore, separation can best be done at the point of highest water temperature and lowest pressure. Typically, this point would be on the suction side of the pump as the water is returning from the system or terminals. Generally speaking, this is the best place to install an air separator, if possible.

1. Install automatic air vents at all high points in the system. (If the 30RAP unit is located at the high point of the system, a vent can be installed on the piping entering the heat exchanger on the 1/4-in. NPT female port.)
2. Install an air separator in the water loop, at the place where the water is at higher temperatures and lower pressures — usually in the chilled water return piping. On a primary-secondary system, the highest temperature water is normally in the secondary loop, close to the decoupler. Preference should be given to that point on the system (see Fig. 24). In-line or centrifugal air separators are readily available in the field.

It may not be possible to install air separators at the place of lowest pressure and highest temperature. In such cases, preference should be given to the points of highest temperature. It is important that pipe be sized correctly so that free air can be moved to the point of separation. Generally, a water velocity of at least 2 ft (610 mm) per second will keep free air entrained and prevent it from forming air pockets.

Automatic vents should be installed at all physically elevated points in the system so that air can be eliminated during system operation. Provision should also be made for manual venting during the water loop fill. It is important that the automatic vents be located in accessible locations for maintenance purposes, and that they be located where they can be prevented from freezing.

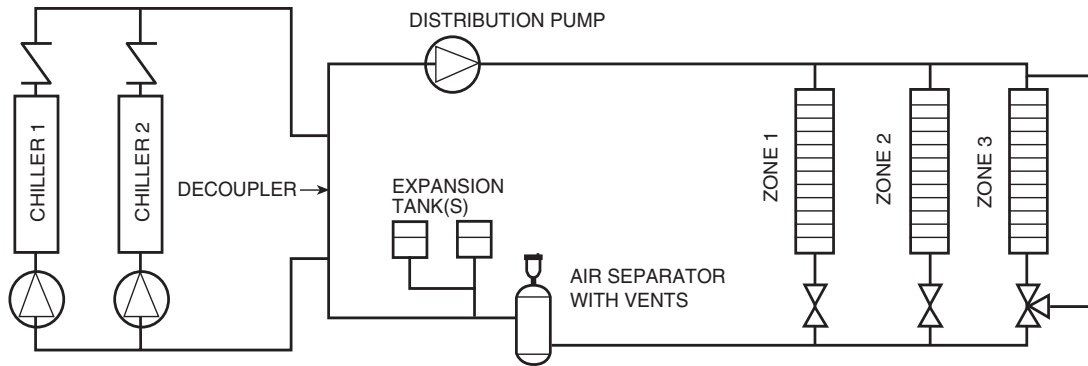

NOTE: Expansion tanks in the 30RAP hydronic kits must be disconnected for chillers placed parallel in the primary water loop.

Fig. 24 — Typical Air Separator and Expansion Tank Location on Primary-Secondary Systems

Step 4 — Fill the Chilled Water Loop

WATER SYSTEM CLEANING — Proper water system cleaning is of vital importance. Excessive particulates in the water system can cause excessive pump seal wear, reduce or stop flow, and cause damage of other components. Water quality should be maintained within the limits indicated in Table 9. Failure to maintain proper water quality may result in heat exchanger failure.

CAUTION

Failure to properly clean all piping and components of the chilled water system before unit start-up may result in plugging of the heat exchanger, which can lead to poor performance, nuisance alarms, and damage from freezing. Freezing damage caused by an improperly cleaned system represents abuse and may impair or otherwise negatively affect the Carrier product warranty.

1. Install a temporary bypass around the chiller to avoid circulating dirty water and particulates into the pump package and chiller during the flush. Use a temporary circulating pump during the cleaning process. Also, be sure that there is capability to fully drain the system after cleaning. (See Fig. 25.)
2. Be sure to use a cleaning agent that is compatible with all system materials. Be especially careful if the system contains any galvanized or aluminum components. Both detergent-dispersant and alkaline-dispersant cleaning agents are available.
3. It is a good idea to fill the system through a water meter. This provides a reference point for the future for loop volume readings, and it also establishes the correct quantity of cleaner needed in order to get the required concentration.
4. Use a feeder/transfer pump to mix the solution and fill the system. Circulate the cleaning system for the length of time recommended by the cleaning agent manufacturer.
 - a. After cleaning, drain the cleaning fluid and flush the system with fresh water.
 - b. A slight amount of cleaning residue in the system can help keep the desired, slightly alkaline, water pH of 8 to 9. Avoid a pH greater than 10, since this will adversely affect pump seal components.
 - c. A side stream filter is recommended (see Fig. 26) during the cleaning process. Filter side flow rate should be enough to filter the entire water volume

every 3 to 4 hours. Change filters as often as necessary during the cleaning process.

- d. Remove temporary bypass when cleaning is complete.

A 40-mesh strainer with a blow-down valve is standard on all 30RAP units, both with and without hydronic packages. The blow-down valve allows removal of particulates caught in the strainer without complete removal of the screen. A female NPT connection is provided on the valve, allowing hose connection for drainage outside the unit.

Carrier's *ComfortLink* controls have a built-in feature to remind building owners or operators to clean the strainer by discharging the blow-down valve at a pre-set time interval. Properly installed and cleaned systems will rarely need the strainer cleaned after the initial fill. This time interval is user-configurable.

Table 9 — Water Quality Characteristics and Limitations

WATER CHARACTERISTIC	QUALITY LIMITATION
Alkalinity (HCO ₃ ⁻)	70 – 300 ppm
Sulfate (SO ₄ ²⁻)	Less than 70 ppm
HCO ₃ ⁻ /SO ₄ ²⁻	Greater than 1.0
Electrical Conductivity	10 – 500 µS/cm
pH	7.5 – 9.0
Ammonia (NH ₃)	Less than 2 ppm
Chlorides (Cl ⁻)	Less than 300 ppm
Free chlorine (Cl ₂)	Less than 1 ppm
Hydrogen Sulfide (H ₂ S)*	Less than 0.05 ppm
Free (aggressive) Carbon Dioxide (CO ₂)†	Less than 5 ppm
Total Hardness (°dH)	4.0 – 8.5
Nitrate (NO ₃)	Less than 100 ppm
Iron (Fe)	Less than 0.2 ppm
Aluminum (Al)	Less than 0.2 ppm
Manganese (Mn)	Less than 0.1 ppm

*Sulfides in the water quickly oxidize when exposed to air, requiring that no agitation occur as the sample is taken. Unless tested immediately at the site, the sample will require stabilization with a few drops of one Molar zinc acetate solution, allowing accurate sulfide determination up to 24 hours after sampling. A low pH and high alkalinity cause system problems, even when both values are within the ranges shown. The term pH refers to the acidity, basicity, or neutrality of the water supply. Below 7.0, the water is considered to be acidic. Above 7.0, water is considered to be basic. Neutral water contains a pH of 7.0.

†Dissolved carbon dioxide can either be calculated from the pH and total alkalinity values, shown below, or measured on the site using a test kit. Dissolved Carbon Dioxide, PPM = TA × 2^[(6.3-pH)/0.3] where TA = Total Alkalinity, PPM as CaCO₃.

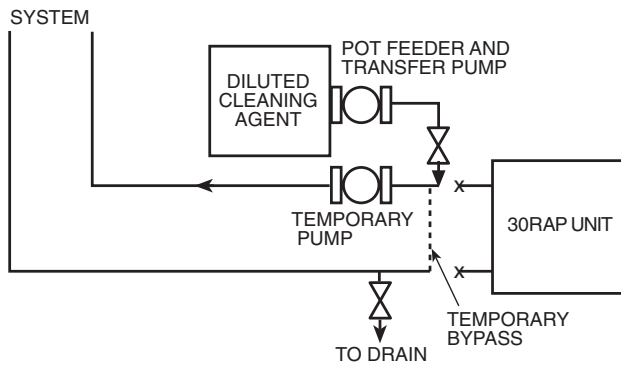

Fig. 25 — Typical Set Up for Cleaning Process

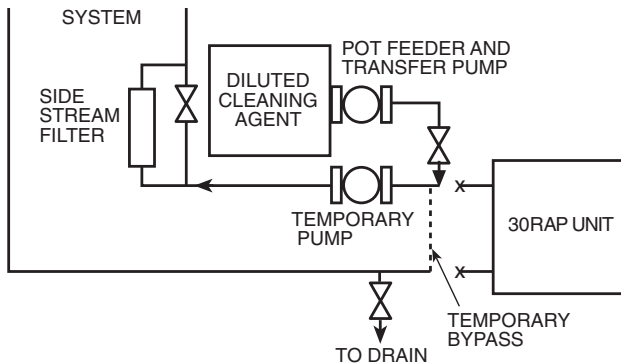

Fig. 26 — Cleaning Using a Side Stream Filter

FILLING THE SYSTEM — The initial fill of the chilled water system must accomplish three purposes:

1. The entire piping system must be filled with water.
2. The pressure at the top of the system must be high enough to vent air from the system (usually 4 psig [28 kPa] is adequate for most vents).
3. The pressure at all points in the system must be high enough to prevent flashing in the piping or cavitation in the pump.

The pressure created by an operating pump affects system pressure at all points except one — the connection of the compression tank to the system. This is the only location in the system where pump operation will not give erroneous pressure indications during the fill. Therefore, the best location to install the fill connection is close to the expansion tank. An air vent should be installed close by to help eliminate air that enters during the fill procedure.

Ensure the following when filling the system:

1. Remove temporary bypass piping and cleaning/flushing equipment.
2. Check to make sure all drain plugs are installed.
3. Open the blow-down valve to flush the strainer.

Normally, a closed system needs to be filled only once. The actual filling process is generally a fairly simple procedure. All air should be purged or vented from the system. Thorough venting at the high points and circulation at room temperature for several hours is recommended.

NOTE: Local codes concerning backflow devices and other protection of the city water system should be consulted and followed to prevent contamination of the public water supply. This is especially important when antifreeze is used in the system.

Set Water Flow Rate — Once the system is cleaned, pressurized, and filled, the flow rate through the chiller must be established. On units with the hydronic package, this can best be done using the balancing valve.

In order to adjust the balancing valve, put a differential pressure gage across the pressure taps on the valve. Make sure that all system isolation and control valves are open. Use Tables 10-13 to determine gpm.

1. Measure the pressure drop across the balancing valve. If the pressure reading is in psig, multiply psig by 2.31 to convert to feet of water before using Tables 10-14.
2. Go to the row in the chart corresponding to the setting on the valve, interpolating if necessary.
3. The gpm corresponding to the pressure drop measured is the flow through the balancing valve.

NOTE: Carrier recommends a differential pressure gage when measuring pressures across the pumps or balancing valves. This provides for greater accuracy and reduces error build-up that often occurs when subtracting pressures made by different gages.

On primary/secondary systems, it is advisable to set the 30RAP balancing valve to maintain design flow plus 10% through the chiller.

A rough estimate of water flow can also be obtained from the pressure gages across the 30RAP heat exchanger. Figures 27-34 show the relationship between gpm and heat exchanger pressure drop. It should be noted that these curves are for “clean” heat exchangers; they do not apply to heat exchangers with fouling. To read the chart, subtract the readings of the two pressure gages on the hydronic kit. This number is the pressure drop across the heat exchanger. Adjust the factory-installed balancing valve or external balancing valve (units without hydronic package) until the correct pressure drop is obtained for the required gpm. Total unit pressure drop is found in Appendix A.

Water Treatment — Fill the fluid loop with water (or suitable inhibited antifreeze solution) and a corrosion-resistant inhibitor suitable for the water of the area. Consult the local water treatment specialist for characteristics of system water and a recommended inhibitor for the cooler fluid loop.

Untreated or improperly treated water may result in corrosion, scaling, erosion, or algae. The services of a qualified water treatment specialist should be obtained to develop and monitor a treatment program.

CAUTION

Water must be within design flow limits, clean, and treated to ensure proper chiller performance and reduce the potential of tube damage due to corrosion, scaling, erosion, and algae. Carrier assumes no responsibility for chiller damage resulting from untreated or improperly treated water.

Table 10 — Balancing Valve Readings — 30RAP011-030

2.0 in. SETTING	VALVE COEFFICIENT (C _v)	WATER PRESSURE DROP (ft)									
		GPM									
		5	10	15	20	25	30	35	40	45	50
0.5	8.3	0.8	3.4	7.5	13.4	21.0	30.2	41.1	53.7	67.9	83.8
1.0	10.2	0.6	2.2	5.0	8.9	13.9	20.0	27.2	35.5	45.0	55.5
1.5	13.0	0.3	1.4	3.1	5.5	8.5	12.3	16.7	21.9	27.7	34.2
2.0	16.9	0.2	0.8	1.8	3.2	5.1	7.3	9.9	12.9	16.4	20.2
2.5	20.5	0.1	0.5	1.2	2.2	3.4	4.9	6.7	8.8	11.1	13.7
3.0	25.9	0.1	0.3	0.8	1.4	2.2	3.1	4.2	5.5	7.0	8.6
3.5	29.0	0.1	0.3	0.6	1.1	1.7	2.5	3.4	4.4	5.6	6.9
4.0	35.8	0.0	0.2	0.4	0.7	1.1	1.6	2.2	2.9	3.6	4.5
5.0	37.0	0.0	0.2	0.4	0.7	1.1	1.5	2.1	2.7	3.4	4.2

2.0 in. SETTING	VALVE COEFFICIENT (C _v)	WATER PRESSURE DROP (ft)									
		GPM									
		55	60	65	70	75	80	85	90	95	100
0.5	8.3	101.4	120.7	141.7	164.3	188.6	214.6	242.3	271.6	302.6	335.3
1.0	10.2	67.2	79.9	93.8	108.8	124.9	142.1	160.4	179.8	200.4	222.0
1.5	13.0	41.3	49.2	57.8	67.0	76.9	87.5	98.8	110.7	123.4	136.7
2.0	16.9	24.5	29.1	34.2	39.6	45.5	51.8	58.4	65.5	73.0	80.9
2.5	20.5	16.6	19.8	23.2	26.9	30.9	35.2	39.7	44.5	49.6	55.0
3.0	25.9	10.4	12.4	14.5	16.9	19.4	22.0	24.9	27.9	31.1	34.4
3.5	29.0	8.3	9.9	11.6	13.5	15.5	17.6	19.8	22.2	24.8	27.5
4.0	35.8	5.5	6.5	7.6	8.8	10.1	11.5	13.0	14.6	16.3	18.0
5.0	37.0	5.1	6.1	7.1	8.3	9.5	10.8	12.2	13.7	15.2	16.9

NOTE: See Table 14 for Glycol Correction Factors.

Table 11 — Balancing Valve Readings — 30RAP035-060

2.5 in. SETTING	VALVE COEFFICIENT (C _v)	WATER PRESSURE DROP (ft)										
		GPM										
		40	45	50	55	60	65	70	75	80	85	90
1.0	15.6	15.2	19.2	23.7	28.7	34.2	40.1	46.5	53.4	60.7	68.6	76.9
2.0	21.1	8.3	10.5	13.0	15.7	18.7	21.9	25.4	29.2	33.2	37.5	42.0
3.0	24.5	6.2	7.8	9.6	11.6	13.9	16.3	18.9	21.6	24.6	27.8	31.2
4.0	38.0	2.6	3.2	4.0	4.8	5.8	6.8	7.8	9.0	10.2	11.6	13.0
4.5	52.0	1.4	1.7	2.1	2.6	3.1	3.6	4.2	4.8	5.5	6.2	6.9
5.0	69.0	0.8	1.0	1.2	1.5	1.7	2.0	2.4	2.7	3.1	3.5	3.9

2.5 in. SETTING	VALVE COEFFICIENT (C _v)	WATER PRESSURE DROP (ft)										
		GPM										
		95	100	105	110	115	120	125	130	135	140	145
1.0	15.6	85.7	94.9	104.7	114.9	125.5	136.7	148.3	160.4	173.0	186.0	199.6
2.0	21.1	46.8	51.9	57.2	62.8	68.6	74.7	81.1	87.7	94.6	101.7	109.1
3.0	24.5	34.7	38.5	42.4	46.6	50.9	55.4	60.1	65.0	70.1	75.4	80.9
4.0	38.0	14.4	16.0	17.6	19.4	21.2	23.0	25.0	27.0	29.2	31.4	33.6
4.5	52.0	7.7	8.5	9.4	10.3	11.3	12.3	13.3	14.4	15.6	16.7	18.0
5.0	69.0	4.4	4.9	5.3	5.9	6.4	7.0	7.6	8.2	8.8	9.5	10.2

2.5 in. SETTING	VALVE COEFFICIENT (C _v)	WATER PRESSURE DROP (ft)										
		GPM										
		150	155	160	165	170	175	180	185	190	195	200
1.0	15.6	213.6	228.0	243.0	258.4	274.3	290.7	307.5	324.9	342.7	360.9	379.7
2.0	21.1	116.7	124.7	132.8	141.3	149.9	158.9	168.1	177.6	187.3	197.3	207.5
3.0	24.5	86.6	92.5	98.5	104.8	111.2	117.9	124.7	131.7	138.9	146.3	153.9
4.0	38.0	36.0	38.4	41.0	43.6	46.2	49.0	51.8	54.8	57.8	60.8	64.0
4.5	52.0	19.2	20.5	21.9	23.3	24.7	26.2	27.7	29.2	30.8	32.5	34.2
5.0	69.0	10.9	11.7	12.4	13.2	14.0	14.9	15.7	16.6	17.5	18.4	19.4

NOTE: See Table 14 for Glycol Correction Factors.

Table 12 — Balancing Valve Readings — 30RAP070-090

3.0 in. STRAIGHT SETTING	VALVE COEFFICIENT (C _v)	WATER PRESSURE DROP (ft)												
		GPM												
		70	80	90	100	110	120	130	140	150	160	170	180	190
1.0	20.0	28.3	37.0	46.8	57.8	69.9	83.2	97.6	113.2	129.9	147.8	166.9	187.1	208.5
1.5	22.9	21.6	28.2	35.7	44.0	53.3	63.4	74.4	86.3	99.1	112.8	127.3	142.7	159.0
2.0	25.6	17.3	22.6	28.6	35.2	42.6	50.8	59.6	69.1	79.3	90.2	101.9	114.2	127.2
2.5	27.0	15.5	20.3	25.7	31.7	38.3	45.6	53.6	62.1	71.3	81.1	91.6	102.7	114.4
3.0	30.0	12.6	16.4	20.8	25.7	31.1	37.0	43.4	50.3	57.8	65.7	74.2	83.2	92.7
3.5	36.5	8.5	11.1	14.0	17.3	21.0	25.0	29.3	34.0	39.0	44.4	50.1	56.2	62.6
4.0	56.0	3.6	4.7	6.0	7.4	8.9	10.6	12.4	14.4	16.6	18.9	21.3	23.9	26.6
4.5	76.0	2.0	2.6	3.2	4.0	4.8	5.8	6.8	7.8	9.0	10.2	11.6	13.0	14.4
5.0	94.5	1.3	1.7	2.1	2.6	3.1	3.7	4.4	5.1	5.8	6.6	7.5	8.4	9.3

3.0 in. STRAIGHT SETTING	VALVE COEFFICIENT (C _v)	WATER PRESSURE DROP (ft)												
		GPM												
		200	210	220	230	240	250	260	270	280	290	300	310	320
1.0	20.0	231.0	254.7	279.5	305.5	332.6	360.9	390.4	421.0	452.8	485.7	519.8	555.0	591.4
1.5	22.9	176.2	194.3	213.2	233.0	253.7	275.3	297.8	321.1	345.3	370.5	396.4	423.3	451.1
2.0	25.6	141.0	155.4	170.6	186.5	203.0	220.3	238.3	257.0	276.3	296.4	317.2	338.7	360.9
2.5	27.0	126.7	139.7	153.4	167.6	182.5	198.0	214.2	231.0	248.4	266.5	285.2	304.5	324.5
3.0	30.0	102.7	113.2	124.2	135.8	147.8	160.4	173.5	187.1	201.2	215.9	231.0	246.7	262.8
3.5	36.5	69.4	76.5	83.9	91.7	99.9	108.4	117.2	126.4	135.9	145.8	156.1	166.6	177.6
4.0	56.0	29.5	32.5	35.7	39.0	42.4	46.0	49.8	53.7	57.8	61.9	66.3	70.8	75.4
4.5	76.0	16.0	17.6	19.4	21.2	23.0	25.0	27.0	29.2	31.4	33.6	36.0	38.4	41.0
5.0	94.5	10.3	11.4	12.5	13.7	14.9	16.2	17.5	18.9	20.3	21.8	23.3	24.9	26.5

3.0 in. STRAIGHT SETTING	VALVE COEFFICIENT (C _v)	WATER PRESSURE DROP (ft)												
		GPM												
		330	340	350	360	370	380	390	400	410	420	430	440	450
1.0	20.0	628.9	667.6	707.4	748.4	790.6	833.9	878.4	924.0	970.8	1018.7	1067.8	1118.0	1169.4
1.5	22.9	479.7	509.2	539.6	570.9	603.0	636.1	670.0	704.8	740.5	777.0	814.5	852.8	892.0
2.0	25.6	383.8	407.5	431.8	456.8	482.5	509.0	536.1	564.0	592.5	621.8	651.7	682.4	713.8
2.5	27.0	345.1	366.3	388.2	410.7	433.8	457.6	482.0	507.0	532.7	559.0	585.9	613.5	641.7
3.0	30.0	279.5	296.7	314.4	332.6	351.4	370.6	390.4	410.7	431.5	452.8	474.6	496.9	519.8
3.5	36.5	188.8	200.4	212.4	224.7	237.4	250.4	263.7	277.4	291.5	305.9	320.6	335.7	351.1
4.0	56.0	80.2	85.2	90.2	95.5	100.8	106.4	112.0	117.9	123.8	129.9	136.2	142.6	149.2
4.5	76.0	43.6	46.2	49.0	51.8	54.8	57.8	60.8	64.0	67.2	70.5	73.9	77.4	81.0
5.0	94.5	28.2	29.9	31.7	33.5	35.4	37.4	39.3	41.4	43.5	45.6	47.8	50.1	52.4

NOTE: See Table 14 for Glycol Correction Factors.

Table 13 — Balancing Valve Readings — 30RAP100-150

4.0 in. STRAIGHT SETTING	VALVE COEFFICIENT (Cv)	WATER PRESSURE DROP (ft)													
		GPM													
		80	90	100	110	120	130	140	150	160	170	180	190	200	
1.0	21.5	32.0	40.5	50.0	60.5	72.0	84.5	97.9	112.4	127.9	144.4	161.9	180.4	199.9	
1.5	25.0	23.7	29.9	37.0	44.7	53.2	62.5	72.4	83.2	94.6	106.8	119.8	133.4	147.8	
2.0	27.2	20.0	25.3	31.2	37.8	45.0	52.8	61.2	70.3	79.9	90.2	101.2	112.7	124.9	
2.5	43.0	8.0	10.1	12.5	15.1	18.0	21.1	24.5	28.1	32.0	36.1	40.5	45.1	50.0	
3.0	68.0	3.2	4.0	5.0	6.0	7.2	8.4	9.8	11.2	12.8	14.4	16.2	18.0	20.0	
3.5	100.0	1.5	1.9	2.3	2.8	3.3	3.9	4.5	5.2	5.9	6.7	7.5	8.3	9.2	
4.0	129.0	0.9	1.1	1.4	1.7	2.0	2.3	2.7	3.1	3.6	4.0	4.5	5.0	5.6	
4.5	162.0	0.6	0.7	0.9	1.1	1.3	1.5	1.7	2.0	2.3	2.5	2.9	3.2	3.5	
5.0	190.0	0.4	0.5	0.6	0.8	0.9	1.1	1.3	1.4	1.6	1.8	2.1	2.3	2.6	
5.5	216.0	0.3	0.4	0.5	0.6	0.7	0.8	1.0	1.1	1.3	1.4	1.6	1.8	2.0	
6.0	249.0	0.2	0.3	0.4	0.5	0.5	0.6	0.7	0.8	1.0	1.1	1.2	1.3	1.5	

4.0 in. STRAIGHT SETTING	VALVE COEFFICIENT (Cv)	WATER PRESSURE DROP (ft)													
		GPM													
		210	220	230	240	250	260	270	280	290	300	310	320	330	
1.0	21.5	220.4	241.9	264.4	287.8	312.3	337.8	364.3	391.8	420.3	449.8	480.2	511.7	544.2	
1.5	25.0	163.0	178.9	195.5	212.9	231.0	249.8	269.4	289.8	310.8	332.6	355.2	378.5	402.5	
2.0	27.2	137.7	151.1	165.2	179.8	195.1	211.1	227.6	244.8	262.6	281.0	300.1	319.7	340.0	
2.5	43.0	55.1	60.5	66.1	72.0	78.1	84.5	91.1	97.9	105.1	112.4	120.1	127.9	136.1	
3.0	68.0	22.0	24.2	26.4	28.8	31.2	33.8	36.4	39.2	42.0	45.0	48.0	51.2	54.4	
3.5	100.0	10.2	11.2	12.2	13.3	14.4	15.6	16.8	18.1	19.4	20.8	22.2	23.7	25.2	
4.0	129.0	6.1	6.7	7.3	8.0	8.7	9.4	10.1	10.9	11.7	12.5	13.3	14.2	15.1	
4.5	162.0	3.9	4.3	4.7	5.1	5.5	6.0	6.4	6.9	7.4	7.9	8.5	9.0	9.6	
5.0	190.0	2.8	3.1	3.4	3.7	4.0	4.3	4.7	5.0	5.4	5.8	6.1	6.6	7.0	
5.5	216.0	2.2	2.4	2.6	2.9	3.1	3.3	3.6	3.9	4.2	4.5	4.8	5.1	5.4	
6.0	249.0	1.6	1.8	2.0	2.1	2.3	2.5	2.7	2.9	3.1	3.4	3.6	3.8	4.1	

4.0 in. STRAIGHT SETTING	VALVE COEFFICIENT (Cv)	WATER PRESSURE DROP (ft)													
		GPM													
		340	350	360	370	380	390	400	410	420	430	440	450		
1.0	21.5	577.7	612.2	647.6	684.1	721.6	760.1	799.6	840.0	881.5	924.0	967.5	1012.0		
1.5	25.0	427.3	452.8	479.0	506.0	533.7	562.2	591.4	621.3	652.0	683.4	715.5	748.4		
2.0	27.2	360.9	382.5	404.6	427.4	450.9	474.9	499.6	524.9	550.8	577.3	604.5	632.3		
2.5	43.0	144.4	153.0	161.9	171.0	180.4	190.0	199.9	210.0	220.4	231.0	241.9	253.0		
3.0	68.0	57.8	61.2	64.7	68.4	72.1	76.0	79.9	84.0	88.1	92.4	96.7	101.2		
3.5	100.0	26.7	28.3	29.9	31.6	33.4	35.1	37.0	38.8	40.7	42.7	44.7	46.8		
4.0	129.0	16.0	17.0	18.0	19.0	20.0	21.1	22.2	23.3	24.5	25.7	26.9	28.1		
4.5	162.0	10.2	10.8	11.4	12.0	12.7	13.4	14.1	14.8	15.5	16.3	17.0	17.8		
5.0	190.0	7.4	7.8	8.3	8.8	9.2	9.7	10.2	10.8	11.3	11.8	12.4	13.0		
5.5	216.0	5.7	6.1	6.4	6.8	7.1	7.5	7.9	8.3	8.7	9.2	9.6	10.0		
6.0	249.0	4.3	4.6	4.8	5.1	5.4	5.7	6.0	6.3	6.6	6.9	7.2	7.5		

NOTE: See Table 14 for Glycol Correction Factors.

Table 14 — Glycol Correction Factors

CONCENTRATION	GLYCOL CORRECTION FACTOR			
	Ethylene		Propylene	
	Water Temp — °F (°C)			
	40 (4.5)	70 (21)	40 (4.5)	70 (21)
0	1.00	1.00	1.00	1.00
10	0.99	0.99	0.99	0.99
20	0.99	0.99	0.99	0.99
30	0.98	0.98	0.99	0.99
40	0.97	0.97	0.98	0.98
50	0.96	0.96	0.97	0.98

Glycol Corrections:

$$\text{GPM [actual]} = \text{GPM [tested]} \times \text{Correction Factor}$$

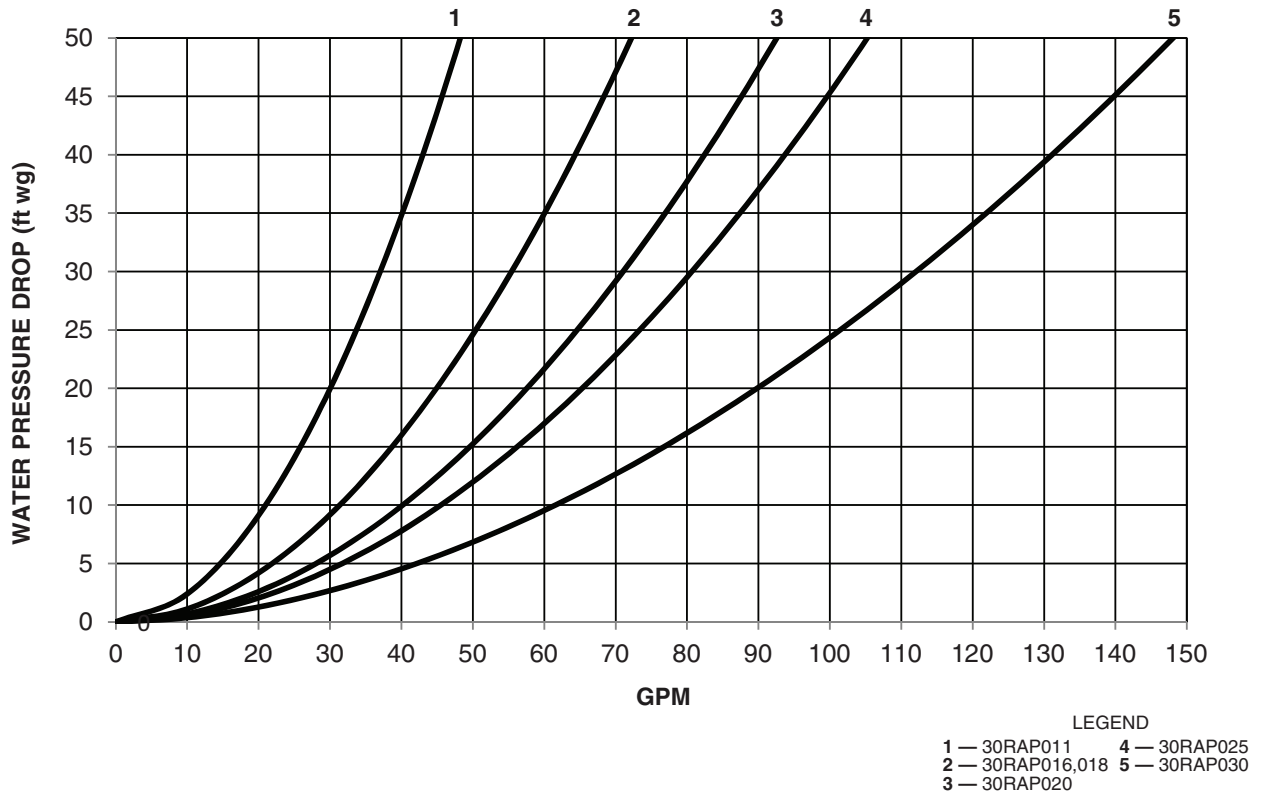

Fig. 27 — Heat Exchanger Pressure Drop (Water Only) — 30RAP011-030 (English)

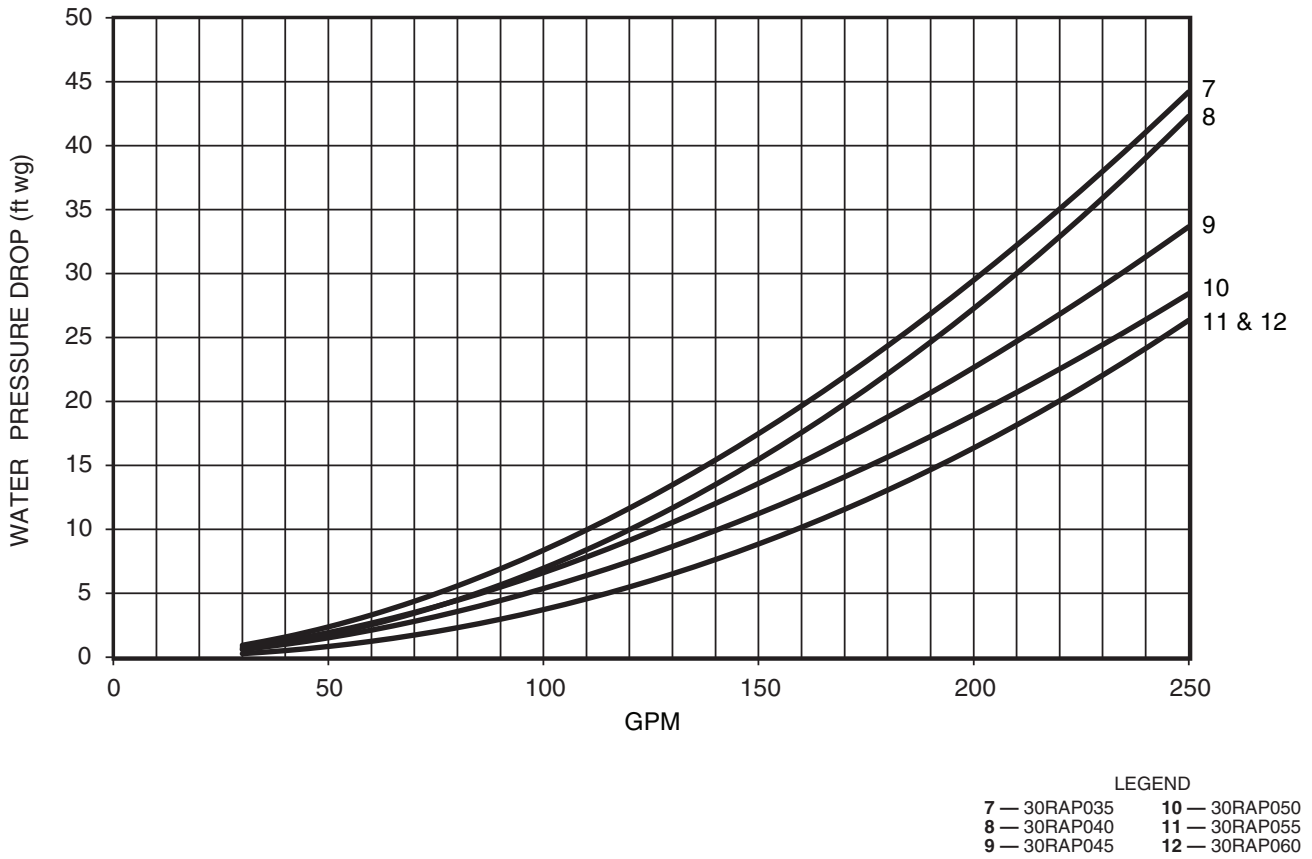

Fig. 28 — Heat Exchanger Pressure Drop (Water Only) — 30RAP035-060 (English)

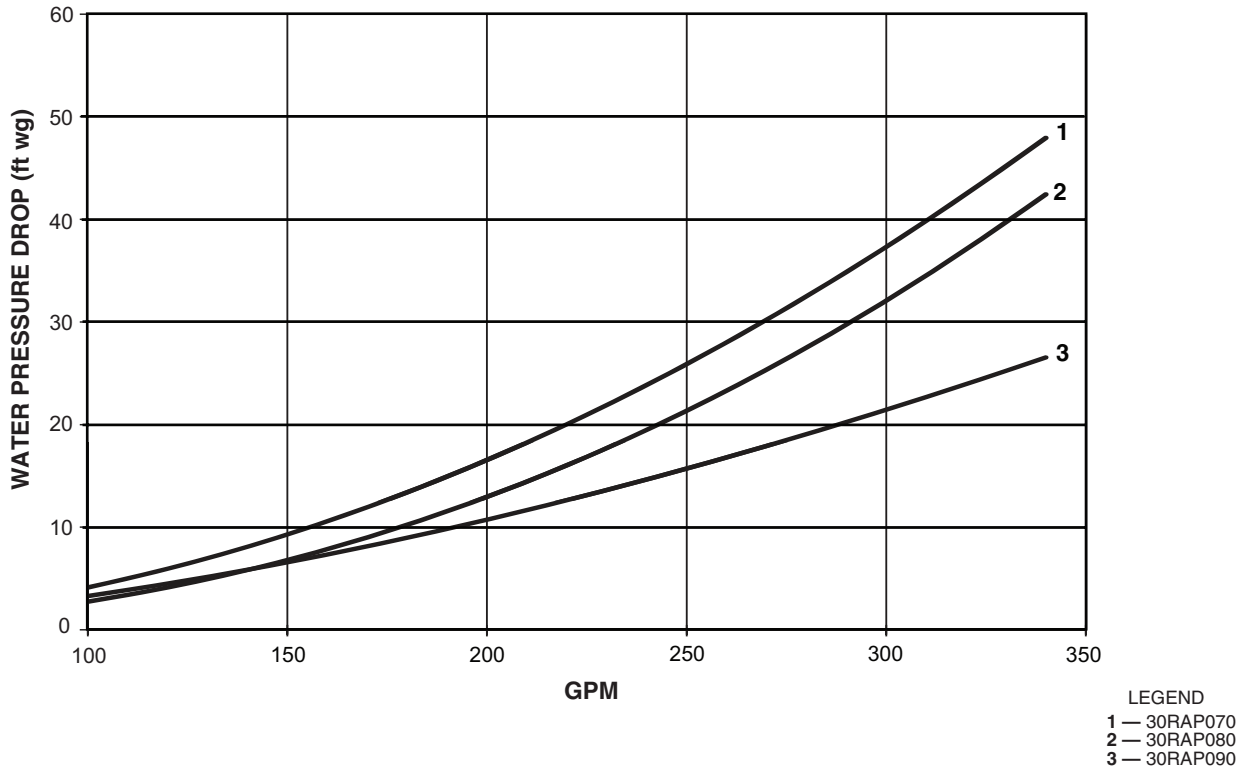

Fig. 29 — Heat Exchanger Pressure Drop (Water Only) — 30RAP070-090 (English)

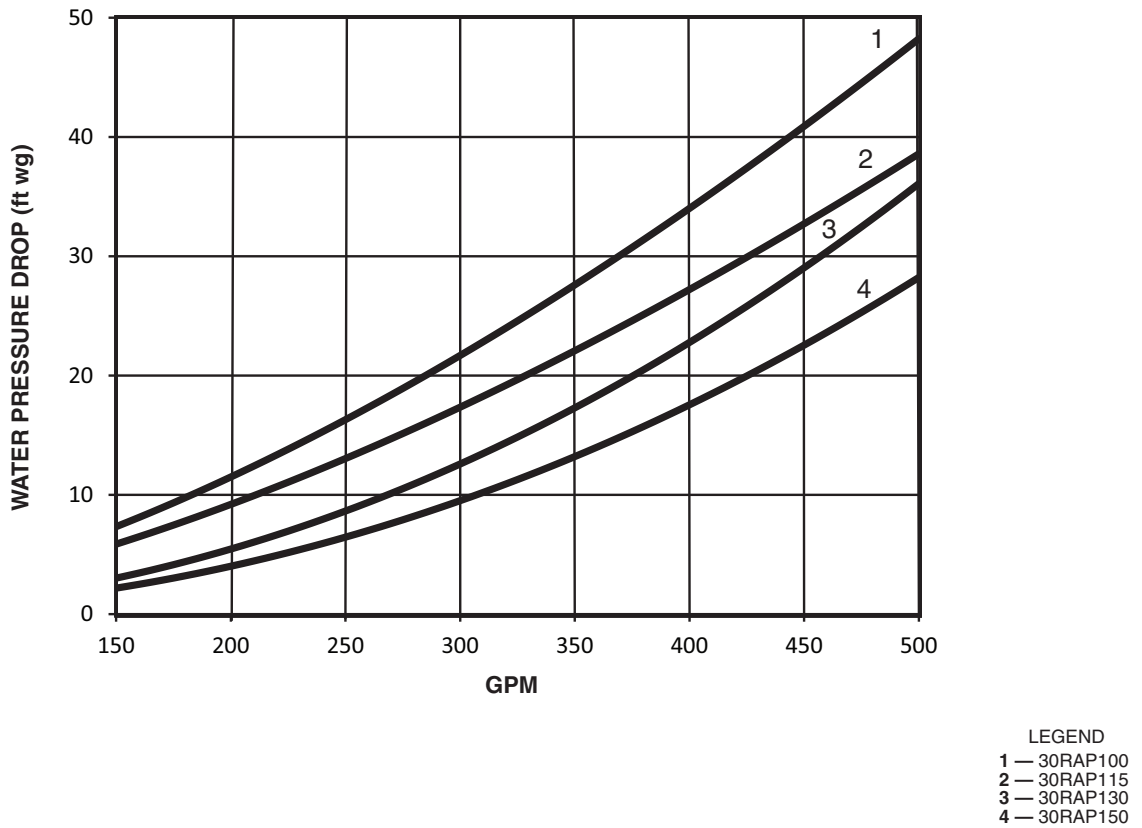
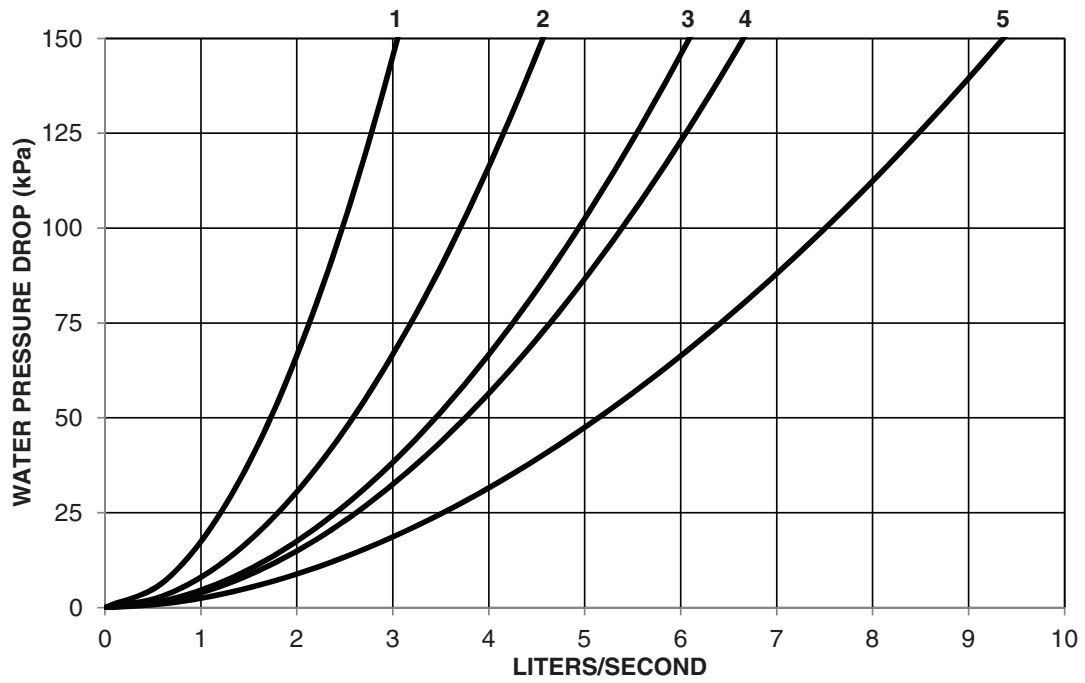
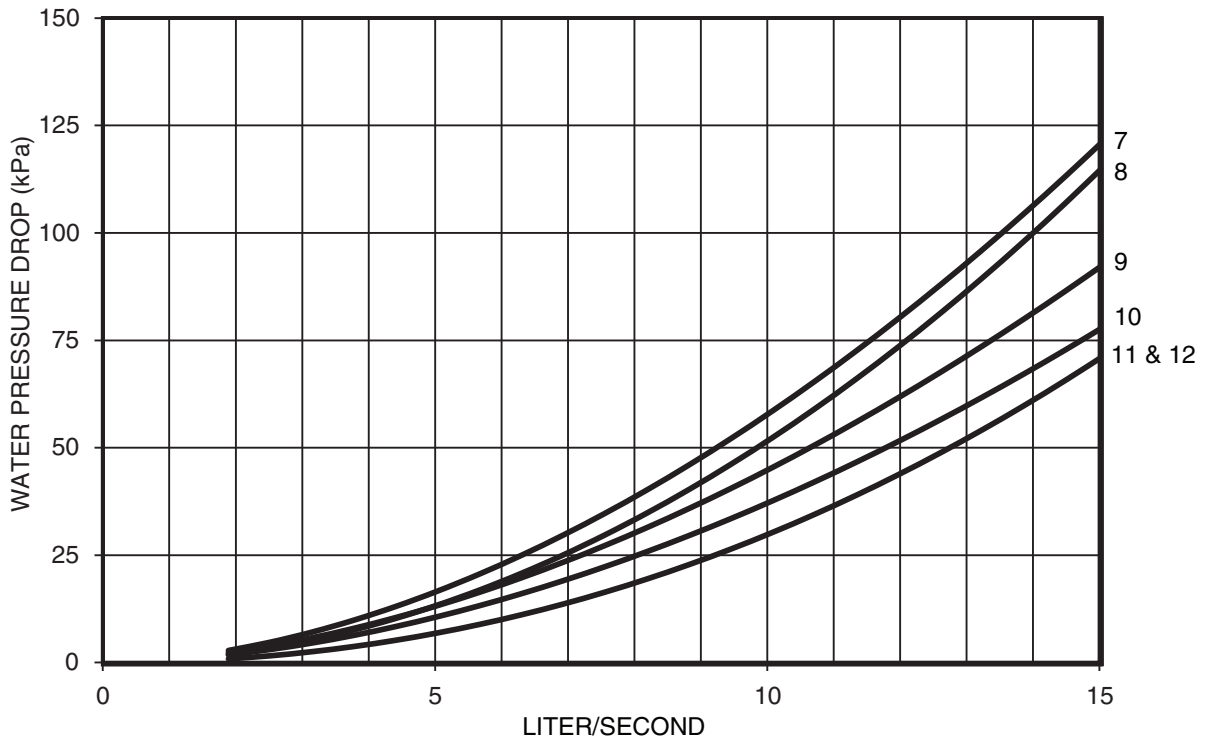

Fig. 30 — Heat Exchanger Pressure Drop (Water Only) — 30RAP100-150 (English)



LEGEND
 1 — 30RAP011 4 — 30RAP025
 2 — 30RAP016,018 5 — 30RAP030
 3 — 30RAP020

Fig. 31 — Heat Exchanger Pressure Drop (Water Only) — 30RAP011-030 (SI)



LEGEND
 7 — 30RAP035 10 — 30RAP050
 8 — 30RAP040 11 — 30RAP055
 9 — 30RAP045 12 — 30RAP060

Fig. 32 — Heat Exchanger Pressure Drop (Water Only) — 30RAP035-060 (SI)

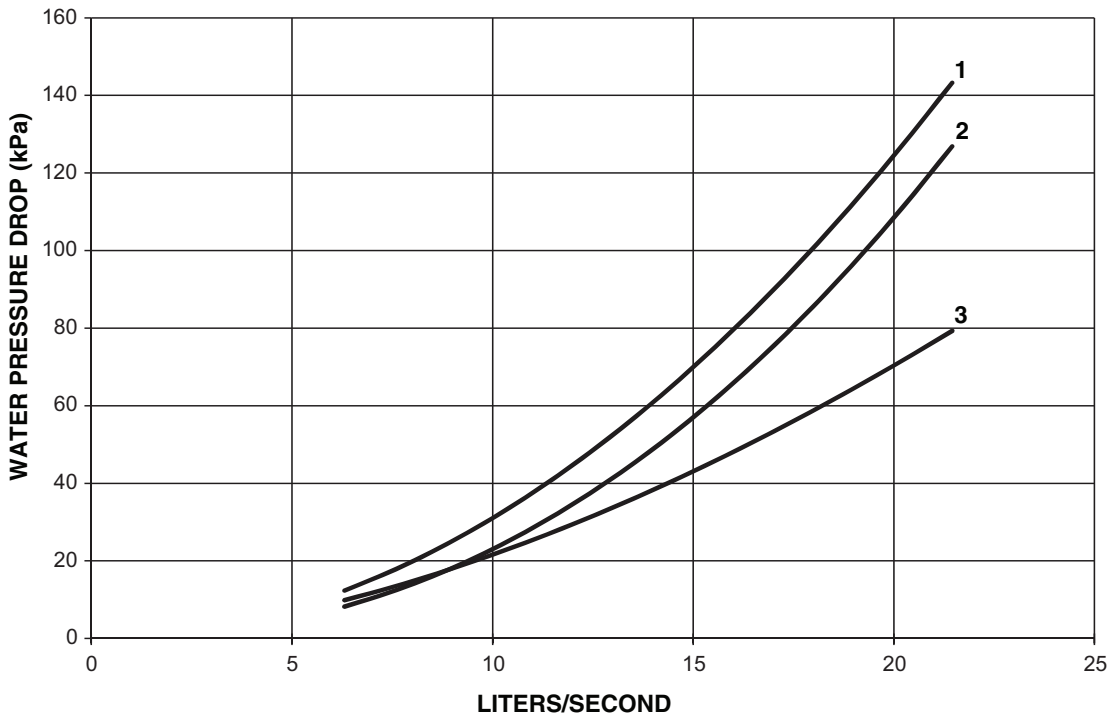

LEGEND
 1 — 30RAP070
 2 — 30RAP080
 3 — 30RAP090

Fig. 33 — Heat Exchanger Pressure Drop (Water Only) — 30RAP070-090 (SI)

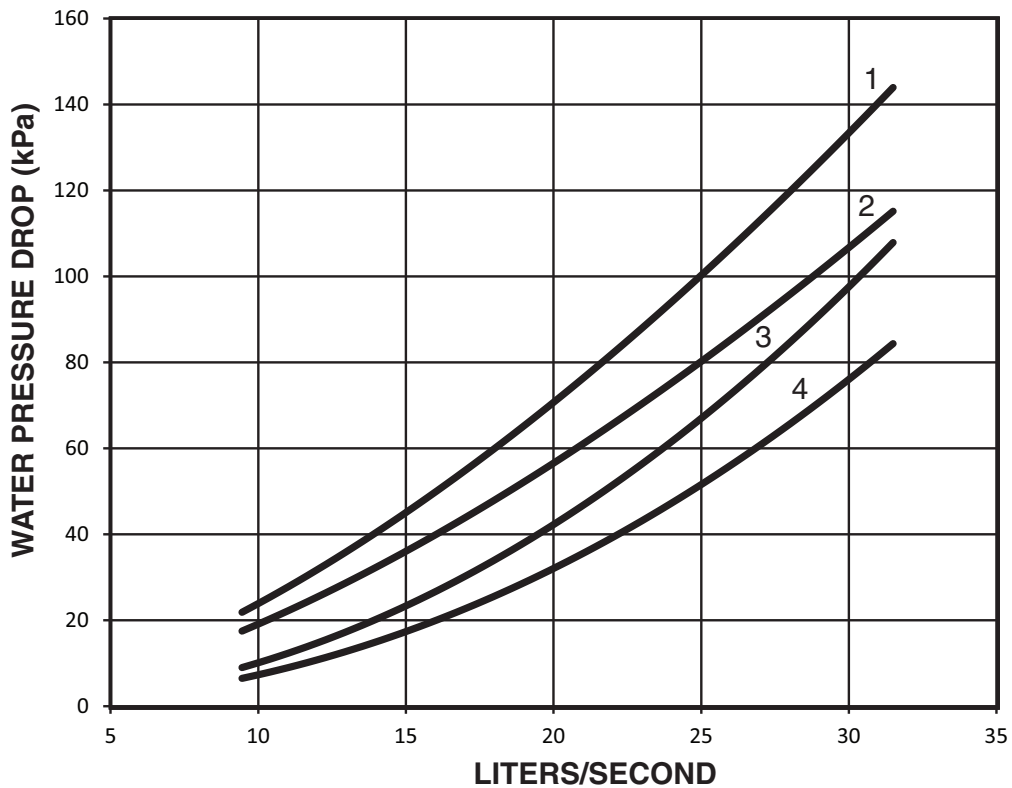

LEGEND
 1 — 30RAP100
 2 — 30RAP115
 3 — 30RAP130
 4 — 30RAP150

Fig. 34 — Heat Exchanger Pressure Drop (Water Only) — 30RAP100-150 (SI)

Minimum Loop Volume — The minimum volume of fluid required to be in circulation is a function of the number of compressors in the chiller as well as the type of application. The minimum fluid in circulation must equal or exceed the values in Table 15.

To achieve this fluid volume, it is often necessary to install a tank in the loop. The tank should be baffled to ensure there is no stratification and that water (or suitable inhibited antifreeze solution) entering the tank is adequately mixed with liquid in the tank. See Fig. 35.

Table 15 — Minimum Fluid Volume In Circulation

30RAP UNIT SIZE	NORMAL AIR CONDITIONING APPLICATION gal./ton (L per kW)			PROCESS COOLING OR LOW AMBIENT OPERATION APPLICATION gal./ton (L per kW)		
	Std Unit	HGBP	Digital	Std Unit	HGBP	Digital
011-016	12 (13.0)	N/A	3 (3.3)	12 (13.0)	N/A	6 (6.5)
018-030	6 (6.5)	4 (4.3)	3 (3.3)	10 (10.8)	10 (10.8)	6 (6.5)
035-150	3 (3.3)	3 (3.3)	3 (3.3)	6 (6.5)	6 (6.5)	6 (6.5)

LEGEND

HGBP — Hot Gas Bypass

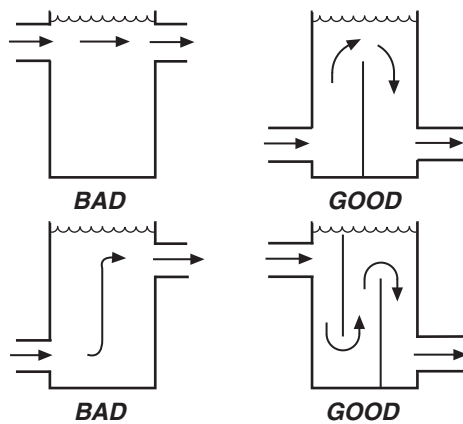

Fig. 35 — Tank Baffling

The piping between the chiller and the accessory tank can be done to allow the tank to be on the return side of the chiller (tank piped to chiller inlet) or the supply side of the chiller (tank piped to chiller outlet). For standard compressors, it is recommended that the tank be piped to the return side of the chiller to buffer any changes in load to allow more stable chiller operation. For digital compressor applications, it is recommended that the tank be piped to the supply side of the chiller to provide a more stable supply temperature.

A properly baffled storage tank is available from the factory as an accessory for sizes 011-060 only. These tanks are designed to physically fit beneath the corresponding 30RAP unit, taking up the same footprint.

- 30RAP011, 016 83 gallons (314 liters)
- 30RAP018-030 119 gallons (450 liters)
- 30RAP035-060 241 gallons (912 liters)

Storage tank weight (water weight included) is as follows:

- 30RAP011, 016 1673 lb (759 kg)
- 30RAP018-030 2193 lb (995 kg)
- 30RAP035-060 4361 lb (1978 kg)

Maximum Loop Volume (Units with Hydronic Package) — Since the minimum size of the expansion tank is dependent upon loop volume, units with the integrated hydronic kit must not exceed the maximum loop volume limits (see Table 16).

The limits are dependent on the maximum and minimum temperatures of the water, the maximum and minimum pressures seen by the expansion tank, and the heat transfer fluid. Expansion tank and maximum loop volume data is as follows:

	30RAP011-030	30RAP035-060
Volume gal. (L)	5.0 (18.9)	10.0 (37.9)
Acceptance Volume gal. (L)	2.9 (11.0)	5.5 (20.8)

Table 16 — Maximum Loop Volume

CONCENTRATION	30RAP011-030		30RAP035-060	
	GAL.	L	GAL.	L
PURE WATER	230	871	738	2793
10% EG	132	500	425	1609
20% EG	123	466	394	1491
30% EG	114	431	366	1385
40% EG	107	405	342	1294
10% PG	124	469	399	1510
20% PG	106	401	339	1283
30% PG	93	352	298	1128
40% PG	83	314	267	1011

LEGEND

- EG — Ethylene Glycol
- PG — Propylene Glycol

NOTE: Maximum loop volume is based on typical system of 12 psig (83 kPa) and 30 psig (207 kPa) of min/max pressures, and 38°F (3.3°C) and 100°F (37.8°C) min/max water temperature. If the volume in the system is greater than the limits listed, then extra expansion tank volume must be added to the system.

Pump Modification/Trimming (Units with Factory-Installed Hydronic Package) — Since the pumps are constant speed, the only way to obtain greater flow with a given pump/impeller is to decrease system head. This will allow the pump to “ride” its curve to the right, resulting in increased flow. If greater flow is necessary, look at opening the balance valve. Also, verify that the strainer is clean, and that no unnecessary system resistance is present, such as partially closed isolation valves.

Increasing system resistance by closing the balancing valve will force the pump to “ride” its curve to the left, resulting in less flow. Although this does reduce power consumption slightly, it may not be the desirable method of reducing the flow, especially if a rather large reduction is needed.

The other method for reducing flow on a constant speed pump is impeller trimming. The impellers in the pumps provided in the 30RAP hydronic kit are easily removable for this purpose. Refer to the pump literature packet supplied with the hydronic package information on Seal Replacement in the Service Section, and follow its instructions for impeller removal. Trimming should only be done by a qualified machine shop that has experience in this operation. Contact your local Carrier representative for a recommended machine shop. After trimming, the impeller MUST be balanced. Failure to balance trimmed impellers can result in excessive vibration, noise, and premature bearing failure. Impeller trimming has the added benefit of maximum bhp savings.

Power savings may pay for the trimming cost very quickly. The 30RAP pump option may be applied with a field-supplied VFD. When applied with a VFD, the maximum length of wiring between the drive and the pump motor is 50 ft (15.2 m). The maximum allowable carrier frequency of the inverter is 12 kHz, with 3 kHz recommended.

PUMP VFD — Pumps may be ordered with a variable frequency drive (VFD) for speed control (sizes 070-150 only). Armstrong pump VFD password is 00002323 to allow access to parameters.

SENSORLESS CONTROL (CLOSED LOOP) — ACTIVE SETUP 1 — The VFD provided with the pump from the factory is configured for sensorless control. Default set points are entered for the unit according to nominal tonnage of the unit. Table 17 shows the settings from the factory. For details on operating the drive display, see the pump installation and operation manual, and for more detailed information on the drive, see IVS 102 Operating Instructions. These manuals are supplied in the control box of the chiller.

The following set points should be verified or modified for the actual installation.

- Parameter 20-21 Setpoint, Hd, Ft-Wc
- Parameter 22-89 Design Flow Setpoint, GPM
- Parameter 22-87 Pressure at no-flow speed, Hmin, Ft-Wc (40% of Hd)

When changing set points, assure values are within the pump curve for the pump provided with the unit.

Minimum speed for the pump is set at 50 Hz, Parameter 4-12. This may be changed as long as the corresponding flow rate meets the minimum flow requirement for the chiller.

REMOTE SENSOR (CLOSED LOOP) — ACTIVE SETUP 2 — The drive may be set up to use a remote sensor instead of sensorless pump control. For a remote sensor

control change Active Setup on the drive from 1 to 2, Parameter 0-10. The drive will read a 0-10 vdc or a 0/4-20 mA signal from the sensor. Switch S2-01 must be set to Off (default setting) for 0-10 vdc or On for 0/4-20 mA. The switch is located behind the display. The cover must be removed and the display will snap off to access this switch.

The set point is defined by Parameter 20-21, Setpoint 1. This is a percentage of the maximum signal from the sensor. The default is 80%.

REMOTE CONTROLLER (OPEN LOOP) — ACTIVE SETUP 3 — Drive may be controlled by external sources. For a remote control of the drive change Active Setup on the drive to 3, Parameter 0-10, and change Parameter 1-00 to 0 (open loop). An input signal can be used to control the drive speed. Input signal may be 0-10 vdc or 0/4-20 mA. The setup is the same as a remote sensor.

A BACnet¹ card is also included with the drive. For BACnet, use Setup 3. The communication settings are in section 8 of the drive parameters. See drive manual for details.

1. BACnet is a registered trademark of ASHRAE (American Society of Heating, Refrigerating, and Air-Conditioning Engineers).

Table 17 — Default Settings for Sensorless Control — Setup 1

SINGLE PUMP																			
Unit Size (tons)				070				080, 090, 100				115, 130				150			
Hydronic System Option				F	G	D	F	G	H	D	F	G	H	D	F	G	H		
Pump Number				4360 3D		4380 3x3x5		4360 3D		4380 3x3x6				4380 4x4x8		4380 4x4x6			
HP				7.5	10	7.5		15		5	7.5	10	15	5	7.5	10	15		
Impeller Dia (in.)				5.25	5.75	5.25		6.5		4.5	5.0	5.4	6.1	6.5	7.4	4.6	5.2		
Param.	Desc.																		
20-21	Setpoint 1	Hd	ft wc	55	95	50	120	35	45	80	115	25	50	70	95				
22-89	Flow at Design Point		gpm	170				200				300				340			
22-87	Press at No Flow Speed	40%Hd	ft wc	22	38	20	48	14	18	32	46	10	20	28	38				

DUAL PUMP																					
Unit Size (tons)				070				080, 090, 100				115, 130				150					
Hydronic System Option				J	K	L	M	K	L	M	N	K	L	M	N	L	M	N			
Pump Number				4382 4x4x8		4382 4x4x6		4382 3x3x6		4382 4x4x6				4382 4x4x6				4382 4x4x6			
HP				3	5	7.5	10	5	7.5	10	15	5	7.5	10	15	7.5	10	15			
Impeller Dia (in.)				6.5	4.5	5.25	5.9	4.5	5.0	5.4	6.0	4.5	5.0	5.4	6.0	5.0	5.4	6.0			
Param.	Desc.																				
20-21	Setpoint 1	Hd	ft wc	30	45	55	95	40	50	90	120	35	45	80	115	50	70	95			
22-89	Flow at Design Point		gpm	170				200				300				340					
22-87	Press at No Flow Speed	40%Hd	ft wc	12	18	22	38	16	20	36	48	14	18	32	46	14	18	32			

PREPARATION FOR YEAR-ROUND OPERATION — If the unit is in operation year-round, add sufficient suitable inhibited antifreeze solution such as propylene or ethylene glycol to chilled water to prevent freezing under low-ambient temperature operating conditions. Consult a local water treatment specialist on characteristics of water and recommended inhibitor.

IMPORTANT: Glycol antifreeze solutions are highly recommended since heater tapes provide no protection in the event of a power failure.

Motormaster® low ambient temperature head pressure control is required if ambient temperatures are below 45°F (7°C) on size 018-030 units, and 32°F (0°C) on size 035-150 units. The Motormaster low ambient control option is not available on any unit which employs high-efficiency variable condenser fans (because units with such fans already have low ambient capability).

Accessory wind baffles are required with Motormaster head pressure control and high-efficiency variable condenser fans if the wind velocity is anticipated to be greater than 5 mph (8 km/h). Unit sizes 011-030 require one baffle and unit sizes 035-060 require two baffles. Unit sizes 070-150 require one baffle. See Table 18.

Table 18 — Wind Baffle Accessory Quantities

ACCESSORY PART NO. 30RA-900---	UNIT SIZE 30RAP					
	011, 016	018, 020	025, 030	035, 040	045-060	070-150
054	1	—	—	—	—	—
055	—	1	—	2	—	—
056	—	—	1	—	2	—
005	—	—	—	—	—	1

⚠ CAUTION

To avoid damage to refrigerant coils and electronic components, use extreme care when drilling screw holes and attaching fasteners.

FREEZE PROTECTION — The 30RAP units are provided with a water strainer and a flow switch to protect against freezing situations that occur from no water flow. While the flow switch (thermal dispersion) is helpful in preventing freezing during no-flow situations, it does not protect the chiller in case of power failure, or in other cases where water temperature falls below the freezing mark. Appropriate concentrations of inhibited glycol or other suitable inhibited antifreeze solution should be considered for chiller protection where ambient temperatures are expected to fall below 32°F (0.0°C). Consult local water treatment specialist on characteristics of the system water and add a recommended inhibitor to the chilled water.

⚠ CAUTION

Do not circulate water through unit without strainer in place. Failure to use the strainer represents abuse and may impair or otherwise negatively affect the Carrier product warranty.

1. If the pump will be subjected to freezing temperatures, steps must be taken to prevent freeze damage. If the pump will not be used during this time, it is recommended to drain the pump and hydronic package and back-flush these components with inhibited glycol. Otherwise, a glycol-water solution should be considered as the heat transfer fluid. Units have a drain mounted on the piping leaving the heat exchanger. Drains are located on the sheet metal base of all units.

NOTE: Do not use automobile antifreeze, or any other fluid that is not approved for heat exchanger duty. Use only appropriately inhibited glycols, concentrated to provide adequate protection for the temperature considered.

2. Use an electric tape heater for the internal piping if unit will be exposed to freezing temperature.
3. Ensure that power is available to the chiller at all times, even during the off-season, so that the pump and cooler heaters have power. Also make sure that the piping tape heaters have power.
4. On units with pump packages, a heater is supplied that will protect this section from freezing in outdoor-air temperatures down to -20°F (-29°C), except in case of a power failure.
5. Cooler heaters that will protect down to -20°F (-29°C) can be installed as a factory option. It should be noted that these heaters will not protect the cooler from freezing in the event of a power failure.

PREPARATION FOR WINTER SHUTDOWN — If the unit is not operational during the winter months, at the end of the cooling season complete the following steps.

⚠ CAUTION

Failure to remove power before draining heater-equipped coolers and hydronic packages can result in heater tape and insulation damage.

1. If the cooler/pump will not be drained, do not shut off power during off-season shutdown. If the cooler/pump is drained, open the circuit breaker for the heater or shut off power during off-season shutdown.
2. Drain water from the system.
3. Replace drain plug(s) and add sufficient inhibited glycol (or other suitable inhibited antifreeze) to cooler, pump, and piping to prevent freezing of residual water.
4. At the beginning of the next cooling season, refill cooler and add recommended inhibitor.

Step 5 — Make Electrical Connections

⚠ WARNING

Electrical shock can cause personal injury and death. Shut off all power to this equipment during installation. There may be more than one disconnect switch. Tag all disconnect locations to alert others not to restore power until work is completed.

POWER SUPPLY — Electrical characteristics of available power supply must agree with unit nameplate rating. Field wiring size must be within limits shown in Table 19. See Tables 20-34 for component electrical data.

IMPORTANT: Operating unit on improper supply voltage or with excessive phase imbalance constitutes abuse and may affect Carrier warranty.

POWER WIRING — All power wiring must comply with applicable local and national codes. Install field-supplied branch circuit fused disconnect per NEC (National Electric Code) of a type that can be locked OFF or ON. Disconnect must be within sight from and readily accessible from unit in compliance with NEC Article 440-14.

General Wiring Notes

1. The control circuit does NOT require a separate power source. Control circuit power is obtained by a step-down transformer from the main three-phase power supply. The

LVT (low voltage terminal) strip is provided for field-wired control devices.

2. Cooler and pump heaters (if factory installed) are wired in the control circuit so they are operable as long as the main power supply to the unit and heater safety device is ON. A factory-installed and set overload device protects them.
3. Power is at one end only.
4. All field power enters the unit through a hole located in the corner post of the unit or the bottom of the control box shelf. Refer to Fig. 36 for field wiring details.

Refer to Fig. 9-16 for exact location of field power entry. Be sure to seal entering power wire conduit per NEC requirements.

5. Maximum field wire sizes allowed by lugs on terminal block/non-fused disconnect are listed in Table 19.
6. Terminals for field power supply are suitable for copper conductors. Insulation must be rated 167°F (75°C) minimum.
7. Units with high short circuit ratings and terminal block option require that specific fuses be applied to achieve this rating. Refer to Table 19.

Table 19 — Field Wiring Sizes

CONNECTION TYPE	30RAP UNIT SIZES	MCA RANGE	WIRE SIZE RANGE	MAXIMUM NUMBER OF WIRES PER PHASE	HIGH SCCR FUSE TYPE
TERMINAL BLOCK	011-060	MCA up to 175	14 AWG to 2/0 AWG	1	J, T, RK1, RK5, G, CC
		MCA 175.1 to 335	6 AWG to 400 kcmil	1	J, T, RK1, RK5, G, CC
	070-150	MCA up to 420	2 AWG to 600 kcmil	1	J, T, RK1, RK5, G, CC
		MCA 420.1 to 760	6 AWG to 500 kcmil	2	J, T, RK1, RK5, G, CC
NON-FUSED DISCONNECT	All	MCA up to 100	14 AWG to 3/0 AWG	1	—
	All	MCA 100.1 to 250	6 AWG to 350 kcmil	1	—
	All	MCA 250.1 to 600	3/0 AWG to 500 kcmil	2	—

LEGEND

- AWG** — American Wire Gage
MCA — Minimum Circuit Amps
SCCR — Short Circuit Current Rating

NOTES:

1. Wiring for main field supply must be rated 75 C. Use copper conductors only.
2. Units with high SCCR option and terminal block must use approved fuses to meet high SCCR rating.
3. High SCCR option not available on dual point unit.

Table 20 — 30RAP Electrical Data — Single Point, No Hydronic Package

UNIT 30RAP	UNIT VOLTAGE			POWER SUPPLY QTY REQD.	NO HYDRONIC PACKAGE STANDARD LOW-SOUND AEROACOUSTIC™ FAN				NO HYDRONIC PACKAGE OPTIONAL VALUE SOUND FANS			
	V-Hz (3 Ph)	Supplied			MCA	MOCP	ICF	Rec Fuse Size	MCA	MOCP	ICF	Rec Fuse Size
		Min	Max									
011	208/230-60	187	253	1	51.0	70	186.0	60	51.6	70	186.6	60
	380-60	342	418	1	27.7	35	85.4	35	27.7	35	85.4	35
	380/415-50	342	440	1	24.7	35	85.7	30	25.1	35	86.1	30
	460-60	414	506	1	24.7	35	85.7	30	25.1	35	86.1	30
	575-60	518	633	1	18.0	25	62.1	20	18.2	25	62.3	20
016	208/230-60	187	253	1	64.5	90	269.2	80	65.1	90	269.8	80
	380-60	342	418	1	36.1	50	151.1	40	36.1	50	151.1	40
	380/415-50	342	440	1	32.5	45	144.1	40	32.9	45	144.5	40
	460-60	414	506	1	32.5	45	144.1	40	32.9	45	144.5	40
	575-60	518	633	1	24.4	35	104.0	30	24.6	35	104.2	30
018	208/230-60	187	253	1	87.2	110	270.4	100	88.4	110	271.6	100
	380-60	342	418	1	51.1	70	167.0	60	51.1	70	167.0	60
	380/415-50	342	440	1	43.4	60	136.5	50	44.2	60	137.3	50
	460-60	414	506	1	43.4	60	136.5	50	44.2	60	137.3	50
	575-60	518	633	1	34.9	45	98.2	40	35.3	45	98.6	40
020	208/230-60	187	253	1	92.6	125	286.8	110	93.8	125	288.0	110
	380-60	342	418	1	61.2	80	176.5	70	61.2	80	176.5	70
	380/415-50	342	440	1	46.1	60	148.7	60	46.9	60	149.5	60
	460-60	414	506	1	46.1	60	148.7	60	46.9	60	149.5	60
	575-60	518	633	1	37.0	50	99.1	45	37.4	50	99.5	45
025	208/230-60	187	253	1	127.4	175	363.3	150	128.6	175	364.5	150
	380-60	342	418	1	68.3	90	173.7	80	68.3	90	173.7	80
	380/415-50	342	440	1	57.8	80	178.9	70	58.6	80	179.7	70
	460-60	414	506	1	57.8	80	178.9	70	58.6	80	179.7	70
	575-60	518	633	1	49.6	60	133.7	60	50.0	60	134.1	60
030	208/230-60	187	253	1	137.6	175	407.8	175	138.8	175	409.0	175
	380-60	342	418	1	84.3	110	237.8	100	84.3	110	237.8	100
	380/415-50	342	440	1	66.3	90	211.7	80	67.1	90	212.5	80
	460-60	414	506	1	66.3	90	211.7	80	67.1	90	212.5	80
	575-60	518	633	1	58.1	80	160.5	70	58.5	80	160.9	70
035	208/230-60	187	253	1	165.4	200	359.6	175	167.2	200	361.4	200
	380-60	342	418	1	103.5	125	218.9	110	103.5	125	218.9	110
	380/415-50	342	440	1	82.4	100	185.0	90	83.6	100	186.2	90
	460-60	414	506	1	82.4	100	185.0	90	83.6	100	186.2	90
	575-60	518	633	1	66.1	80	128.2	70	66.7	80	128.8	80
040	208/230-60	187	253	1	197.8	225	395.0	225	199.6	225	396.8	225
	380-60	342	418	1	112.5	125	227.8	125	112.5	125	227.8	125
	380/415-50	342	440	1	86.4	100	188.8	100	87.6	100	190.0	100
	460-60	414	506	1	86.4	100	188.8	100	87.6	100	190.0	100
	575-60	518	633	1	68.9	80	150.9	80	69.5	80	151.5	80
045	208/230-60	187	253	1	229.6	250	468.7	250	231.4	250	470.5	250
	380-60	342	418	1	119.6	125	228.2	125	119.6	125	228.8	125
	380/415-50	342	440	1	97.9	110	223.5	110	99.1	110	224.7	110
	460-60	414	506	1	97.9	110	223.5	110	99.1	110	224.7	110
	575-60	518	633	1	81.4	100	170.7	90	82.0	100	171.3	90
050	208/230-60	187	253	1	236.0	250	471.9	250	237.8	250	473.7	250
	380-60	342	418	1	126.0	150	231.4	150	126.0	150	231.4	150
	380/415-50	342	440	1	106.9	125	228.0	125	108.1	125	229.2	125
	460-60	414	506	1	106.9	125	228.0	125	108.1	125	229.2	125
	575-60	518	633	1	91.8	110	175.9	100	92.4	110	176.5	100
055	208/230-60	187	253	1	252.2	300	526.9	300	254.6	300	529.3	300
	380-60	342	418	1	145.9	175	306.5	175	145.9	175	306.5	175
	380/415-50	342	440	1	118.3	125	267.5	125	119.9	125	269.1	125
	460-60	414	506	1	118.3	125	267.5	125	119.9	125	269.1	125
	575-60	518	633	1	102.7	125	208.9	110	103.5	125	209.7	110
060	208/230-60	187	253	1	261.2	300	531.4	300	263.6	300	533.8	300
	380-60	342	418	1	160.1	175	313.6	175	160.1	175	313.6	175
	380/415-50	342	440	1	125.9	150	271.3	150	127.5	150	272.9	150
	460-60	414	506	1	125.9	150	271.3	150	127.5	150	272.9	150
	575-60	518	633	1	110.3	125	212.7	125	111.1	125	213.5	125

LEGEND

- ICF** — Instantaneous Current Flow
- MCA** — Minimum Circuit Amps
- MOCP** — Maximum Overcurrent Protection

NOTES:

1. Units are suitable for use on electrical systems where voltage supplied to the unit terminals is not below or above the listed minimum and maximum limits. Maximum allowable phase imbalance is: voltage 2%; amps 10%.
2. All units/modules have single point primary power connection. (Each unit/module requires its own power supply.) Main power must be supplied from a field-supplied disconnect.

3. Cooler heater is wired into the control circuit so it is always operable as long as the power supply disconnect and heater safety device are on.
4. 30RAP chillers with Greenspeed® intelligence are not available on unit sizes 070-150.



Table 20 — 30RAP Electrical Data — Single Point, No Hydronic Package (cont)

UNIT 30RAP	UNIT VOLTAGE			POWER SUPPLY QTY REQD.	NO HYDRONIC PACKAGE STANDARD LOW-SOUND AEROACOUSTIC™ FAN				NO HYDRONIC PACKAGE OPTIONAL VALUE SOUND FANS			
	V-Hz (3 Ph)	Supplied			MCA	MOCP	ICF	Rec Fuse Size	MCA	MOCP	ICF	Rec Fuse Size
		Min	Max									
070	208/230-60	187	254	1	323.0	350	593.2	350	326.0	350	596.2	350
	380-60	342	418	1	198.0	225	351.5	225	198.0	225	351.5	225
	380/415-50	342	440	1	155.7	175	301.1	175	157.7	175	303.1	175
	460-60	414	506	1	155.7	175	301.1	175	157.7	175	303.1	175
	575-60	518	633	1	136.4	150	238.8	150	137.4	150	239.8	150
080	208/230-60	187	254	1	371.3	400	641.5	400	374.9	400	645.1	400
	380-60	342	418	1	214.6	225	368.1	225	214.6	225	368.1	225
	380/415-50	342	440	1	174.1	200	319.5	200	176.5	200	321.9	200
	460-60	414	506	1	174.1	200	319.5	200	176.5	200	321.9	200
	575-60	518	633	1	151.1	175	253.5	175	152.3	175	254.7	175
090	208/230-60	187	254	1	384.8	400	655.0	400	388.4	400	658.6	400
	380-60	342	418	1	235.9	250	389.4	250	235.9	250	389.4	250
	380/415-50	342	440	1	185.5	200	330.9	200	187.9	200	333.3	200
	460-60	414	506	1	185.5	200	330.9	200	187.9	200	333.3	200
	575-60	518	633	1	162.5	175	264.9	175	163.7	175	266.1	175
100	208/230-60	187	254	1	459.8	500	902.0	500	464.0	500	906.2	500
	380-60	342	418	1	242.5	250	495.9	250	242.5	250	495.9	250
	380/415-50	342	440	1	203.1	225	411.1	225	205.9	225	413.9	225
	460-60	414	506	1	203.1	225	411.1	225	205.9	225	413.9	225
	575-60	518	633	1	164.0	175	331.6	175	165.4	175	333.0	175
115	208/230-60	187	254	1	516.8	600	908.0	600	521.6	600	912.8	600
	380-60	342	418	1	271.2	300	483.2	300	271.2	300	483.2	300
	380/415-50	342	440	1	227.6	250	401.7	250	230.8	250	404.9	250
	460-60	414	506	1	227.6	250	401.7	250	230.8	250	404.9	250
	575-60	518	633	1	183.0	200	325.2	200	184.6	200	326.8	200
130	208/230-60	187	254	1	585.2	600	1027.4	600	590.6	600	1032.8	600
	380-60	342	418	1	310.5	350	563.9	350	310.5	350	563.9	350
	380/415-50	342	440	1	259.4	300	467.4	300	263.0	300	471.0	300
	460-60	414	506	1	259.4	300	467.4	300	263.0	300	471.0	300
	575-60	518	633	1	210.4	225	378.0	225	212.2	225	379.8	225
150	208/230-60	187	254	1	648.8	700	1091.0	700	654.8	700	1097.0	700
	380-60	342	418	1	347.1	350	600.5	350	347.1	350	600.5	350
	380/415-50	342	440	1	289.0	300	497.0	300	293.0	300	501.0	300
	460-60	414	506	1	289.0	300	497.0	300	293.0	300	501.0	300
	575-60	518	633	1	235.9	250	403.5	250	237.9	250	405.5	250

LEGEND

- ICF** — Instantaneous Current Flow
- MCA** — Minimum Circuit Amps
- MOCP** — Maximum Overcurrent Protection

NOTES:

1. Units are suitable for use on electrical systems where voltage supplied to the unit terminals is not below or above the listed minimum and maximum limits. Maximum allowable phase imbalance is: voltage 2%; amps 10%.
2. All units/modules have single point primary power connection. (Each unit/module requires its own power supply.) Main power must be supplied from a field-supplied disconnect.

3. Cooler heater is wired into the control circuit so it is always operable as long as the power supply disconnect and heater safety device are on.
4. 30RAP chillers with Greenspeed intelligence are not available on unit sizes 070-150.



Table 21 — 30RAP Electrical Data — Dual Point, Low-Sound Aeroacoustic™ Fan, No Hydronic Package

UNIT 30RAP	UNIT VOLTAGE			CIRCUIT 1				CIRCUIT 2			
	V-Ph-Hz	Supplied		MCA	MOCP	ICF	Rec Fuse Size	MCA	MOCP	ICF	Rec Fuse Size
		Min	Max								
070	208/230-3-60	187	254	155.6	200	425.8	175	181.4	225	451.6	200
	380-3-60	342	418	96.0	125	249.5	110	110.5	125	264.0	125
	380/415-3-50	342	440	75.0	100	220.4	90	87.4	110	232.8	100
	460-3-60	414	506	75.0	100	220.4	90	87.4	110	232.8	100
	575-3-60	518	632	65.3	80	167.7	80	77.0	100	179.4	90
080	208/230-3-60	187	254	202.7	250	438.6	225	181.4	225	451.6	200
	380-3-60	342	418	110.8	125	216.2	125	110.5	125	264.0	125
	380/415-3-50	342	440	92.5	110	213.6	100	87.4	110	232.8	100
	460-3-60	414	506	92.5	110	213.6	100	87.4	110	232.8	100
	575-3-60	518	632	79.1	90	163.2	90	77.0	100	179.4	90
090	208/230-3-60	187	254	217.4	250	487.6	250	181.4	225	451.6	200
	380-3-60	342	418	133.9	150	287.4	150	110.5	125	264.0	125
	380/415-3-50	342	440	104.8	125	250.2	125	87.4	110	232.8	100
	460-3-60	414	506	104.8	125	250.2	125	87.4	110	232.8	100
	575-3-60	518	632	91.4	110	193.8	100	77.0	100	179.4	90
100	208/230-3-60	187	254	234.8	300	677.0	300	243.8	300	635.0	300
	380-3-60	342	418	127.3	175	380.7	150	124.8	150	336.8	150
	380/415-3-50	342	440	105.0	150	313.0	125	106.3	125	280.4	125
	460-3-60	414	506	105.0	150	313.0	125	106.3	125	280.4	125
	575-3-60	518	632	85.4	125	253.0	100	85.2	110	227.4	100
115	208/230-3-60	187	254	291.8	350	683.0	350	243.8	300	635.0	300
	380-3-60	342	418	156.0	175	368.0	175	124.8	150	336.8	150
	380/415-3-50	342	440	129.5	150	303.6	150	106.3	125	280.4	125
	460-3-60	414	506	129.5	150	303.6	150	106.3	125	280.4	125
	575-3-60	518	632	104.4	125	246.6	125	85.2	110	227.4	100
130	208/230-3-60	187	254	297.8	350	689.0	350	306.2	400	748.4	350
	380-3-60	342	418	159.9	175	371.9	175	160.2	200	413.6	175
	380/415-3-50	342	440	132.4	150	306.5	150	135.2	175	343.2	150
	460-3-60	414	506	132.4	150	306.5	150	135.2	175	343.2	150
	575-3-60	518	632	106.8	125	249.0	125	110.2	125	277.8	125
150	208/230-3-60	187	254	366.2	450	808.4	400	306.2	400	748.4	350
	380-3-60	342	418	199.2	225	452.6	225	160.2	200	413.6	175
	380/415-3-50	342	440	164.2	200	372.2	175	135.2	175	343.2	150
	460-3-60	414	506	164.2	200	372.2	175	135.2	175	343.2	150
	575-3-60	518	632	134.2	150	301.8	150	110.2	125	277.8	125

LEGEND

- ICF** — Instantaneous Current Flow
- MCA** — Minimum Circuit Amps
- MOCP** — Maximum Overcurrent Protection

NOTES:

1. Units are suitable for use on electrical systems where voltage supplied to the unit terminals is not below or above the listed minimum and maximum limits. Maximum allowable phase imbalance is: voltage 2%; amps 10%.
2. All units/modules have dual point primary power connection. (Each unit/module requires its own power supply.) Main power must be supplied from a field-supplied disconnect.

3. Cooler heater is wired into the control circuit so it is always operable as long as the power supply disconnect and heater safety device are on.
4. 30RAP chillers with Greenspeed® intelligence are not available on unit sizes 070-150.



Table 22 — 30RAP Electrical Data — Dual Point, Optional Value Sound Fan, No Hydronic Package

UNIT 30RAP	UNIT VOLTAGE		CIRCUIT 1					CIRCUIT 2			
	V-Ph-Hz	Supplied		MCA	MOCP	ICF	Rec Fuse Size	MCA	MOCP	ICF	Rec Fuse Size
		Min	Max								
070	208/230-3-60	187	254	158.6	200	428.8	175	181.4	225	451.6	200
	380-3-60	342	418	96.0	125	249.5	110	110.5	125	264.0	125
	380/415-3-50	342	440	77.0	100	222.4	90	87.4	110	232.8	100
	460-3-60	414	506	77.0	100	222.4	90	87.4	110	232.8	100
	575-3-60	518	632	66.3	90	168.7	80	77.0	100	179.4	90
080	208/230-3-60	187	254	206.3	250	442.2	225	181.4	225	451.6	200
	380-3-60	342	418	110.8	125	216.2	125	110.5	125	264.0	125
	380/415-3-50	342	440	94.9	110	216.0	110	87.4	110	232.8	100
	460-3-60	414	506	94.9	110	216.0	110	87.4	110	232.8	100
	575-3-60	518	632	80.3	100	164.4	90	77.0	100	179.4	90
090	208/230-3-60	187	254	221.0	250	491.2	250	181.4	225	451.6	200
	380-3-60	342	418	133.9	150	287.4	150	110.5	125	264.0	125
	380/415-3-50	342	440	107.2	125	252.6	125	87.4	110	232.8	100
	460-3-60	414	506	107.2	125	252.6	125	87.4	110	232.8	100
	575-3-60	518	632	92.6	110	195.0	100	77.0	100	179.4	90
100	208/230-3-60	187	254	239.0	300	681.2	300	243.8	300	635.0	300
	380-3-60	342	418	127.3	175	380.7	150	124.8	150	336.8	150
	380/415-3-50	342	440	107.8	125	315.8	125	106.3	125	280.4	125
	460-3-60	414	506	107.8	125	315.8	125	106.3	125	280.4	125
	575-3-60	518	632	86.8	110	254.4	100	85.2	110	227.4	100
115	208/230-3-60	187	254	296.6	350	687.8	350	243.8	300	635.0	300
	380-3-60	342	418	156.0	175	368.0	175	124.8	150	336.8	150
	380/415-3-50	342	440	132.7	150	306.8	150	106.3	125	280.4	125
	460-3-60	414	506	132.7	150	306.8	150	106.3	125	280.4	125
	575-3-60	518	632	106.0	125	248.2	125	85.2	110	227.4	100
130	208/230-3-60	187	254	303.2	350	694.4	350	306.2	400	748.4	350
	380-3-60	342	418	159.9	175	371.9	175	160.2	200	413.6	175
	380/415-3-50	342	440	136.0	150	310.1	150	135.2	175	343.2	150
	460-3-60	414	506	136.0	150	310.1	150	135.2	175	343.2	150
	575-3-60	518	632	108.6	125	250.8	125	110.2	125	277.8	125
150	208/230-3-60	187	254	372.2	450	814.4	400	306.2	400	748.4	350
	380-3-60	342	418	199.2	225	452.6	225	160.2	200	413.6	175
	380/415-3-50	342	440	168.2	200	376.2	200	135.2	175	343.2	150
	460-3-60	414	506	168.2	200	376.2	200	135.2	175	343.2	150
	575-3-60	518	632	136.2	150	303.8	150	110.2	125	277.8	125

LEGEND

- ICF** — Instantaneous Current Flow
- MCA** — Minimum Circuit Amps
- MOCP** — Maximum Overcurrent Protection

- 3. Cooler heater is wired into the control circuit so it is always operable as long as the power supply disconnect and heater safety device are on.
- 4. 30RAP chillers with Greenspeed® intelligence are not available on unit sizes 070-150.

NOTES:

- 1. Units are suitable for use on electrical systems where voltage supplied to the unit terminals is not below or above the listed minimum and maximum limits. Maximum allowable phase imbalance is: voltage 2%; amps 10%.
- 2. All units/modules have dual point primary power connection. (Each unit/module requires its own power supply.) Main power must be supplied from a field-supplied disconnect.



Table 23 — 30RAP Electrical Data — Single Point, Hydronic Package with Standard Low-Sound Aeroacoustic™ Fan (60 Hz Only)

30RAP UNIT SIZE	VOLTAGE V-Hz (3 Ph)	PUMP SIZE 1.5 hp				PUMP SIZE 3.0 hp				PUMP SIZE 5.0 hp			
		MCA	MOCP	ICF	REC FUSE	MCA	MOCP	ICF	REC FUSE	MCA	MOCP	ICF	REC FUSE
011	208/230-60	55.3	70	190.3	70	58.9	80	193.9	70	63.6	80	198.6	70
	380-60	30.1	40	87.8	35	32.1	40	89.8	35	34.7	45	92.4	40
	460-60	26.8	35	87.8	30	28.4	35	89.4	35	30.5	40	91.5	35
	575-60	19.6	25	63.7	25	21.0	25	65.1	25	22.6	30	66.7	25
016	208/230-60	68.8	90	273.5	80	72.4	100	277.1	80	77.1	100	281.8	90
	380-60	38.5	50	153.5	45	40.5	50	155.5	45	43.1	50	158.0	50
	460-60	34.6	45	146.2	40	36.2	50	147.8	40	38.3	50	149.9	45
	575-60	26.0	35	105.6	30	27.4	35	107.0	30	29.0	40	108.6	35
018	208/230-60	91.5	110	274.7	100	95.1	125	278.3	110	99.8	125	283.0	110
	380-60	53.5	70	169.4	60	55.5	70	171.4	70	58.1	70	174.0	70
	460-60	45.5	60	138.6	50	47.1	60	140.2	60	49.2	60	142.3	60
	575-60	36.5	45	99.8	40	37.9	50	101.2	45	39.5	50	102.8	45
020	208/230-60	96.9	125	291.1	110	100.5	125	294.7	110	105.2	125	299.4	125
	380-60	63.6	80	178.9	70	65.6	80	180.9	80	68.2	90	183.5	80
	460-60	48.2	60	150.8	60	49.8	60	152.4	60	51.9	60	154.5	60
	575-60	38.6	50	100.7	45	40.0	50	102.1	45	41.6	50	103.7	50
025	208/230-60	131.7	175	367.6	150	135.3	175	371.2	150	140.0	175	375.9	175
	380-60	70.7	90	176.1	80	72.7	90	178.1	80	75.3	100	180.7	90
	460-60	59.9	80	181.0	70	61.5	80	182.6	70	63.6	80	184.7	70
	575-60	51.2	70	135.3	60	52.6	70	136.7	60	54.2	70	138.3	60
030	208/230-60	141.9	175	412.1	175	145.5	200	415.7	175	150.2	200	420.4	175
	380-60	86.7	110	240.2	100	88.7	110	242.2	100	91.3	125	244.8	100
	460-60	68.4	90	213.8	80	70.0	90	215.4	80	72.1	90	217.5	80
	575-60	59.7	80	162.1	70	61.1	80	163.5	70	62.7	80	165.1	70
035	208/230-60	—	—	—	—	173.3	200	367.5	200	178.0	200	372.2	200
	380-60	—	—	—	—	107.9	125	223.3	125	110.5	125	225.9	125
	460-60	—	—	—	—	86.1	100	188.7	100	88.2	100	190.8	100
	575-60	—	—	—	—	69.1	80	131.2	80	70.7	80	132.8	80
040	208/230-60	—	—	—	—	205.7	250	402.9	225	210.4	250	407.6	225
	380-60	—	—	—	—	116.9	125	232.2	125	119.5	125	234.8	125
	460-60	—	—	—	—	90.1	100	192.5	100	92.2	110	194.6	100
	575-60	—	—	—	—	71.9	80	153.9	80	73.5	80	155.5	80
045	208/230-60	—	—	—	—	237.5	250	476.6	250	242.2	250	481.3	250
	380-60	—	—	—	—	124.0	150	232.6	150	126.6	150	235.2	150
	460-60	—	—	—	—	101.6	110	227.2	110	103.7	125	229.3	110
	575-60	—	—	—	—	84.4	100	173.7	90	86.0	100	175.3	100
050	208/230-60	—	—	—	—	243.9	250	479.8	250	248.6	250	484.5	250
	380-60	—	—	—	—	130.4	150	235.8	150	133.0	150	238.4	150
	460-60	—	—	—	—	110.6	125	231.7	125	112.7	125	233.8	125
	575-60	—	—	—	—	94.8	110	178.9	100	96.4	110	180.5	110
055	208/230-60	—	—	—	—	260.1	300	534.8	300	264.8	300	539.5	300
	380-60	—	—	—	—	150.3	175	310.9	175	152.9	175	313.5	175
	460-60	—	—	—	—	122.0	125	271.2	125	124.1	150	273.3	150
	575-60	—	—	—	—	105.7	125	211.9	125	107.3	125	213.5	125
060	208/230-60	—	—	—	—	269.1	300	539.3	300	273.8	300	544.0	300
	380-60	—	—	—	—	164.5	175	318.0	175	167.1	200	320.6	200
	460-60	—	—	—	—	129.6	150	275.0	150	131.7	150	277.1	150
	575-60	—	—	—	—	113.3	125	215.7	125	114.9	125	217.3	125

LEGEND

- ICF** — Instantaneous Current Flow
MCA — Minimum Circuit Amps
MOCP — Maximum Overcurrent Protection

NOTES:

- Units are suitable for use on electrical systems where voltage supplied to the unit terminals is not below or above the listed minimum and maximum limits. Maximum allowable phase imbalance is: voltage 2%; amps 10%.
- All units/modules have single point primary power connection. (Each unit/module requires its own power supply.) Main power must be supplied from a field-supplied disconnect.

3. Cooler heater is wired into the control circuit so it is always operable as long as the power supply disconnect and heater safety device are on.
4. 30RAP chillers with Greenspeed intelligence are not available on unit sizes 070-150.



Table 23 — 30RAP Electrical Data — Single Point, Hydronic Package with Standard Low-Sound Aeroacoustic™ Fan (60 Hz Only) (cont)

30RAP UNIT SIZE	VOLTAGE V-Hz (3 Ph)	PUMP SIZE 7.5 hp				PUMP SIZE 10.0 hp				PUMP SIZE 15.0 hp			
		MCA	MOCP	ICF	REC FUSE	MCA	MOCP	ICF	REC FUSE	MCA	MOCP	ICF	REC FUSE
011	208/230-60	—	—	—	—	—	—	—	—	—	—	—	—
	380-60	—	—	—	—	—	—	—	—	—	—	—	—
	460-60	—	—	—	—	—	—	—	—	—	—	—	—
	575-60	—	—	—	—	—	—	—	—	—	—	—	—
016	208/230-60	—	—	—	—	—	—	—	—	—	—	—	—
	380-60	—	—	—	—	—	—	—	—	—	—	—	—
	460-60	—	—	—	—	—	—	—	—	—	—	—	—
	575-60	—	—	—	—	—	—	—	—	—	—	—	—
018	208/230-60	—	—	—	—	—	—	—	—	—	—	—	—
	380-60	—	—	—	—	—	—	—	—	—	—	—	—
	460-60	—	—	—	—	—	—	—	—	—	—	—	—
	575-60	—	—	—	—	—	—	—	—	—	—	—	—
020	208/230-60	—	—	—	—	—	—	—	—	—	—	—	—
	380-60	—	—	—	—	—	—	—	—	—	—	—	—
	460-60	—	—	—	—	—	—	—	—	—	—	—	—
	575-60	—	—	—	—	—	—	—	—	—	—	—	—
025	208/230-60	—	—	—	—	—	—	—	—	—	—	—	—
	380-60	—	—	—	—	—	—	—	—	—	—	—	—
	460-60	—	—	—	—	—	—	—	—	—	—	—	—
	575-60	—	—	—	—	—	—	—	—	—	—	—	—
030	208/230-60	—	—	—	—	—	—	—	—	—	—	—	—
	380-60	—	—	—	—	—	—	—	—	—	—	—	—
	460-60	—	—	—	—	—	—	—	—	—	—	—	—
	575-60	—	—	—	—	—	—	—	—	—	—	—	—
035	208/230-60	183.9	200	378.1	200	—	—	—	—	—	—	—	—
	380-60	113.9	125	229.3	125	—	—	—	—	—	—	—	—
	460-60	91.1	100	193.7	100	—	—	—	—	—	—	—	—
	575-60	73.1	80	135.2	80	—	—	—	—	—	—	—	—
040	208/230-60	216.3	250	413.5	250	—	—	—	—	—	—	—	—
	380-60	122.9	125	238.2	125	—	—	—	—	—	—	—	—
	460-60	95.1	110	197.5	100	—	—	—	—	—	—	—	—
	575-60	75.9	90	157.9	80	—	—	—	—	—	—	—	—
045	208/230-60	248.1	250	487.2	250	—	—	—	—	—	—	—	—
	380-60	130.0	150	238.6	150	—	—	—	—	—	—	—	—
	460-60	106.6	125	232.2	125	—	—	—	—	—	—	—	—
	575-60	88.4	100	177.7	100	—	—	—	—	—	—	—	—
050	208/230-60	254.5	300	490.4	300	261.0	300	496.9	300	—	—	—	—
	380-60	136.4	150	241.8	150	140.0	150	245.4	150	—	—	—	—
	460-60	115.6	125	236.7	125	118.4	125	239.5	125	—	—	—	—
	575-60	98.8	110	182.9	110	101.0	110	185.1	110	—	—	—	—
055	208/230-60	270.7	300	545.4	300	277.2	300	551.9	300	—	—	—	—
	380-60	156.3	175	316.9	175	159.9	175	320.5	175	—	—	—	—
	460-60	127.0	150	276.2	150	129.8	150	279.0	150	—	—	—	—
	575-60	109.7	125	215.9	125	111.9	125	218.1	125	—	—	—	—
060	208/230-60	279.7	300	549.9	300	286.2	300	556.4	300	—	—	—	—
	380-60	170.5	200	324.0	200	174.1	200	327.6	200	—	—	—	—
	460-60	134.6	150	280.0	150	137.4	150	282.8	150	—	—	—	—
	575-60	117.3	125	219.7	125	119.5	125	221.9	125	—	—	—	—

LEGEND

- ICF** — Instantaneous Current Flow
- MCA** — Minimum Circuit Amps
- MOCP** — Maximum Overcurrent Protection

NOTES:

1. Units are suitable for use on electrical systems where voltage supplied to the unit terminals is not below or above the listed minimum and maximum limits. Maximum allowable phase imbalance is: voltage 2%; amps 10%.
2. All units/modules have single point primary power connection. (Each unit/module requires its own power supply.) Main power must be supplied from a field-supplied disconnect.
3. Cooler heater is wired into the control circuit so it is always operable as long as the power supply disconnect and heater safety device are on.

4. Power draw control circuits include both crankcase heaters (sizes 070-150 only) and cooler heaters (where used). Each compressor on sizes 070-090 has a crankcase heater which draws 90 watts of power, while each compressor on sizes 100-150 has a crankcase heater which draws 56 watts of power.
5. 30RAP chillers with Greenspeed® intelligence are not available on unit sizes 070-150.



Table 23 — 30RAP Electrical Data — Single Point, Hydronic Package with Standard Low-Sound Aeroacoustic™ Fan (60 Hz Only) (cont)

30RAP UNIT SIZE	VOLTAGE V-Hz (3 Ph)	PUMP SIZE 1.5 hp				PUMP SIZE 3.0 hp				PUMP SIZE 5.0 hp			
		MCA	MOCP	ICF	REC FUSE	MCA	MOCP	ICF	REC FUSE	MCA	MOCP	ICF	REC FUSE
070	208/230-60	—	—	—	—	—	—	—	—	—	—	—	—
	380-60	—	—	—	—	—	—	—	—	—	—	—	—
	460-60	—	—	—	—	—	—	—	—	—	—	—	—
	575-60	—	—	—	—	—	—	—	—	—	—	—	—
080	208/230-60	—	—	—	—	—	—	—	—	—	—	—	—
	380-60	—	—	—	—	—	—	—	—	—	—	—	—
	460-60	—	—	—	—	—	—	—	—	—	—	—	—
	575-60	—	—	—	—	—	—	—	—	—	—	—	—
090	208/230-60	—	—	—	—	—	—	—	—	—	—	—	—
	380-60	—	—	—	—	—	—	—	—	—	—	—	—
	460-60	—	—	—	—	—	—	—	—	—	—	—	—
	575-60	—	—	—	—	—	—	—	—	—	—	—	—
100	208/230-60	—	—	—	—	—	—	—	—	—	—	—	—
	380-60	—	—	—	—	—	—	—	—	—	—	—	—
	460-60	—	—	—	—	—	—	—	—	—	—	—	—
	575-60	—	—	—	—	—	—	—	—	—	—	—	—
115	208/230-60	—	—	—	—	—	—	—	—	—	—	—	—
	380-60	—	—	—	—	—	—	—	—	—	—	—	—
	460-60	—	—	—	—	—	—	—	—	—	—	—	—
	575-60	—	—	—	—	—	—	—	—	—	—	—	—
130	208/230-60	—	—	—	—	—	—	—	—	—	—	—	—
	380-60	—	—	—	—	—	—	—	—	—	—	—	—
	460-60	—	—	—	—	—	—	—	—	—	—	—	—
	575-60	—	—	—	—	—	—	—	—	—	—	—	—
150	208/230-60	—	—	—	—	—	—	—	—	664.2	700	1106.4	700
	380-60	—	—	—	—	—	—	—	—	355.2	400	608.6	400
	460-60	—	—	—	—	—	—	—	—	296.1	300	504.1	300
	575-60	—	—	—	—	—	—	—	—	241.3	250	408.9	250

30RAP UNIT SIZE	VOLTAGE V-Hz (3 Ph)	PUMP SIZE 7.5 hp				PUMP SIZE 10.0 hp				PUMP SIZE 15.0 hp			
		MCA	MOCP	ICF	REC FUSE	MCA	MOCP	ICF	REC FUSE	MCA	MOCP	ICF	REC FUSE
070	208/230-60	341.5	350	611.7	350	348.0	400	618.2	400	—	—	—	—
	380-60	208.4	225	361.9	225	212.0	225	365.5	225	—	—	—	—
	460-60	164.4	175	309.8	175	167.2	175	312.6	175	—	—	—	—
	575-60	143.4	150	245.8	150	145.6	150	248.0	150	—	—	—	—
080	208/230-60	389.8	400	660.0	400	396.3	450	666.5	450	408.0	450	678.2	450
	380-60	225.0	250	378.5	250	228.6	250	382.1	250	235.6	250	389.1	250
	460-60	182.8	200	328.2	200	185.6	200	331.0	200	191.1	200	336.5	200
	575-60	158.1	175	260.5	175	160.3	175	262.7	175	165.1	175	267.5	175
090	208/230-60	403.3	450	673.5	450	409.8	450	680.0	450	421.5	450	691.7	450
	380-60	246.3	250	399.8	250	249.9	250	403.4	250	256.9	300	410.4	300
	460-60	194.2	200	339.6	200	197.0	200	342.4	200	202.5	225	347.9	225
	575-60	169.5	175	271.9	175	171.7	175	274.1	175	176.5	200	278.9	200
100	208/230-60	478.3	500	920.5	500	484.8	500	927.0	500	496.5	500	938.7	500
	380-60	252.9	300	506.3	300	256.5	300	509.9	300	263.5	300	516.9	300
	460-60	211.8	250	419.8	225	214.6	250	422.0	250	220.1	250	428.1	250
	575-60	171.0	200	338.6	200	173.2	200	340.8	200	178.0	200	345.6	200
115	208/230-60	535.3	600	926.5	600	541.8	600	933.0	600	553.5	600	944.7	600
	380-60	281.6	300	493.6	300	285.2	300	497.2	300	292.2	300	504.2	300
	460-60	236.3	250	410.4	250	239.1	250	413.2	250	244.6	250	418.7	250
	575-60	190.0	200	332.2	200	192.2	200	334.4	200	197.0	200	339.2	200
130	208/230-60	603.7	700	1045.9	700	610.2	700	1052.4	700	621.9	700	1064.1	700
	380-60	320.9	350	574.3	350	324.5	350	577.9	350	331.5	350	584.9	350
	460-60	268.1	300	476.1	300	270.9	300	478.9	300	276.4	300	484.4	300
	575-60	217.4	250	385.0	250	219.6	250	387.2	250	224.4	250	392.0	250
150 Dual Pump	208/230-60	667.3	700	1109.5	700	673.8	700	1116.0	700	685.5	700	1127.7	700
	380-60	357.5	400	610.9	400	361.1	400	614.5	400	368.1	400	621.5	400
	460-60	297.7	300	505.7	300	300.5	350	508.5	350	306.0	350	514.0	350
	575-60	242.9	250	410.5	250	245.1	250	412.7	250	249.9	250	417.5	250

LEGEND

- ICF** — Instantaneous Current Flow
- MCA** — Minimum Circuit Amps
- MOCP** — Maximum Overcurrent Protection

NOTES:

1. Units are suitable for use on electrical systems where voltage supplied to the unit terminals is not below or above the listed minimum and maximum limits. Maximum allowable phase imbalance is: voltage 2%; amps 10%.
2. All units/modules have single point primary power connection. (Each unit/module requires its own power supply.) Main power must be supplied from a field-supplied disconnect.
3. Cooler heater is wired into the control circuit so it is always operable as long as the power supply disconnect and heater safety device are on.
4. Power draw control circuits include both crankcase heaters (sizes 070-150 only) and cooler heaters (where used). Each compressor on sizes

070-090 has a crankcase heater which draws 90 watts of power, while each compressor on sizes 100-150 has a crankcase heater which draws 56 watts of power.

5. 30RAP chillers with Greenspeed® intelligence are not available on unit sizes 070-150.
6. All data is the same for single pump or dual pump except for size 150 with 7.5 hp pump.



Table 24 — 30RAP Electrical Data — Dual Point, Hydronic Package with Standard Low-Sound Aeroacoustic™ Fan (60 Hz Only)

30RAP UNIT SIZE	VOLTAGE V-Ph-Hz	PUMP SIZE 3.0 HP CIRCUIT 1				PUMP SIZE 3.0 HP CIRCUIT 2			
		MCA	MOCP	ICF	REC FUSE	MCA	MOCP	ICF	REC FUSE
150	208/230-3-60	366.2	450	808.4	400	321.6	400	763.8	350
	380-3-60	199.2	225	452.6	225	168.3	200	421.7	200
	460-3-60	164.2	200	372.2	175	142.3	175	350.3	175
	575-3-60	134.2	150	301.8	150	115.6	125	283.2	125
30RAP UNIT SIZE	VOLTAGE V-Ph-Hz	PUMP SIZE 5.0 HP CIRCUIT 1				PUMP SIZE 5.0 HP CIRCUIT 2			
		MCA	MOCP	ICF	REC FUSE	MCA	MOCP	ICF	REC FUSE
070	208/230-3-60	155.6	200	425.8	175	199.9	250	470.1	225
	380-3-60	96.0	125	249.5	110	120.9	150	274.4	150
	460-3-60	75.0	100	220.4	90	96.1	110	241.5	110
	575-3-60	65.3	80	167.7	80	84.0	100	186.4	90
080	208/230-3-60	202.7	250	438.6	225	199.9	250	470.1	225
	380-3-60	110.8	125	216.2	125	120.9	150	274.4	150
	460-3-60	92.5	110	213.6	100	96.1	110	241.5	110
	575-3-60	79.1	90	163.2	90	84.0	100	186.4	90
090	208/230-3-60	217.4	250	487.6	250	199.9	250	470.1	225
	380-3-60	133.9	150	287.4	150	120.9	150	274.4	150
	460-3-60	104.8	125	250.2	125	96.1	110	241.5	110
	575-3-60	91.4	110	193.8	100	84.0	100	186.4	90
100	208/230-3-60	234.8	300	677.0	300	262.3	300	653.5	300
	380-3-60	127.3	175	380.7	150	135.2	150	347.2	150
	460-3-60	105.0	125	313.0	125	115.0	125	289.1	125
	575-3-60	85.4	110	253.0	100	92.2	110	234.4	100
115	208/230-3-60	291.8	350	683.0	350	262.3	300	653.5	300
	380-3-60	156.0	175	368.0	175	135.2	150	347.2	150
	460-3-60	129.5	150	303.6	150	115.0	125	289.1	125
	575-3-60	104.4	125	246.6	125	92.2	110	234.4	100
130	208/230-3-60	297.8	350	689.0	350	324.7	400	766.9	350
	380-3-60	159.9	175	371.9	175	170.6	200	424.0	200
	460-3-60	132.4	150	306.5	150	143.9	175	351.9	175
	575-3-60	106.8	125	249.0	125	117.2	150	284.8	150
150 Dual Pump	208/230-3-60	366.2	450	808.4	400	324.7	400	766.9	350
	380-3-60	199.2	225	452.6	225	170.6	200	424.0	200
	460-3-60	164.2	200	372.2	175	143.9	175	351.9	175
	575-3-60	134.2	150	301.8	150	117.2	150	284.8	150

LEGEND

- ICF** — Instantaneous Current Flow
- MCA** — Minimum Circuit Amps
- MOCP** — Maximum Overcurrent Protection

NOTES:

1. Units are suitable for use on electrical systems where voltage supplied to the unit terminals is not below or above the listed minimum and maximum limits. Maximum allowable phase imbalance is: voltage 2%; amps 10%.
2. All units/modules have single point primary power connection. (Each unit/module requires its own power supply.) Main power must be supplied from a field-supplied disconnect.

3. Cooler heater is wired into the control circuit so it is always operable as long as the power supply disconnect and heater safety device are on.
4. 30RAP chillers with Greenspeed® intelligence are not available on unit sizes 070-150.



Table 24 — 30RAP Electrical Data — Dual Point, Hydronic Package with Standard Low-Sound Aeroacoustic™ Fan (60 Hz Only) (cont)

30RAP UNIT SIZE	VOLTAGE V-Ph-Hz	PUMP SIZE 10.0 HP CIRCUIT 1				PUMP SIZE 10.0 HP CIRCUIT 2			
		MCA	MOCP	ICF	REC FUSE	MCA	MOCP	ICF	REC FUSE
070	208/230-3-60	155.6	200	425.8	175	206.4	250	476.6	225
	380-3-60	96.0	125	249.5	110	124.5	150	278.0	150
	460-3-60	75.0	100	220.4	90	98.9	125	244.3	110
	575-3-60	65.3	80	167.7	80	86.2	100	188.6	100
080	208/230-3-60	202.7	250	438.6	225	206.4	250	476.6	225
	380-3-60	110.8	125	216.2	125	124.5	150	278.0	150
	460-3-60	92.5	110	213.6	100	98.9	125	244.3	110
	575-3-60	79.1	90	163.2	90	86.2	100	188.6	100
090	208/230-3-60	217.4	250	487.6	250	206.4	250	476.6	225
	380-3-60	133.9	150	287.4	150	124.5	150	278.0	150
	460-3-60	104.8	125	250.2	125	98.9	125	244.3	110
	575-3-60	91.4	110	193.8	100	86.2	100	188.6	100
100	208/230-3-60	234.8	300	677.0	300	268.8	300	660.0	300
	380-3-60	127.3	175	380.7	150	138.8	175	350.8	150
	460-3-60	105.0	125	313.0	125	117.8	150	291.9	150
	575-3-60	85.4	110	253.0	100	94.4	110	236.6	110
115	208/230-3-60	291.8	350	683.0	350	268.8	300	660.0	300
	380-3-60	156.0	175	368.0	175	138.8	175	350.8	150
	460-3-60	129.5	150	303.6	150	117.8	150	291.9	150
	575-3-60	104.4	125	246.6	125	94.4	110	236.6	110
130	208/230-3-60	297.8	350	689.0	350	331.2	400	773.4	400
	380-3-60	159.9	175	371.9	175	174.2	225	427.6	200
	460-3-60	132.4	150	306.5	150	146.7	175	354.7	150
	575-3-60	106.8	125	249.0	125	119.4	150	287.0	150
150	208/230-3-60	366.2	450	808.4	400	331.2	400	773.4	400
	380-3-60	199.2	225	452.6	225	174.2	225	427.6	200
	460-3-60	164.2	200	372.2	175	146.7	175	354.7	150
	575-3-60	134.2	150	301.8	150	119.4	150	287.0	150

30RAP UNIT SIZE	VOLTAGE V-Ph-Hz	PUMP SIZE 15.0 HP CIRCUIT 1				PUMP SIZE 15.0 HP CIRCUIT 2			
		MCA	MOCP	ICF	REC FUSE	MCA	MOCP	ICF	REC FUSE
070	208/230-3-60	—	—	—	—	—	—	—	—
	380-3-60	—	—	—	—	—	—	—	—
	460-3-60	—	—	—	—	—	—	—	—
	575-3-60	—	—	—	—	—	—	—	—
080	208/230-3-60	202.7	250	438.6	225	218.1	250	488.3	250
	380-3-60	110.8	125	216.2	125	131.5	150	285.0	150
	460-3-60	92.5	110	213.6	100	104.4	125	249.8	125
	575-3-60	79.1	90	163.2	90	91.0	110	193.4	100
090	208/230-3-60	217.4	250	487.6	250	218.1	250	488.3	250
	380-3-60	133.9	150	287.4	150	131.5	150	285.0	150
	460-3-60	104.8	125	250.2	125	104.4	125	249.8	125
	575-3-60	91.4	110	193.8	100	91.0	110	193.4	100
100	208/230-3-60	234.8	300	677.0	300	280.5	350	671.7	300
	380-3-60	127.3	175	380.7	150	145.8	175	357.8	175
	460-3-60	105.0	125	313.0	125	123.3	150	297.4	150
	575-3-60	85.4	110	253.0	100	99.2	125	241.4	110
115	208/230-3-60	291.8	350	683.0	350	280.5	350	671.7	300
	380-3-60	156.0	175	368.0	175	145.8	175	357.8	175
	460-3-60	129.5	150	303.6	150	123.3	150	297.4	150
	575-3-60	104.4	125	246.6	125	99.2	125	241.4	110
130	208/230-3-60	297.8	350	689.0	350	342.9	400	785.1	400
	380-3-60	159.9	175	371.9	175	181.2	225	434.6	200
	460-3-60	132.4	150	306.5	150	152.2	175	360.2	175
	575-3-60	106.8	125	249.0	125	124.2	150	291.8	150
150	208/230-3-60	366.2	450	808.4	400	342.9	400	785.1	400
	380-3-60	199.2	225	452.6	225	181.2	225	434.6	200
	460-3-60	164.2	200	372.2	175	152.2	175	360.2	175
	575-3-60	134.2	150	301.8	150	124.2	150	291.8	150

LEGEND

- ICF** — Instantaneous Current Flow
- MCA** — Minimum Circuit Amps
- MOCP** — Maximum Overcurrent Protection

- 3. Cooler heater is wired into the control circuit so it is always operable as long as the power supply disconnect and heater safety device are on.
- 4. 30RAP chillers with Greenspeed intelligence are not available on unit sizes 070-150.

NOTES:

- 1. Units are suitable for use on electrical systems where voltage supplied to the unit terminals is not below or above the listed minimum and maximum limits. Maximum allowable phase imbalance is: voltage 2%; amps 10%.
- 2. All units/modules have single point primary power connection. (Each unit/module requires its own power supply.) Main power must be supplied from a field-supplied disconnect.



Table 25 — 30RAP Electrical Data — Single Point, Hydronic Package with Optional Value Sound Fans (60 Hz Only)

30RAP UNIT SIZE	VOLTAGE V-Hz (3 Ph)	PUMP SIZE 1.5 HP				PUMP SIZE 3.0 HP				PUMP SIZE 5.0 HP			
		MCA	MOCP	ICF	REC FUSE	MCA	MOCP	ICF	REC FUSE	MCA	MOCP	ICF	REC FUSE
Not Applicable011	208/230-60	55.9	70	190.9	70	59.5	80	194.5	70	64.2	80	199.2	70
	380-60	30.1	40	87.8	35	32.1	40	89.8	35	34.7	45	92.4	40
	460-60	27.2	35	88.2	30	28.8	40	89.8	35	30.9	40	91.9	35
	575-60	19.8	25	63.9	25	21.2	25	65.3	25	22.8	30	66.9	25
016	208/230-60	69.4	90	274.1	80	73.0	100	277.7	90	77.7	100	282.4	90
	380-60	38.5	50	153.5	45	40.5	50	155.5	45	43.1	50	158.1	50
	460-60	35.0	45	146.6	40	36.6	50	148.2	45	38.7	50	150.3	45
	575-60	26.2	35	105.8	30	27.6	35	107.2	35	29.2	40	108.8	35
018	208/230-60	92.7	125	275.9	110	96.3	125	279.5	110	101.0	125	284.2	110
	380-60	53.5	70	169.4	60	55.5	70	171.4	70	58.1	70	174.0	70
	460-60	46.3	60	139.4	60	47.9	60	141.0	60	50.0	60	143.1	60
	575-60	36.9	50	100.2	45	38.3	50	101.6	45	39.9	50	103.2	45
020	208/230-60	98.1	125	292.3	110	101.7	125	295.9	125	106.4	125	300.6	125
	380-60	63.6	80	178.9	70	65.6	80	180.9	80	68.2	90	183.5	80
	460-60	49.0	60	151.6	60	50.6	60	153.2	60	52.7	70	155.3	60
	575-60	39.0	50	101.1	45	40.4	50	102.5	45	42.0	50	104.1	50
025	208/230-60	132.9	175	368.8	150	136.5	175	372.4	150	141.2	175	377.1	175
	380-60	70.7	90	176.1	80	72.7	90	178.1	80	75.3	100	180.7	90
	460-60	60.7	80	181.8	70	62.3	80	183.4	70	64.4	80	185.5	80
	575-60	51.6	70	135.7	60	53.0	70	137.1	60	54.6	70	138.7	60
030	208/230-60	143.1	175	413.3	175	146.7	200	416.9	175	151.4	200	421.6	175
	380-60	86.7	110	240.2	100	88.7	110	242.2	100	91.3	125	244.8	100
	460-60	69.2	90	214.6	80	70.8	90	216.2	80	72.9	90	218.3	80
	575-60	60.1	80	162.5	70	61.5	80	163.9	70	63.1	80	165.5	70
035	208/230-60	—	—	—	—	175.1	200	369.3	200	179.8	200	374.0	200
	380-60	—	—	—	—	107.9	125	223.2	125	110.5	125	225.9	125
	460-60	—	—	—	—	87.3	100	189.9	100	89.4	100	192.0	100
	575-60	—	—	—	—	69.7	80	131.8	80	71.3	80	133.4	80
040	208/230-60	—	—	—	—	207.5	250	404.7	225	212.2	250	409.4	225
	380-60	—	—	—	—	116.9	125	232.2	125	119.5	125	234.8	125
	460-60	—	—	—	—	91.3	100	193.7	100	93.4	110	195.8	100
	575-60	—	—	—	—	72.5	80	154.5	80	74.1	80	156.1	80
045	208/230-60	—	—	—	—	239.3	250	478.4	250	244.0	250	483.1	250
	380-60	—	—	—	—	124.0	150	232.6	150	126.6	150	235.2	150
	460-60	—	—	—	—	102.8	125	228.4	110	104.9	125	230.5	125
	575-60	—	—	—	—	85.0	100	174.3	90	86.6	100	175.9	100
050	208/230-60	—	—	—	—	245.7	250	481.6	250	250.4	300	486.3	300
	380-60	—	—	—	—	130.4	150	235.8	150	133.0	150	238.4	150
	460-60	—	—	—	—	111.8	125	232.9	125	113.9	125	235.0	125
	575-60	—	—	—	—	95.4	110	179.5	110	97.0	110	181.1	110
055	208/230-60	—	—	—	—	262.5	300	537.2	300	267.2	300	541.9	300
	380-60	—	—	—	—	150.3	175	310.9	175	152.9	175	313.5	175
	460-60	—	—	—	—	123.6	150	272.8	150	125.7	150	274.9	150
	575-60	—	—	—	—	106.5	125	212.7	125	108.1	125	214.3	125
060	208/230-60	—	—	—	—	271.5	300	541.7	300	276.2	300	546.4	300
	380-60	—	—	—	—	164.5	175	318.0	175	167.1	200	320.6	200
	460-60	—	—	—	—	131.2	150	276.6	150	133.3	150	278.7	150
	575-60	—	—	—	—	114.1	125	216.5	125	115.7	125	218.1	125

LEGEND

- ICF** — Instantaneous Current Flow
- MCA** — Minimum Circuit Amps
- MOCP** — Maximum Overcurrent Protection

NOTES:

1. Units are suitable for use on electrical systems where voltage supplied to the unit terminals is not below or above the listed minimum and maximum limits. Maximum allowable phase imbalance is: voltage 2%; amps 10%.
2. All units/modules have single point primary power connection. (Each unit/module requires its own power supply.) Main power must be supplied from a field-supplied disconnect.

3. Cooler heater is wired into the control circuit so it is always operable as long as the power supply disconnect and heater safety device are on.
4. 30RAP chillers with Greenspeed® intelligence are not available on unit sizes 070-150.



Table 25 — 30RAP Electrical Data — Single Point, Hydronic Package with Optional Value Sound Fans (60 Hz Only) (cont)

30RAP UNIT SIZE	VOLTAGE V-Hz (3 Ph)	PUMP SIZE 7.5 HP				PUMP SIZE 10.0 HP				PUMP SIZE 15.0 HP			
		MCA	MOCP	ICF	REC FUSE	MCA	MOCP	ICF	REC FUSE	MCA	MOCP	ICF	REC FUSE
011	208/230-60	—	—	—	—	—	—	—	—	—	—	—	—
	380-60	—	—	—	—	—	—	—	—	—	—	—	—
	460-60	—	—	—	—	—	—	—	—	—	—	—	—
	575-60	—	—	—	—	—	—	—	—	—	—	—	—
016	208/230-60	—	—	—	—	—	—	—	—	—	—	—	—
	380-60	—	—	—	—	—	—	—	—	—	—	—	—
	460-60	—	—	—	—	—	—	—	—	—	—	—	—
	575-60	—	—	—	—	—	—	—	—	—	—	—	—
018	208/230-60	—	—	—	—	—	—	—	—	—	—	—	—
	380-60	—	—	—	—	—	—	—	—	—	—	—	—
	460-60	—	—	—	—	—	—	—	—	—	—	—	—
	575-60	—	—	—	—	—	—	—	—	—	—	—	—
020	208/230-60	—	—	—	—	—	—	—	—	—	—	—	—
	380-60	—	—	—	—	—	—	—	—	—	—	—	—
	460-60	—	—	—	—	—	—	—	—	—	—	—	—
	575-60	—	—	—	—	—	—	—	—	—	—	—	—
025	208/230-60	—	—	—	—	—	—	—	—	—	—	—	—
	380-60	—	—	—	—	—	—	—	—	—	—	—	—
	460-60	—	—	—	—	—	—	—	—	—	—	—	—
	575-60	—	—	—	—	—	—	—	—	—	—	—	—
030	208/230-60	—	—	—	—	—	—	—	—	—	—	—	—
	380-60	—	—	—	—	—	—	—	—	—	—	—	—
	460-60	—	—	—	—	—	—	—	—	—	—	—	—
	575-60	—	—	—	—	—	—	—	—	—	—	—	—
035	208/230-60	185.7	200	379.9	200	—	—	—	—	—	—	—	—
	380-60	113.9	125	229.3	125	—	—	—	—	—	—	—	—
	460-60	92.3	110	194.9	100	—	—	—	—	—	—	—	—
	575-60	73.7	80	135.8	80	—	—	—	—	—	—	—	—
040	208/230-60	218.1	250	415.3	250	—	—	—	—	—	—	—	—
	380-60	122.9	125	238.2	125	—	—	—	—	—	—	—	—
	460-60	96.3	110	198.7	110	—	—	—	—	—	—	—	—
	575-60	76.5	90	158.5	90	—	—	—	—	—	—	—	—
045	208/230-60	249.9	300	489.0	300	—	—	—	—	—	—	—	—
	380-60	130.0	150	238.6	150	—	—	—	—	—	—	—	—
	460-60	107.8	125	233.4	125	—	—	—	—	—	—	—	—
	575-60	89.0	100	178.3	100	—	—	—	—	—	—	—	—
050	208/230-60	256.3	300	492.2	300	262.8	300	498.7	300	—	—	—	—
	380-60	136.4	150	241.8	150	140.0	150	245.4	150	—	—	—	—
	460-60	116.8	125	237.9	125	119.6	125	240.7	125	—	—	—	—
	575-60	99.4	110	183.5	110	101.6	110	185.7	110	—	—	—	—
055	208/230-60	273.1	300	547.8	300	279.6	300	554.3	300	—	—	—	—
	380-60	156.3	175	316.9	175	159.9	175	320.5	175	—	—	—	—
	460-60	128.6	150	277.8	150	131.4	150	280.6	150	—	—	—	—
	575-60	110.5	125	216.7	125	112.7	125	218.9	125	—	—	—	—
060	208/230-60	282.1	300	552.3	300	288.6	300	558.8	300	—	—	—	—
	380-60	170.5	200	324.0	200	174.1	200	327.6	200	—	—	—	—
	460-60	136.2	150	281.6	150	139.0	150	284.4	150	—	—	—	—
	575-60	118.1	125	220.5	125	120.3	125	222.7	125	—	—	—	—

LEGEND

- ICF** — Instantaneous Current Flow
- MCA** — Minimum Circuit Amps
- MOCP** — Maximum Overcurrent Protection

- 3. Cooler heater is wired into the control circuit so it is always operable as long as the power supply disconnect and heater safety device are on.
- 4. 30RAP chillers with Greenspeed intelligence are not available on unit sizes 070-150.

NOTES:

- 1. Units are suitable for use on electrical systems where voltage supplied to the unit terminals is not below or above the listed minimum and maximum limits. Maximum allowable phase imbalance is: voltage 2%; amps 10%.
- 2. All units/modules have single point primary power connection. (Each unit/module requires its own power supply.) Main power must be supplied from a field-supplied disconnect.



Table 25 — 30RAP Electrical Data — Single Point, Hydronic Package with Optional Value Sound Fans (60 Hz Only) (cont)

30RAP UNIT SIZE	VOLTAGE V-Hz (3 Ph)	PUMP SIZE 1.5 hp				PUMP SIZE 3.0 hp				PUMP SIZE 5.0 hp			
		MCA	MOCP	ICF	REC FUSE	MCA	MOCP	ICF	REC FUSE	MCA	MOCP	ICF	REC FUSE
070	208/230-60	—	—	—	—	—	—	—	—	—	—	—	—
	380-60	—	—	—	—	—	—	—	—	—	—	—	—
	460-60	—	—	—	—	—	—	—	—	—	—	—	—
	575-60	—	—	—	—	—	—	—	—	—	—	—	—
080	208/230-60	—	—	—	—	—	—	—	—	—	—	—	—
	380-60	—	—	—	—	—	—	—	—	—	—	—	—
	460-60	—	—	—	—	—	—	—	—	—	—	—	—
	575-60	—	—	—	—	—	—	—	—	—	—	—	—
090	208/230-60	—	—	—	—	—	—	—	—	—	—	—	—
	380-60	—	—	—	—	—	—	—	—	—	—	—	—
	460-60	—	—	—	—	—	—	—	—	—	—	—	—
	575-60	—	—	—	—	—	—	—	—	—	—	—	—
100	208/230-60	—	—	—	—	—	—	—	—	—	—	—	—
	380-60	—	—	—	—	—	—	—	—	—	—	—	—
	460-60	—	—	—	—	—	—	—	—	—	—	—	—
	575-60	—	—	—	—	—	—	—	—	—	—	—	—
115	208/230-60	—	—	—	—	—	—	—	—	—	—	—	—
	380-60	—	—	—	—	—	—	—	—	—	—	—	—
	460-60	—	—	—	—	—	—	—	—	—	—	—	—
	575-60	—	—	—	—	—	—	—	—	—	—	—	—
130	208/230-60	—	—	—	—	—	—	—	—	—	—	—	—
	380-60	—	—	—	—	—	—	—	—	—	—	—	—
	460-60	—	—	—	—	—	—	—	—	—	—	—	—
	575-60	—	—	—	—	—	—	—	—	—	—	—	—
150	208/230-60	—	—	—	—	—	—	—	—	670.2	700	1112.4	700
	380-60	—	—	—	—	—	—	—	—	355.2	400	608.6	400
	460-60	—	—	—	—	—	—	—	—	300.1	350	508.1	350
	575-60	—	—	—	—	—	—	—	—	243.3	250	410.9	250

30RAP UNIT SIZE	VOLTAGE V-Hz (3 Ph)	PUMP SIZE 7.5 hp				PUMP SIZE 10.0 hp				PUMP SIZE 15.0 hp			
		MCA	MOCP	ICF	REC FUSE	MCA	MOCP	ICF	REC FUSE	MCA	MOCP	ICF	REC FUSE
070	208/230-60	344.5	400	614.7	400	351.0	400	621.2	400	—	—	—	—
	380-60	208.4	225	361.9	225	212.0	225	365.5	225	—	—	—	—
	460-60	166.4	175	311.8	175	169.2	175	314.6	175	—	—	—	—
	575-60	144.4	150	246.8	150	146.6	150	249.0	150	—	—	—	—
080	208/230-60	393.4	400	663.6	400	399.9	450	670.1	450	411.6	450	681.8	450
	380-60	225.0	250	378.5	250	228.6	250	382.1	250	235.6	250	389.1	250
	460-60	185.2	200	330.6	200	188.0	200	333.4	200	193.5	200	338.9	200
	575-60	159.3	175	261.7	175	161.5	175	263.9	175	166.3	175	268.7	175
090	208/230-60	406.9	450	677.1	450	413.4	450	683.6	450	425.1	450	695.3	450
	380-60	246.3	250	399.8	250	249.9	250	403.4	250	256.9	300	410.4	300
	460-60	196.6	200	342.0	200	199.4	225	344.8	225	204.9	225	350.3	225
	575-60	170.7	175	273.1	175	172.9	175	275.3	175	177.7	200	280.1	200
100	208/230-60	482.5	500	924.7	500	489.0	500	931.2	500	500.7	600	942.9	600
	380-60	252.9	300	506.3	300	256.5	300	509.9	300	263.5	300	516.9	300
	460-60	214.6	250	422.6	250	217.4	250	425.4	250	222.9	250	430.9	250
	575-60	172.4	200	340.0	200	174.6	200	342.2	200	179.4	200	347.0	200
115	208/230-60	540.1	600	931.3	600	546.6	600	937.8	600	558.3	600	949.5	600
	380-60	281.6	300	493.6	300	285.2	300	497.2	300	292.2	300	504.2	300
	460-60	239.5	250	413.6	250	242.3	250	416.4	250	247.8	250	421.9	250
	575-60	191.6	200	333.8	200	193.8	200	336.0	200	198.6	200	340.8	200
130	208/230-60	609.1	700	1051.3	700	615.6	700	1057.8	700	627.3	700	1069.5	700
	380-60	320.9	350	574.3	350	324.5	350	577.9	350	331.5	350	584.9	350
	460-60	271.7	300	479.7	300	274.5	300	482.5	300	280.0	300	488.0	300
	575-60	219.2	250	386.8	250	221.4	250	389.0	250	226.2	250	393.8	250
150 Dual Pump	208/230-60	673.3	700	1115.5	700	679.8	700	1122.0	700	691.5	700	1133.7	700
	380-60	357.5	400	610.9	400	361.1	400	614.5	400	368.1	400	621.5	400
	460-60	301.7	350	509.7	350	304.5	350	512.5	350	310.0	350	518.0	350
	575-60	244.9	250	412.5	250	247.1	250	414.7	250	251.9	300	419.5	300
150 Single Pump	208/230-60	676.8	700	1119.0	700	679.8	700	1122.0	700	691.5	700	1133.7	700
	380-60	359.4	400	612.8	400	361.1	400	614.5	400	368.1	400	621.5	400
	460-60	303.1	300	511.1	350	304.5	350	512.5	350	310.0	350	518.0	350
	575-60	246.0	250	413.6	250	247.1	250	414.7	250	251.9	300	419.5	300

LEGEND

- ICF — Instantaneous Current Flow
- MCA — Minimum Circuit Amps
- MOCP — Maximum Overcurrent Protection

NOTES:

1. Units are suitable for use on electrical systems where voltage supplied to the unit terminals is not below or above the listed minimum and maximum limits. Maximum allowable phase imbalance is: voltage 2%; amps 10%.
2. All units/modules have single point primary power connection. (Each unit/module requires its own power supply.) Main power must be supplied from a field-supplied disconnect.

3. Cooler heater is wired into the control circuit so it is always operable as long as the power supply disconnect and heater safety device are on.
4. 30RAP chillers with Greenspeed intelligence are not available on unit sizes 070-150.



Table 26 — 30RAP Electrical Data — Dual Point, Hydronic Package with Optional Value Sound Fans (60 Hz Only)

30RAP UNIT SIZE	VOLTAGE V-Ph-Hz	PUMP SIZE 5.0 hp, CIRCUIT 1				PUMP SIZE 5.0 hp, CIRCUIT 2			
		MCA	MOCP	ICF	REC FUSE	MCA	MOCP	ICF	REC FUSE
150	208/230-3-60	372.2	450	814.4	400	321.6	400	763.8	350
	380-3-60	199.2	225	452.6	225	168.3	200	421.7	200
	460-3-60	168.2	200	376.2	200	142.3	175	350.3	175
	575-3-60	136.2	150	303.8	150	115.6	125	283.2	125
30RAP UNIT SIZE	VOLTAGE V-Ph-Hz	PUMP SIZE 7.5 hp, CIRCUIT 1				PUMP SIZE 7.5 hp, CIRCUIT 2			
		MCA	MOCP	ICF	REC FUSE	MCA	MOCP	ICF	REC FUSE
070	208/230-3-60	158.6	200	428.8	175	199.9	250	470.1	225
	380-3-60	96.0	125	249.5	110	120.9	150	274.4	150
	460-3-60	77.0	100	222.4	90	96.1	110	241.5	110
	575-3-60	66.3	90	168.7	80	84.0	100	186.4	90
080	208/230-3-60	206.3	250	442.2	225	199.9	250	470.1	225
	380-3-60	110.8	125	216.2	125	120.9	150	274.4	150
	460-3-60	94.9	110	216.0	110	96.1	110	241.5	110
	575-3-60	80.3	100	164.4	90	84.0	100	186.4	90
090	208/230-3-60	221.0	250	491.2	250	199.9	250	470.1	225
	380-3-60	133.9	150	287.4	150	120.9	150	274.4	150
	460-3-60	107.2	125	252.6	125	96.1	110	241.5	110
	575-3-60	92.6	110	195.0	100	84.0	100	186.4	90
100	208/230-3-60	239.0	300	681.2	300	262.3	300	653.5	300
	380-3-60	127.3	175	380.7	150	135.2	150	347.2	150
	460-3-60	107.8	125	315.8	125	115.0	125	289.1	125
	575-3-60	86.8	110	254.4	100	92.2	110	234.4	100
115	208/230-3-60	296.6	350	687.8	350	262.3	300	653.5	300
	380-3-60	156.0	175	368.0	175	135.2	150	347.2	150
	460-3-60	132.7	150	306.8	150	115.0	125	289.1	125
	575-3-60	106.0	125	248.2	125	92.2	110	234.4	100
130	208/230-3-60	303.2	350	694.4	350	324.7	400	766.9	350
	380-3-60	159.9	175	371.9	175	170.6	200	424.0	200
	460-3-60	136.0	150	310.1	150	143.9	175	351.9	175
	575-3-60	108.6	125	250.8	125	117.2	150	284.8	150
150 Dual Pump	208/230-3-60	372.2	450	814.4	400	324.7	400	766.9	350
	380-3-60	199.2	225	452.6	225	170.6	200	424.0	200
	460-3-60	168.2	200	376.2	200	143.9	175	351.9	175
	575-3-60	136.2	150	303.8	150	117.2	150	284.8	150
150 Single Pump	208/230-3-60	372.2	450	814.4	400	328.2	400	770.4	400
	380-3-60	199.2	225	452.6	225	172.5	200	425.9	200
	460-3-60	168.2	200	376.2	200	145.3	175	353.3	175
	575-3-60	136.2	150	303.8	150	118.3	150	285.9	150

LEGEND

- ICF — Instantaneous Current Flow
- MCA — Minimum Circuit Amps
- MOCP — Maximum Overcurrent Protection

NOTES:

1. Units are suitable for use on electrical systems where voltage supplied to the unit terminals is not below or above the listed minimum and maximum limits. Maximum allowable phase imbalance is: voltage 2%; amps 10%.
2. All units/modules have dual point primary power connection. (Each unit/module requires its own power supply.) Main power must be supplied from a field-supplied disconnect.

3. Cooler heater is wired into the control circuit so it is always operable as long as the power supply disconnect is on, even if any safety device is open.
4. 30RAP chillers with Greenspeed® intelligence are not available on unit sizes 070-150.



Table 26 — 30RAP Electrical Data — Dual Point, Hydronic Package with Optional Value Sound Fans (60 Hz Only) (cont)

30RAP UNIT SIZE	VOLTAGE V-Ph-Hz	PUMP SIZE 10.0 HP CIRCUIT 1				PUMP SIZE 10.0 HP CIRCUIT 2			
		MCA	MOCP	ICF	REC FUSE	MCA	MOCP	ICF	REC FUSE
070	208/230-3-60	158.6	200	428.8	175	206.4	250	476.6	225
	380-3-60	96.0	125	249.5	110	124.5	150	278.0	150
	460-3-60	77.0	100	222.4	90	98.9	125	244.3	110
	575-3-60	66.3	90	168.7	80	86.2	100	188.6	100
080	208/230-3-60	206.3	250	442.2	225	206.4	250	476.6	225
	380-3-60	110.8	125	216.2	125	124.5	150	278.0	150
	460-3-60	94.9	110	216.0	110	98.9	125	244.3	110
	575-3-60	80.3	100	164.4	90	86.2	100	188.6	100
090	208/230-3-60	221.0	250	491.2	250	206.4	250	476.6	225
	380-3-60	133.9	150	287.4	150	124.5	150	278.0	150
	460-3-60	107.2	125	252.6	125	98.9	125	244.3	110
	575-3-60	92.6	110	195.0	100	86.2	100	188.6	100
100	208/230-3-60	239.0	300	681.2	300	268.8	300	660.0	300
	380-3-60	127.3	175	380.7	150	138.8	175	350.8	150
	460-3-60	107.8	125	315.8	125	117.8	150	291.9	150
	575-3-60	86.8	110	254.4	100	94.4	110	236.6	110
115	208/230-3-60	296.6	350	687.8	350	268.8	300	660.0	300
	380-3-60	156.0	175	368.0	175	138.8	175	350.8	150
	460-3-60	132.7	150	306.8	150	117.8	150	291.9	150
	575-3-60	106.0	125	248.2	125	94.4	110	236.6	110
130	208/230-3-60	303.2	350	694.4	350	331.2	400	773.4	400
	380-3-60	159.9	175	371.9	175	174.2	225	427.6	200
	460-3-60	136.0	150	310.1	150	146.7	175	354.7	175
	575-3-60	108.6	125	250.8	125	119.4	150	287.0	150
150	208/230-3-60	372.2	450	814.4	400	331.2	400	773.4	400
	380-3-60	199.2	225	452.6	225	174.2	225	427.6	200
	460-3-60	168.2	200	376.2	200	146.7	175	354.7	175
	575-3-60	136.2	150	303.8	150	119.4	150	287.0	150

30RAP UNIT SIZE	VOLTAGE V-Ph-Hz	PUMP SIZE 15.0 HP CIRCUIT 1				PUMP SIZE 15.0 HP CIRCUIT 2			
		MCA	MOCP	ICF	REC FUSE	MCA	MOCP	ICF	REC FUSE
070	208/230-3-60	—	—	—	—	—	—	—	—
	380-3-60	—	—	—	—	—	—	—	—
	460-3-60	—	—	—	—	—	—	—	—
	575-3-60	—	—	—	—	—	—	—	—
080	208/230-3-60	206.3	250	442.2	225	218.1	250	488.3	250
	380-3-60	110.8	125	216.2	125	131.5	150	285.0	150
	460-3-60	94.9	110	216.0	110	104.4	125	249.8	125
	575-3-60	80.3	100	164.4	90	91.0	110	193.4	100
090	208/230-3-60	221.0	250	491.2	250	218.1	250	488.3	250
	380-3-60	133.9	150	287.4	150	131.5	150	285.0	150
	460-3-60	107.2	125	252.6	125	104.4	125	249.8	125
	575-3-60	92.6	110	195.0	100	91.0	110	193.4	100
100	208/230-3-60	239.0	300	681.2	300	280.5	350	671.7	300
	380-3-60	127.3	175	380.7	150	145.8	175	357.8	175
	460-3-60	107.8	125	315.8	125	123.3	150	297.4	150
	575-3-60	86.8	110	254.4	100	99.2	125	241.4	110
115	208/230-3-60	296.6	350	687.8	350	280.5	350	671.7	300
	380-3-60	156.0	175	368.0	175	145.8	175	357.8	175
	460-3-60	132.7	150	306.8	150	123.3	150	297.4	150
	575-3-60	106.0	125	248.2	125	99.2	125	241.4	110
130	208/230-3-60	303.2	350	694.4	350	342.9	400	785.1	400
	380-3-60	159.9	175	371.9	175	181.2	225	434.6	200
	460-3-60	136.0	150	310.1	150	152.2	175	360.2	175
	575-3-60	108.6	125	250.8	125	124.2	150	291.8	150
150	208/230-3-60	372.2	450	814.4	400	342.9	400	785.1	400
	380-3-60	199.2	225	452.6	225	181.2	225	434.6	200
	460-3-60	168.2	200	376.2	200	152.2	175	360.2	175
	575-3-60	136.2	150	303.8	150	124.2	150	291.8	150

LEGEND

- ICF** — Instantaneous Current Flow
- MCA** — Minimum Circuit Amps
- MOCP** — Maximum Overcurrent Protection

NOTES:

1. Units are suitable for use on electrical systems where voltage supplied to the unit terminals is not below or above the listed minimum and maximum limits. Maximum allowable phase imbalance is: voltage 2%; amps 10%.
2. All units/modules have dual point primary power connection. (Each unit/module requires its own power supply.) Main power must be supplied from a field-supplied disconnect.

3. Cooler heater is wired into the control circuit so it is always operable as long as the power supply disconnect is on, even if any safety device is open.
4. 30RAP chillers with Greenspeed® intelligence are not available on unit sizes 070-150.



Table 27 — Fan Electrical Data — Single Point, Standard Low-Sound Aeroacoustic™ Fans Unit Sizes 011-060

UNIT 30RAP	UNIT VOLTAGE V-Hz (3 Ph)	STANDARD CONDENSER FANS	
		Quantity	FLA (each)
011	208/230-60	1	6.0
	380-60	1	3.9
	380/415-50	1	2.9
	460-60	1	2.9
	575-60	1	2.4
016	208/230-60	1	6.0
	380-60	1	3.9
	380/415-50	1	2.9
	460-60	1	2.9
	575-60	1	2.4
018	208/230-60	2	6.0
	380-60	2	3.9
	380/415-50	2	2.9
	460-60	2	2.9
	575-60	2	2.4
020	208/230-60	2	6.0
	380-60	2	3.9
	380/415-50	2	2.9
	460-60	2	2.9
	575-60	2	2.4
025	208/230-60	2	6.0
	380-60	2	3.9
	380/415-50	2	2.9
	460-60	2	2.9
	575-60	2	2.4
030	208/230-60	2	6.0
	380-60	2	3.9
	380/415-50	2	2.9
	460-60	2	2.9
	575-60	2	2.4
035	208/230-60	3	6.0
	380-60	3	3.9
	380/415-50	3	2.9
	460-60	3	2.9
	575-60	3	2.4
040	208/230-60	3	6.0
	380-60	3	3.9
	380/415-50	3	2.9
	460-60	3	2.9
	575-60	3	2.4
045	208/230-60	3	6.0
	380-60	3	3.9
	380/415-50	3	2.9
	460-60	3	2.9
	575-60	3	2.4
050	208/230-60	3	6.0
	380-60	3	3.9
	380/415-50	3	2.9
	460-60	3	2.9
	575-60	3	2.4
055	208/230-60	4	6.0
	380-60	4	3.9
	380/415-50	4	2.9
	460-60	4	2.9
	575-60	4	2.4
060	208/230-60	4	6.0
	380-60	4	3.9
	380/415-50	4	2.9
	460-60	4	2.9
	575-60	4	2.4

LEGEND

FLA — Full Load Amps

NOTES:

1. Units are suitable for use on electrical systems where voltage supplied to the unit terminals is not below or above the listed minimum and maximum limits. Maximum allowable phase imbalance is: voltage 2%; amps 10%.
2. All units/modules have single point primary power connection. (Each unit/module requires its own power supply.) Main power must be supplied from a field-supplied disconnect.
3. The unit control circuit power transformer (24 v, single-phase for all voltages) is factory supplied.
4. Cooler heater is wired into the control circuit so it is always operable as long as the power supply disconnect and heater safety device are on.
5. 30RAP chillers with Greenspeed intelligence are not available on unit sizes 070-150.

Table 28 — Fan Electrical Data — Single Point, Standard Low-Sound Aeroacoustic™ Fans Unit Sizes 070-150

UNIT 30RAP	UNIT VOLTAGE V-Hz (3 Ph)	STANDARD CONDENSER FANS	
		Quantity	FLA (each)
070	208/230-60	5	6.0
	380-60	5	3.9
	380/415-50	5	2.9
	460-60	5	2.9
	575-60	5	2.4
080	208/230-60	6	6.0
	380-60	6	3.9
	380/415-50	6	2.9
	460-60	6	2.9
	575-60	6	2.4
090	208/230-60	6	6.0
	380-60	6	3.9
	380/415-50	6	2.9
	460-60	6	2.9
	575-60	6	2.4
100	208/230-60	7	6.0
	380-60	7	3.9
	380/415-50	7	2.9
	460-60	7	2.9
	575-60	7	2.4
115	208/230-60	8	6.0
	380-60	8	3.9
	380/415-50	8	2.9
	460-60	8	2.9
	575-60	8	2.4
130	208/230-60	9	6.0
	380-60	9	3.9
	380/415-50	9	2.9
	460-60	9	2.9
	575-60	9	2.4
150	208/230-60	10	6.0
	380-60	10	3.9
	380/415-50	10	2.9
	460-60	10	2.9
	575-60	10	2.4

LEGEND

FLA — Full Load Amps

NOTES:

1. Units are suitable for use on electrical systems where voltage supplied to the unit terminals is not below or above the listed minimum and maximum limits. Maximum allowable phase imbalance is: voltage 2%; amps 10%.
2. All units/modules have single point primary power connection. (Each unit/module requires its own power supply.) Main power must be supplied from a field-supplied disconnect.
3. The unit control circuit power transformer (24 v, single-phase for all voltages) is factory supplied.
4. Cooler heater is wired into the control circuit so it is always operable as long as the power supply disconnect and heater safety device are on.
5. 30RAP chillers with Greenspeed® intelligence are not available on unit sizes 070-150.

**Table 29 — Fan Electrical Data — Single Point, Optional Value Sound Fans
Unit Sizes 011-060**

UNIT 30RAP	UNIT VOLTAGE V-Hz (3 Ph)	OPTIONAL CONDENSER FANS	
		Quantity	FLA (each)
011	208/230-60	1	6.6
	380-60	1	3.9
	380/415-50	1	3.3
	460-60	1	3.3
	575-60	1	2.6
016	208/230-60	1	6.6
	380-60	1	3.9
	380/415-50	1	3.3
	460-60	1	3.3
	575-60	1	2.6
018	208/230-60	2	6.6
	380-60	2	3.9
	380/415-50	2	3.3
	460-60	2	3.3
	575-60	2	2.6
020	208/230-60	2	6.6
	380-60	2	3.9
	380/415-50	2	3.3
	460-60	2	3.3
	575-60	2	2.6
025	208/230-60	2	6.6
	380-60	2	3.9
	380/415-50	2	3.3
	460-60	2	3.3
	575-60	2	2.6
030	208/230-60	2	6.6
	380-60	2	3.9
	380/415-50	2	3.3
	460-60	2	3.3
	575-60	2	2.6
035	208/230-60	3	6.6
	380-60	3	3.9
	380/415-50	3	3.3
	460-60	3	3.3
	575-60	3	2.6
040	208/230-60	3	6.6
	380-60	3	3.9
	380/415-50	3	3.3
	460-60	3	3.3
	575-60	3	2.6
045	208/230-60	3	6.6
	380-60	3	3.9
	380/415-50	3	3.3
	460-60	3	3.3
	575-60	3	2.6
050	208/230-60	3	6.6
	380-60	3	3.9
	380/415-50	3	3.3
	460-60	3	3.3
	575-60	3	2.6
055	208/230-60	4	6.6
	380-60	4	3.9
	380/415-50	4	3.3
	460-60	4	3.3
	575-60	4	2.6
060	208/230-60	4	6.6
	380-60	4	3.9
	380/415-50	4	3.3
	460-60	4	3.3
	575-60	4	2.6

LEGEND

FLA — Full Load Amps

NOTES:

1. Units are suitable for use on electrical systems where voltage supplied to the unit terminals is not below or above the listed minimum and maximum limits. Maximum allowable phase imbalance is: voltage 2%; amps 10%.
2. All units/modules have single point primary power connection. (Each unit/module requires its own power supply.) Main power must be supplied from a field-supplied disconnect.
3. The unit control circuit power transformer (24 v, single-phase for all voltages) is factory supplied.
4. Cooler heater is wired into the control circuit so it is always operable as long as the power supply disconnect and heater safety device are on.
5. 30RAP chillers with Greenspeed intelligence are not available on unit sizes 070-150.

**Table 30 — Fan Electrical Data — Single Point, Optional Value Sound Fans
Unit Sizes 070-150**

UNIT 30RAP	UNIT VOLTAGE V-Hz (3 Ph)	OPTIONAL CONDENSER FANS	
		Quantity	FLA (each)
070	208/230-60	5	6.6
	380-60	5	3.9
	380/415-50	5	3.3
	460-60	5	3.3
	575-60	5	2.6
080	208/230-60	6	6.6
	380-60	6	3.9
	380/415-50	6	3.3
	460-60	6	3.3
	575-60	6	2.6
090	208/230-60	6	6.6
	380-60	6	3.9
	380/415-50	6	3.3
	460-60	6	3.3
	575-60	6	2.6
100	208/230-60	7	6.6
	380-60	7	3.9
	380/415-50	7	3.3
	460-60	7	3.3
	575-60	7	2.6
115	208/230-60	8	6.6
	380-60	8	3.9
	380/415-50	8	3.3
	460-60	8	3.3
	575-60	8	2.6
130	208/230-60	9	6.6
	380-60	9	3.9
	380/415-50	9	3.3
	460-60	9	3.3
	575-60	9	2.6
150	208/230-60	10	6.6
	380-60	10	3.9
	380/415-50	10	3.3
	460-60	10	3.3
	575-60	10	2.6

LEGEND

FLA — Full Load Amps

NOTES:

1. Units are suitable for use on electrical systems where voltage supplied to the unit terminals is not below or above the listed minimum and maximum limits. Maximum allowable phase imbalance is: voltage 2%; amps 10%.
2. All units/modules have single point primary power connection. (Each unit/module requires its own power supply.) Main power must be supplied from a field-supplied disconnect.
3. The unit control circuit power transformer (24 v, single-phase for all voltages) is factory supplied.
4. Cooler heater is wired into the control circuit so it is always operable as long as the power supply disconnect and heater safety device are on.
5. 30RAP chillers with Greenspeed® intelligence are not available on unit sizes 070-150.

Table 31 — Pump Electrical Data (60 Hz Only)

30RAP SIZE	PUMP OPTION	PUMP SIZE	PUMP RPM	UNIT VOLTAGE V-Hz (3 Ph)	FLA (each)
011-060	2, 9	1.5 HP	3500	208/230-60	4.3
			3500	380-60	2.4
			3500	460-60	2.1
			3500	575-60	1.6
	3, 4, B, C	3.0 HP	3500	208/230-60	7.9
			3500	380-60	4.4
			3500	460-60	3.7
			3500	575-60	3.0
	5, 6, D, F	5.0 HP	3500	208/230-60	12.6
			3500	380-60	7.0
			3500	460-60	5.8
			3500	575-60	4.6
	7, G	7.5 HP	3500	208/230-60	18.5
			3500	380-60	10.4
			3500	460-60	8.7
			3500	575-60	7.0
	Z, H	10.0 HP	3500	208/230-60	25.0
			3500	380-60	14.0
			3500	460-60	11.5
			3500	575-60	9.2
070-150	2, D	5.0 HP	1750	208/230-60	15.4
				380-60	8.1
				460-60	7.1
				575-60	5.4
	3, 8, F, L	7.5 HP	1750 - 150 ton single	208/230-60	22.0
				380-60	12.3
			3500 - All other	460-60	10.1
				575-60	8.1
	4, 9, G, M	10.0 HP	3500	208/230-60	18.5
				380-60	10.4
460-60				8.7	
575-60				7.0	
5, B, H, N	15.0 HP	3500	208/230-60	25.0	
			380-60	14.0	
			460-60	11.5	
			575-60	9.2	
			208/230-60	36.7	
			380-60	21.0	
			460-60	17.0	
			575-60	14.0	

LEGEND

FLA — Full Load Amps

NOTES:

- Units are suitable for use on electrical systems where voltage supplied to the unit terminals is not below or above the listed minimum and maximum limits. Maximum allowable phase imbalance is: voltage 2%; amps 10%.

- All units/modules have single point primary power connection. (Each unit/module requires its own power supply.) Main power must be supplied from a field-supplied disconnect.
- The unit control circuit power transformer (24 v, single-phase for all voltages) is factory supplied.
- Cooler heater is wired into the control circuit so it is always operable as long as the power supply disconnect and heater safety device are on.
- 30RAP chillers with Greenspeed intelligence are not available on unit sizes 070-150.

Table 32 — Accessory Tank Electrical Data (011-060 sizes only)

UNIT VOLTAGE (V-Hz)	ACCESSORY PART NO. 30RA-900---	FLA
208/230-60	050	11.3
	051	11.3
	052	22.6
460-60	050	5.7
	051	5.7
	052	11.3
575-60	050	7.1
	051	7.1
	052	14.1
380-60	050	4.7
	051	4.7
	052	9.3
380/415-50	050	4.9
	051	4.9
	052	9.8

LEGEND

FLA — Full Load Amps

NOTE: The storage tank obtains its power from the chiller. No separate power source is required.

Table 33 — Compressor Electrical Data, Single/Dual Point, Unit Sizes 011-060

UNIT 30RAP	NUMBER OF COMPRESSORS PER CIRCUIT	UNIT VOLTAGE V-Hz (3 Ph)	CIRCUIT*			
			CIRCUIT A		CIRCUIT B	
			RLA	LRA	RLA	LRA
011	2	208/230-60	23.2 / 16.0	164 / 110	—	—
		380-60	12.2 / 8.5	73 / 66	—	—
		380/415-50	11.2 / 7.8	75 / 52	—	—
		460-60	11.2 / 7.8	75 / 52	—	—
		575-60	7.9 / 5.7	54 / 39	—	—
016	2	208/230-60	28.2 / 23.2	240 / 164	—	—
		380-60	16.0 / 12.2	135 / 73	—	—
		380/415-50	14.7 / 11.2	130 / 75	—	—
		460-60	14.7 / 11.2	130 / 75	—	—
		575-60	11.3 / 7.9	94 / 54	—	—
018	2	208/230-60	33.4	225	—	—
		380-60	19.2	140	—	—
		380/415-50	16.7	114	—	—
		460-60	16.7	114	—	—
		575-60	13.4	80	—	—
020	2	208/230-60	35.8	239	—	—
		380-60	23.7	145	—	—
		380/415-50	17.9	125	—	—
		460-60	17.9	125	—	—
		575-60	14.3	80	—	—
025	2	208/230-60	51.3	300	—	—
		380-60	26.9	139	—	—
		380/415-50	23.1	150	—	—
		460-60	23.1	150	—	—
		575-60	19.9	109	—	—
030	2	208/230-60	55.8	340	—	—
		380-60	34.0	196	—	—
		380/415-50	26.9	179	—	—
		460-60	26.9	179	—	—
		575-60	23.7	132	—	—
035	2	208/230-60	35.8	239	33.4	225
		380-60	23.7	145	19.2	140
		380/415-50	17.9	125	16.7	114
		460-60	17.9	125	16.7	114
		575-60	14.3	80	13.4	80
040	2	208/230-60	35.8	239	48.1	245
		380-60	23.7	145	23.7	145
		380/415-50	17.9	125	18.6	125
		460-60	17.9	125	18.6	125
		575-60	14.3	80	14.7	100
045	2	208/230-60	48.1	245	51.3	300
		380-60	23.7	145	23.7	145
		380/415-50	18.6	125	23.1	150
		460-60	18.6	125	23.1	150
		575-60	14.7	100	19.9	109
050	2	208/230-60	51.3	300	51.3	300
		380-60	26.9	139	26.9	139
		380/415-50	23.1	150	23.1	150
		460-60	23.1	150	23.1	150
		575-60	19.9	109	19.9	109
055	2	208/230-60	51.3	300	55.8	340
		380-60	26.9	139	34.0	196
		380/415-50	23.1	150	26.9	179
		460-60	23.1	150	26.9	179
		575-60	19.9	109	23.7	132
060	2	208/230-60	55.8	340	55.8	340
		380-60	34.0	196	34.0	196
		380/415-50	26.9	179	26.9	179
		460-60	26.9	179	26.9	179
		575-60	23.7	132	23.7	132

LEGEND

LRA — Locked Rotor Amps
RLA — Rated Load Amps

* All data is per individual compressor. A1/A2 for unit sizes 011 and 016.
 NOTE: 30RAP chillers with Greenspeed® intelligence are not available on unit sizes 070-150.

Table 34 — Compressor Electrical Data, Single/Dual Point, Unit Sizes 070-150

UNIT 30RAP	NUMBER OF COMPRESSORS PER CIRCUIT (A/B)	UNIT VOLTAGE V-Hz (3 Ph)	CIRCUIT*			
			CIRCUIT A		CIRCUIT B	
			RLA	LRA	RLA	LRA
070	2/3	208/230-60	55.8	340	55.8	340
		380-60	34.0	196	34.0	196
		380/415-50	26.9	179	26.9	179
		460-60	26.9	179	26.9	179
		575-60	23.7	132	23.7	132
080	3	208/230-60	51.3	300	55.8	340
		380-60	26.9	139	34.0	196
		380/415-50	23.1	150	26.9	179
		460-60	23.1	150	26.9	179
		575-60	19.9	109	23.7	132
090	3	208/230-60	55.8	340	55.8	340
		380-60	34.0	196	34.0	196
		380/415-50	26.9	179	26.9	179
		460-60	26.9	179	26.9	179
		575-60	23.7	132	23.7	132
100	2/3	208/230-60	75.0 / 94.2	485 / 560	75.0	485.0
		380-60	38.4 / 49.3	260 / 315	38.4	260.0
		380/415-50	32.7 / 41.6	215 / 260	32.7	215.0
		460-60	32.7 / 41.6	215 / 260	32.7	215.0
		575-60	26.2 / 33.9	175 / 210	26.2	175.0
115	3	208/230-60	75.0	485	75.0	485
		380-60	38.4	260	38.4	260
		380/415-50	32.7	215	32.7	215
		460-60	32.7	215	32.7	215
		575-60	26.2	175	26.2	175
130	3	208/230-60	75.0	485	94.2	560
		380-60	38.4	260	49.3	315
		380/415-50	32.7	215	41.6	260
		460-60	32.7	215	41.6	260
		575-60	26.2	175	33.9	210
150	3	208/230-60	94.2	560	94.2	560
		380-60	49.3	315	49.3	315
		380/415-50	32.7	260	41.6	260
		460-60	41.6	260	41.6	260
		575-60	33.9	210	33.9	210

LEGEND

LRA — Locked Rotor Amps
RLA — Rated Load Amps

* All data is per individual compressor. A1/A2 for unit size 100.
 NOTE: 30RAP chillers with Greenspeed intelligence are not available on unit sizes 070-150.

NOTES:

1. FACTORY WIRING IS IN ACCORDANCE WITH UL 1995 STANDARDS. FIELD MODIFICATIONS OR ADDITIONS MUST BE IN COMPLIANCE WITH ALL APPLICABLE CODES.
2. ALL UNITS OR MODULES HAVE SINGLE POINT PRIMARY POWER CONNECTION. MAIN POWER MUST BE SUPPLIED FROM A FIELD OR FACTORY SUPPLIED DISCONNECT.
3. WIRING FOR MAIN FIELD SUPPLY MUST BE RATED 75C. USE COPPER CONDUCTORS ONLY.
 - a. INCOMING WIRE SIZE RANGE FOR TERMINAL BLOCK WITH MCA UP TO 175.1 AMPS IS 14 AWG TO 270 FOR 10-60 TON CHILLERS.
 - b. INCOMING WIRE SIZE RANGE FOR TERMINAL BLOCK WITH MCA FROM 175.1 AMPS TO 420.1 AMPS IS 12 AWG TO 300 FOR 60-150 TON CHILLERS.
 - c. INCOMING WIRE SIZE RANGE FOR TERMINAL BLOCK WITH MCA UP TO 420 AMPS IS 2 AWG TO 600KCMIL FOR 70-150 TON CHILLER.
 - d. INCOMING WIRE SIZE RANGE FOR TERMINAL BLOCK WITH MCA FROM 420.1 AMPS TO 760 AMPS IS 6 AWG TO 500KCMIL (TWO OPENINGS PER POLE) FOR 70-150 TON CHILLERS.
 - e. INCOMING WIRE SIZE RANGE FOR NON-FUSED DISCONNECT WITH MCA UP TO 100 AMPS IS 12 AWG TO 370.
 - f. INCOMING WIRE SIZE RANGE FOR NON-FUSED DISCONNECT WITH MCA FROM 100.1 AMPS TO 250 AMPS IS 6 AWG TO 350 KCMIL.
 - g. INCOMING WIRE SIZE RANGE FOR NON-FUSED DISCONNECT WITH MCA FROM 250.1 TO 600 AMPS IS 370 AWG TO 500KCMIL (TWO OPENINGS PER POLE)
4. REFER TO CERTIFIED DIMENSIONAL DRAWINGS FOR EXACT LOCATIONS OF THE MAIN POWER AND CONTROL POWER ENTRANCE LOCATIONS.
5. TERMINALS 21 AND 25 OF THE LVT ARE FOR CONTROL OF CHILLED WATER PUMP1 (CWP1) STARTER. TERMINALS 21 AND 24 OF THE LVT ARE FOR CONTROL OF CHILLED WATER PUMP2 (CWP2) STARTER. TERMINALS 22 AND 23 OF THE LVT ARE FOR CHILLED WATER PUMP RELAY IS 5 VA SEALED, 10 VA THROUGH AT 24 V. FIELD POWER SUPPLY IS NOT REQUIRED.
6. TERMINALS 18 AND 21 OF LVT ARE FOR AN ALARM RELAY. THE MAXIMUM LOAD ALLOWED FOR THE ALARM RELAY IS 5 VA SEALED, 10 VA THROUGH AT 24V. FIELD POWER SUPPLY IS NOT REQUIRED.
7. MAKE APPROPRIATE CONNECTIONS TO LVT AS SHOWN FOR ENERGY MANAGEMENT BOARD OPTIONS. THE CONTACTS FOR DEMAND LIMIT AND ICE DONE OPTIONS MUST BE RATED FOR DRY CIRCUIT APPLICATION CAPABLE OF HANDLING A 24VAC LOAD UP TO 50 MA. INSTALLATION OF OPTIONAL ENERGY MANAGEMENT BOARD REQUIRED.
8. REMOVE JUMPER BETWEEN TERMINALS 11 AND 17 WHEN FIELD CWP1 IS INSTALLED.
9. TERMINALS 13 & 14 OF TBS ARE FOR FIELD EXTERNAL CONNECTIONS FOR REMOTE ON-OFF. THE CONTACTS MUST BE RATED FOR DRY CIRCUIT APPLICATION CAPABLE OF HANDLING A 24VAC LOAD UP TO 50MA.

LEGEND:

- ALM R - ALARM RELAY (24V), 5 VA MAX
- AWG - AMERICAN WIRE GAUGE
- CWP - CHILLED WATER PUMP
- CWP1 - CHILLED WATER PUMP INTERLOCK
- CWP2 - CHILLED WATER PUMP INTERLOCK
- LVT - LOW VOLTAGE TERMINAL STRIP
- SPT - SPACE TEMPERATURE

- FIELD POWER WIRING
- FACTORY INSTALLED WIRING
- FACTORY INSTALLED OPTION

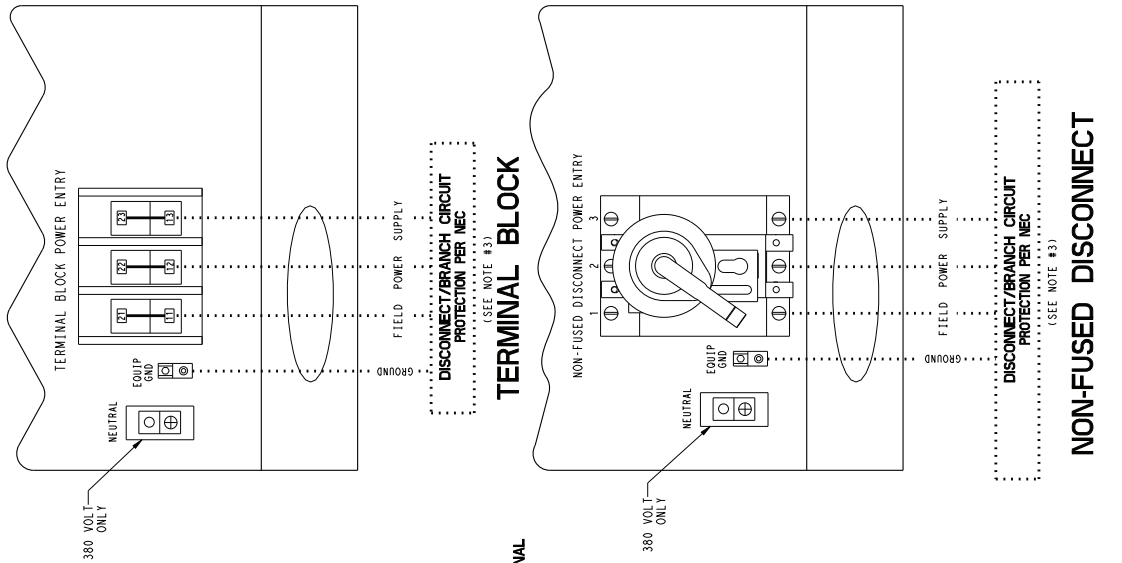

LVT CONTROL WIRING

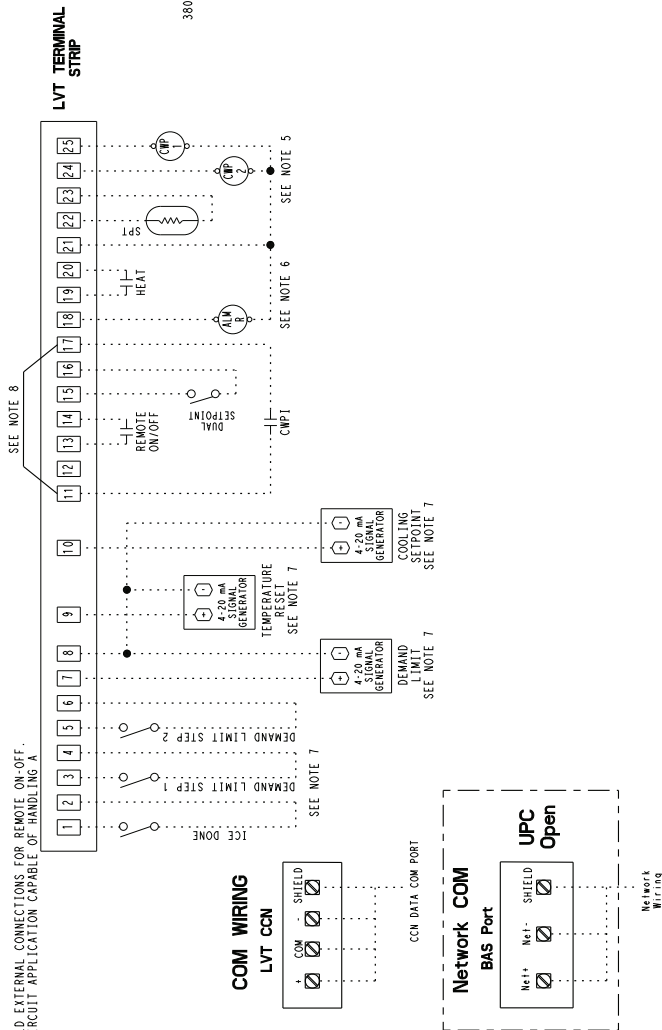

Fig. 36 — Typical Main Power and Control Connections

CONTROL POWER

IMPORTANT: To ensure power to the heaters, make sure auxiliary power to the unit and the compressor circuit breakers is always on (except for servicing or prolonged shutdown). Since water cannot be drained completely, add an appropriate amount of inhibited glycol as noted for winter shutdown.

⚠ CAUTION

Proper rotation of condenser fan(s), pumps and compressors **MUST** be verified. Consult the Controls, Start-Up, Operation, Service, and Troubleshooting manual provided with this chiller for correct procedure. If pump(s) have been removed for trimming, verify that wiring is reconnected in the original manner. Failure to follow these procedures may result in damage to equipment.

Control power is obtained from the main power supply and does **NOT** require a separate source. A toggle switch (marked Emergency On-Off on the unit label diagram and by the switch) allows the control circuit to be manually disconnected when necessary.

IMPORTANT: For 208-v systems, the primary connection tap for all transformers must be changed. The factory default setting is for 230 v. Failure to connect to the proper tap may result in unreliable operation.

Step 6 — Install Accessories

ELECTRICAL — A number of electrical accessories are available to provide the following optional features (for details, refer to the Controls, Start-Up, Operation, Service, and Troubleshooting book):

Energy Management Module (Used for any of the following types of temperature reset, demand limit and ice features):

- 4 to 20 mA leaving fluid temperature reset (requires field-supplied 4 to 20 mA generator)
- 4 to 20 mA cooling set point reset (requires field-supplied 4 to 20 mA generator)
- Discrete inputs for 2-step demand limit (requires field-supplied dry contacts)
- 4 to 20 mA demand limit (requires field-supplied 4 to 20 mA generator)
- Discrete input for Ice Done switch (requires field-supplied dry contacts)

Navigator™ Display — The device provides hand-held, mobile capability using an easy to read 4-line display. The keypad function is the same as the scrolling marquee module. A magnet is provided for “hands free” service of components.

Low Ambient Operation — If outdoor ambient operating temperatures below 45°F (7°C) on size 018-030 units or 32 °F (0°C) on size 035-150 units are expected, refer to separate installation instructions for low ambient operation using accessory Motormaster® V control. The Motormaster low

ambient control option is not available on any unit which employs high-efficiency variable condenser fans (because units with such fans already have low ambient capability).

Minimum Load Accessory — If minimum load accessory is required, refer to unit Price Pages or contact your local Carrier representative for more details. For installation details, refer to separate installation instructions supplied with the accessory package.

Miscellaneous Accessories — For applications requiring special accessories, the following packages are available: external vibration isolation, remote enhanced display, temperature reset, hail guard/security grilles, storage tank, wind baffles, and remote cooler. For installation details, refer to separate installation instructions supplied with these accessory packages.

Step 7 — Check Refrigerant Circuit

LEAK TESTING — Units are shipped with complete operating charge of R-410A (refer to physical data tables) and should be under sufficient pressure to conduct a leak test. Perform a leak test to ensure that leaks have not developed during unit shipment. Dehydration of the system is not required unless the entire refrigerant charge has been lost. Repair any leak found using good refrigeration practice.

DEHYDRATION — Refer to Carrier Standard Service Techniques Manual, Chapter 1, Refrigerants, Sections 6 and 7 for details. *Do not use compressor to evacuate system.*

REFRIGERANT CHARGE (Refer to Tables 6 and 7) — Immediately after the condenser coil in each circuit is a 1/4-in. Schrader connection for charging liquid refrigerant.

Utilization of Novation® heat exchanger technology coils enables the 30RAP chiller to have a very low refrigerant charge. Therefore, if field charging is required, accurately charging to the correct quantity is very important. It is necessary to ensure that the system is completely evacuated before charging and that the refrigerant charge is accurately weighed to within 1% of the nameplate quantity or the unit may not operate correctly.

⚠ CAUTION

When charging, circulate water through the cooler at all times to prevent freezing. Freezing damage is considered abuse and may impair or otherwise negatively affect the Carrier warranty.

⚠ CAUTION

DO NOT OVERCHARGE system. Overcharging results in higher discharge pressure, increased power consumption, and possible compressor damage.

The suction lines are provided with a 1/4-in. Schrader fitting for connecting to low-side system pressure. The location of the suction access port is shown in Fig. 37.

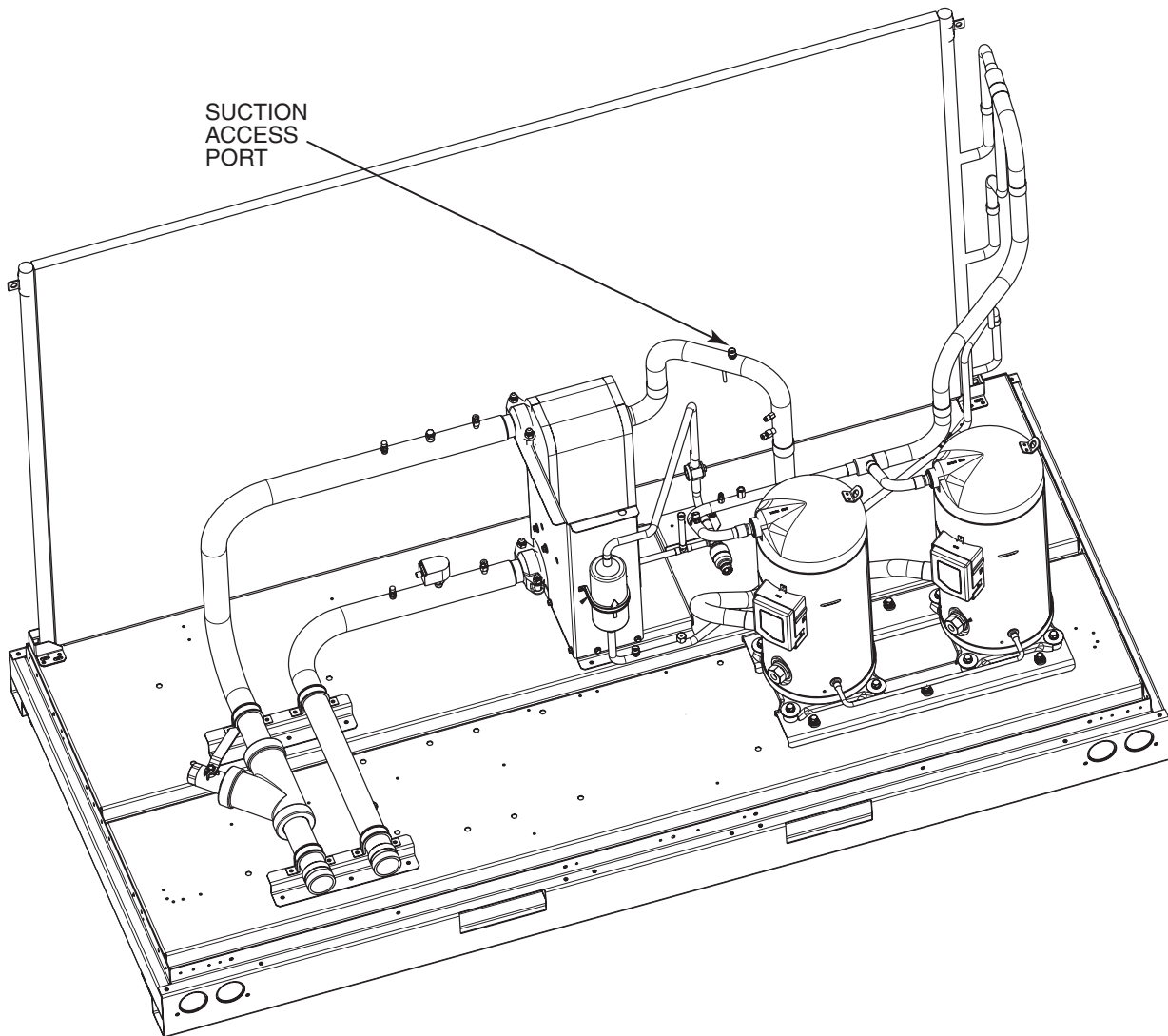

Fig. 37 — Suction Access Port (Sizes 018-030 Shown)

BACnet Communication Option Wiring — The BACnet communication option uses the UPC Open controller. The controller communicates using BACnet on an MS/TP network segment communications at 9600 bps, 19.2 kbps, 38.4 kbps, or 76.8 kbps.

Wire the controllers on an MS/TP network segment in a daisy-chain configuration. Wire specifications for the cable are 22 AWG (American Wire Gauge) or 24 AWG, low-capacitance, twisted, stranded, shielded copper wire. The maximum length is 2000 ft.

Install a BT485 terminator on the first and last controller on a network segment to add bias and prevent signal distortions due to echoing. See Fig. 38-40.

To wire the UPC Open controller to the BAS (Building Automation System) network:

1. Pull the screw terminal connector from the controller's BAS Port.
2. Check the communications wiring for shorts and grounds.
3. Connect the communications wiring to the BAS port's screw terminals labeled Net +, Net -, and Shield.

NOTE: Use the same polarity throughout the network segment.

4. Insert the power screw terminal connector into the UPC Open controller's power terminals if they are not currently connected.
5. Verify communication with the network by viewing a module status report. To perform a module status report using the BACview keypad/display unit, press and hold the "FN" key; then press the "." key.

To install a BT485 terminator, push the BT485 terminator on to the BT485 connector located near the BACnet connector.
NOTE: The BT485 terminator has no polarity associated with it.

To order a BT485 terminator, consult Commercial Products i-Vu® Open Control System Master Prices.

MS/TP WIRING RECOMMENDATIONS — Recommendations are shown in Tables 35 and 36. The wire jacket and UL temperature rating specifications list two acceptable alternatives. The Halar¹ specification has a higher temperature rating and a tougher outer jacket than the SmokeGard² specification, and it is appropriate for use in applications where the user is concerned about abrasion. The Halar jacket is also less likely to crack in extremely low temperatures.

NOTE: Use the specified type of wire and cable for maximum signal integrity.

1. Halar is a registered trademark of Solvay Plastics.
2. SmokeGard is a trademark of AlphaGary-Mexichem Corp.

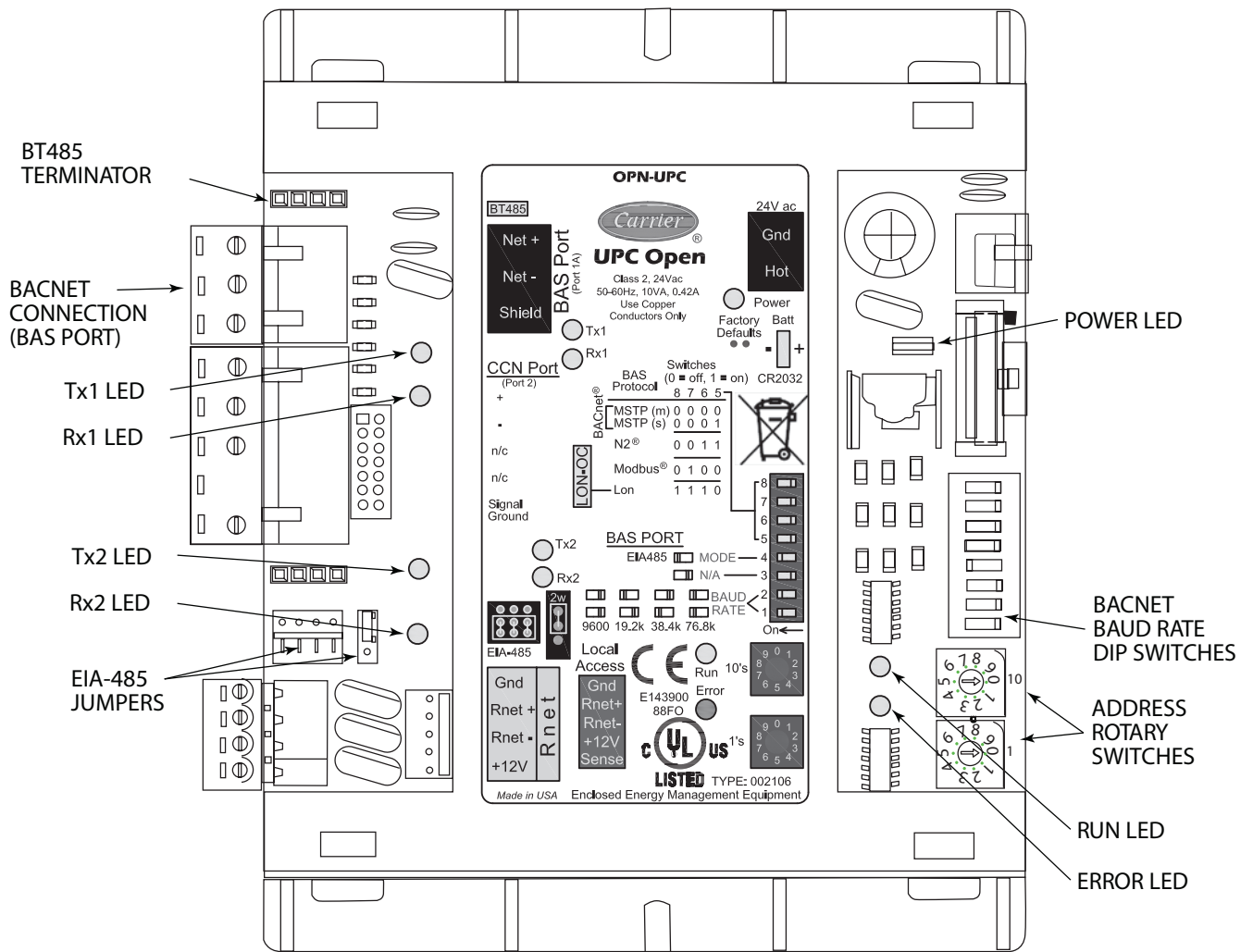

Fig. 38 — UPC Open Controller

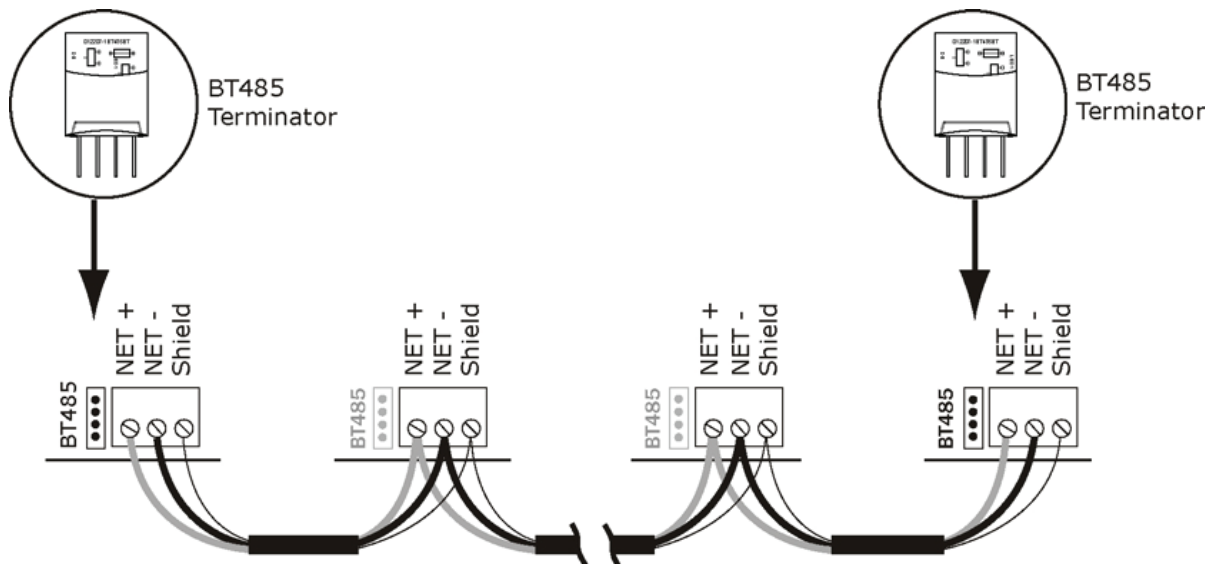

Fig. 39 — Network Wiring

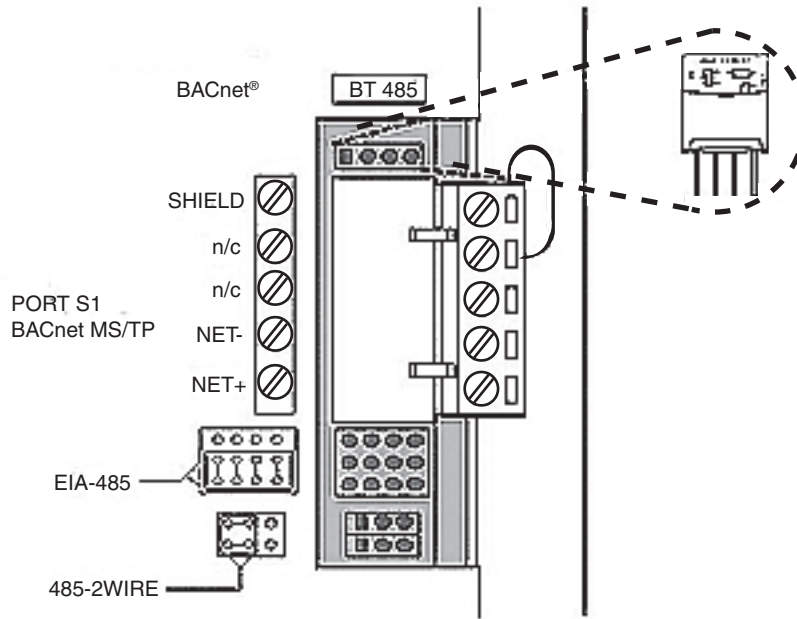

Fig. 40 — BT485 Terminator Installation

Table 35 — MS/TP Wiring Recommendations

SPECIFICATION	RECOMMENDATION
Cable	Single twisted pair, low capacitance, CL2P, 22 AWG (7x30), TC foam FEP, plenum rated cable
Conductor	22 or 24 AWG stranded copper (tin plated)
Insulation	Foamed FEP 0.015 in. (0.381 mm) wall 0.060 in. (1.524 mm) O.D.
Color Code	Black/White
Twist Lay	2 in. (50.8 mm) lay on pair 6 twists/foot (20 twists/meter) nominal
Shielding	Aluminum/Mylar shield with 24 AWG TC drain wire
Jacket	SmokeGard Jacket (SmokeGard PVC) 0.021 in. (0.5334 mm) wall 0.175 in. (4.445 mm) O.D. Halar Jacket (E-CTFE) 0.010 in. (0.254 mm) wall 0.144 in. (3.6576 mm) O.D.
DC Resistance	15.2 Ohms/1000 feet (50 Ohms/km) nominal
Capacitance	12.5 pF/ft (41 pF/meter) nominal conductor to conductor
Characteristic Impedance	100 Ohms nominal
Weight	12 lb/1000 feet (17.9 kg/km)
UL Temperature Rating	SmokeGard 167°F (75°C) Halar -40 to 302°F (-40 to 150°C)
Voltage	300 Vac, power limited
Listing	UL: NEC CL2P, or better

LEGEND

- AWG — American Wire Gage
- CL2P — Class 2 Plenum Cable
- DC — Direct Current
- FEP — Fluorinated Ethylene Polymer
- NEC — National Electrical Code
- O.D. — Outside Diameter
- TC — Tinned Copper
- UL — Underwriters Laboratories

Table 36 — Open System Wiring Specifications and Recommended Vendors

WIRING SPECIFICATIONS		RECOMMENDED VENDORS AND PART NUMBERS			
Wire Type	Description	Connect Air International	Belden	RMCORP	Contractors Wire and Cable
MS/TP Network (RS-485)	22 AWG, single twisted shielded pair, low capacitance, CL2P, TC foam FEP, plenum rated. See MS/TP Installation Guide for specifications.	W221P-22227	—	25160PV	CLP0520LC
	24 AWG, single twisted shielded pair, low capacitance, CL2P, TC foam FEP, plenum rated. See MS/TP Installation Guide for specifications.	W241P-2000F	82841	25120-OR	—
Rnet	4 conductor, unshielded, CMP, 18 AWG, plenum rated.	W184C-2099BLB	6302UE	21450	CLP0442

LEGEND

- AWG — American Wire Gage
- CL2P — Class 2 Plenum Cable
- CMP — Communications Plenum Rated
- FEP — Fluorinated Ethylene Polymer
- TC — Tinned Copper

APPENDIX A
Unit Pressure Drop Curves, 30RAP011-060 (English)

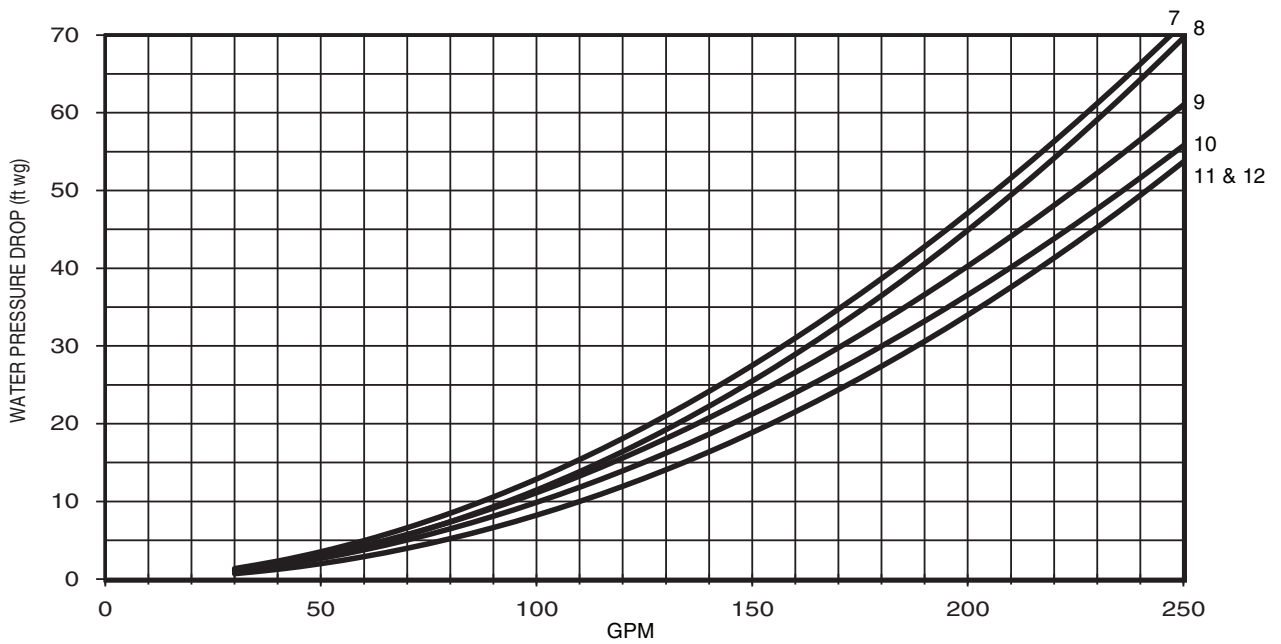
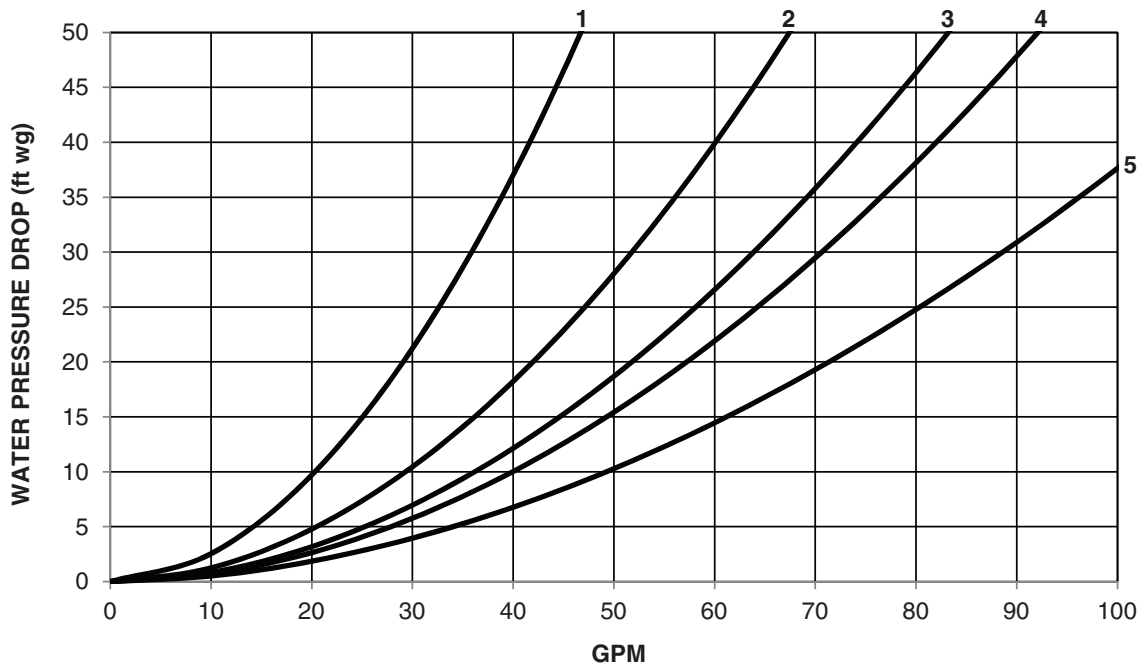

NOTES:

1. Use the following formula to convert feet of water to psig:
 $\text{ft of water} \times .4335 = \text{psig}$
2. Use the following formula to convert psig to feet of water:
 $\text{psig} \times 2.306 = \text{ft of water}$
3. Pressure drop curves are suitable for water only.
4. Includes strainer and unit piping.

LEGEND

1 — 30RAP011	4 — 30RAP025	7 — 30RAP035	10 — 30RAP050
2 — 30RAP016,018	5 — 30RAP030	8 — 30RAP040	11 — 30RAP055
3 — 30RAP020		9 — 30RAP045	12 — 30RAP060

UNITS WITHOUT HYDRONIC PACKAGE

APPENDIX A (cont)
Unit Pressure Drop Curves, 30RAP011-060 (SI)

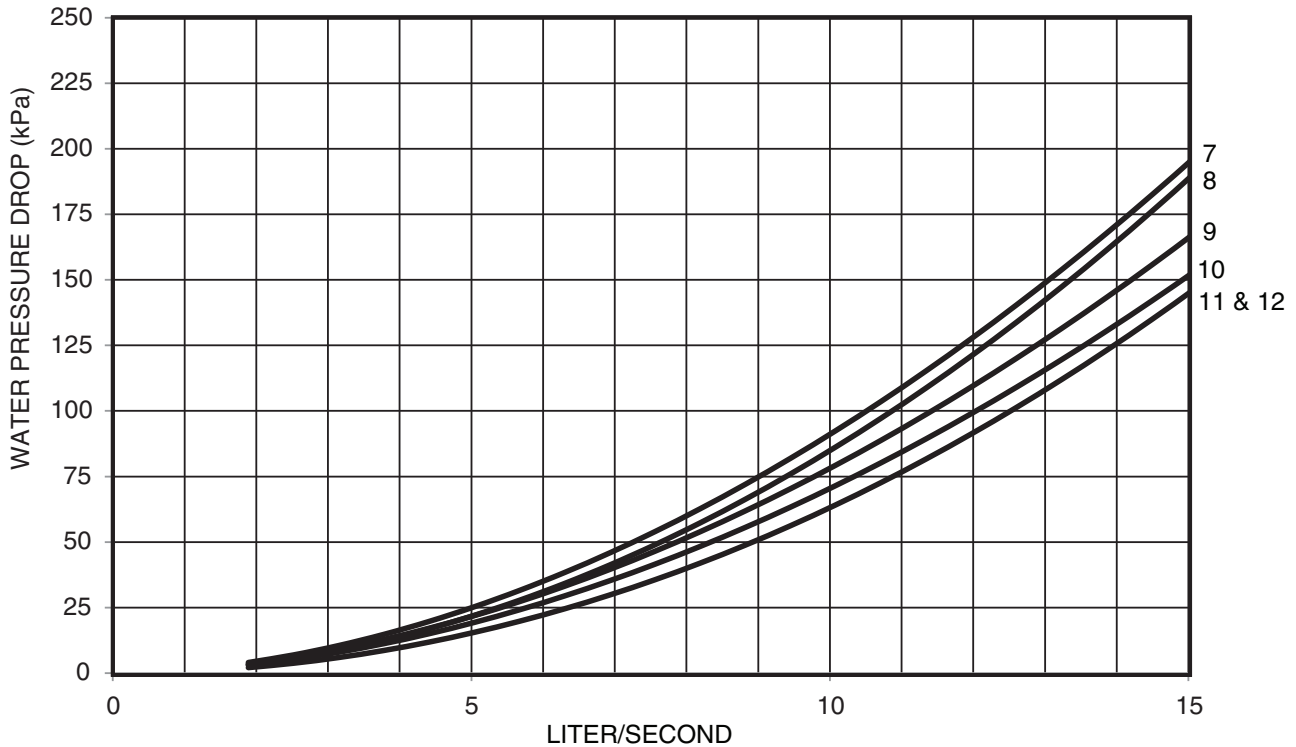
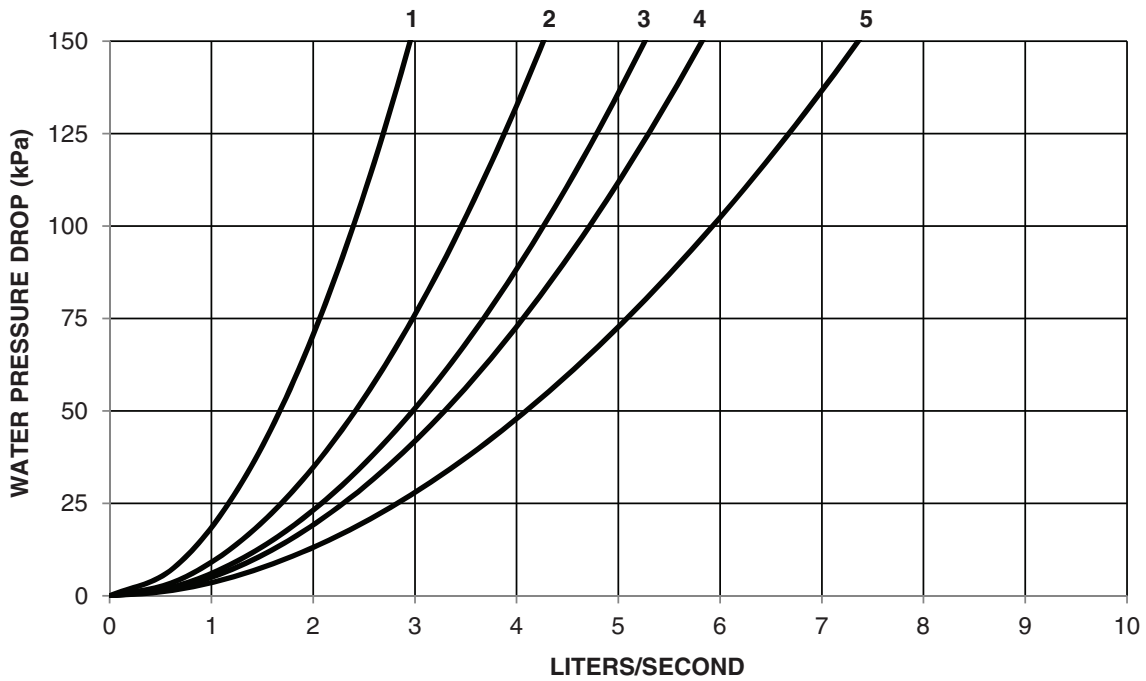

NOTES:
 1. Pressure drop curves are suitable for water only.
 2. Includes strainer and unit piping.

LEGEND			
1 — 30RAP011	4 — 30RAP025	7 — 30RAP035	10 — 30RAP050
2 — 30RAP016,018	5 — 30RAP030	8 — 30RAP040	11 — 30RAP055
3 — 30RAP020		9 — 30RAP045	12 — 30RAP060

UNITS WITHOUT HYDRONIC PACKAGE (cont)

APPENDIX A (cont)

Unit Pressure Drop Curves, 30RAP070-090 (English)

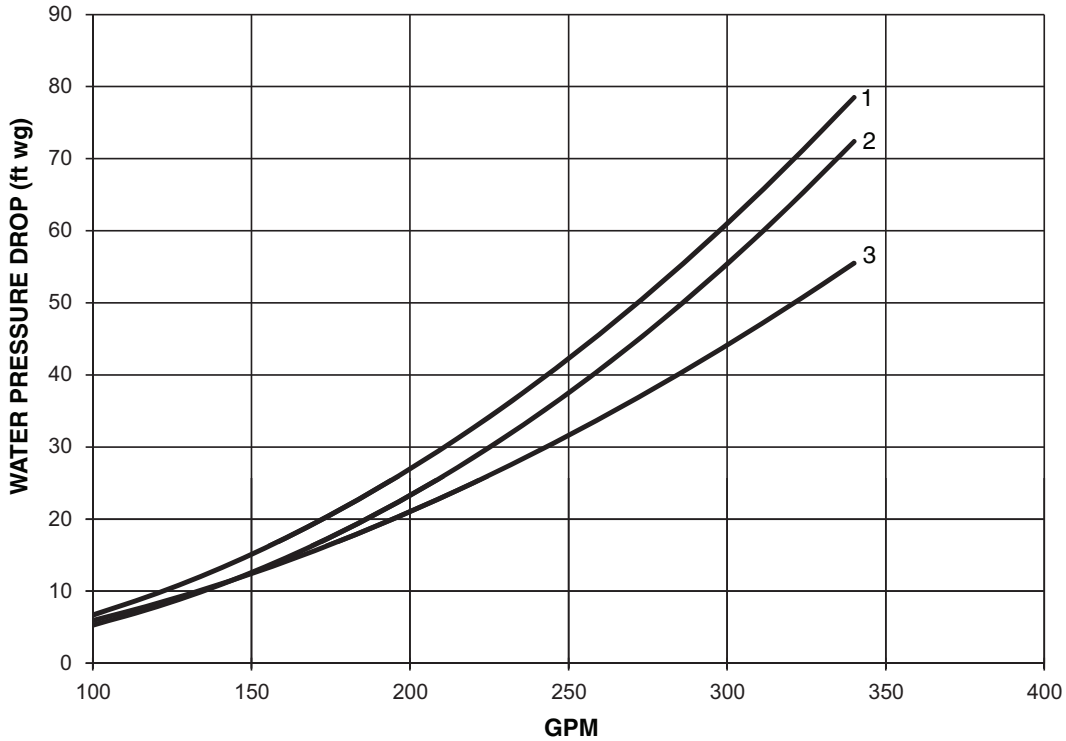

NOTES:

1. Use the following formula to convert feet of water to psig:
ft of water (.4335) = psig
2. Use the following formula to convert psig to feet of water:
psig (2.306) = ft of water
3. Pressure drop curves are suitable for water only.
4. Includes strainer and unit piping.

- LEGEND
- 1 — 30RAP070
 - 2 — 30RAP080
 - 3 — 30RAP090

Unit Pressure Drop Curves, 30RAP070-090 (SI)

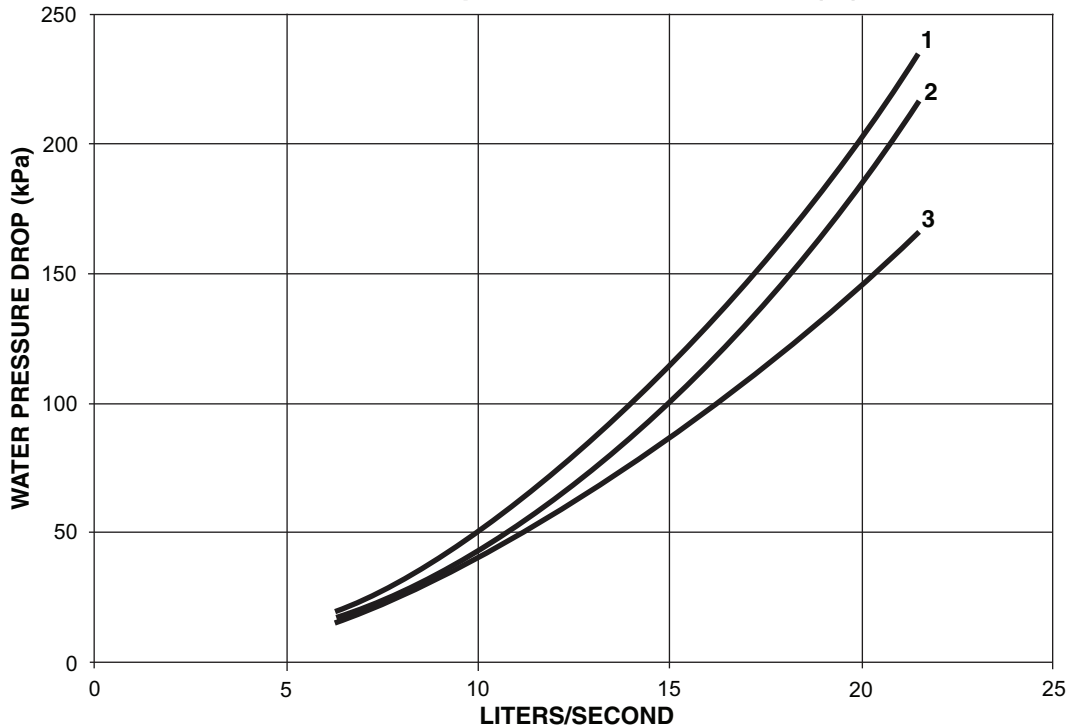

NOTES:

1. Pressure drop curves are suitable for water only.
2. Includes strainer and unit piping.

- LEGEND
- 1 — 30RAP070
 - 2 — 30RAP080
 - 3 — 30RAP090

UNITS WITHOUT HYDRONIC PACKAGE (cont)

APPENDIX A (cont)
Unit Pressure Drop Curves, 30RAP100-150 (English)

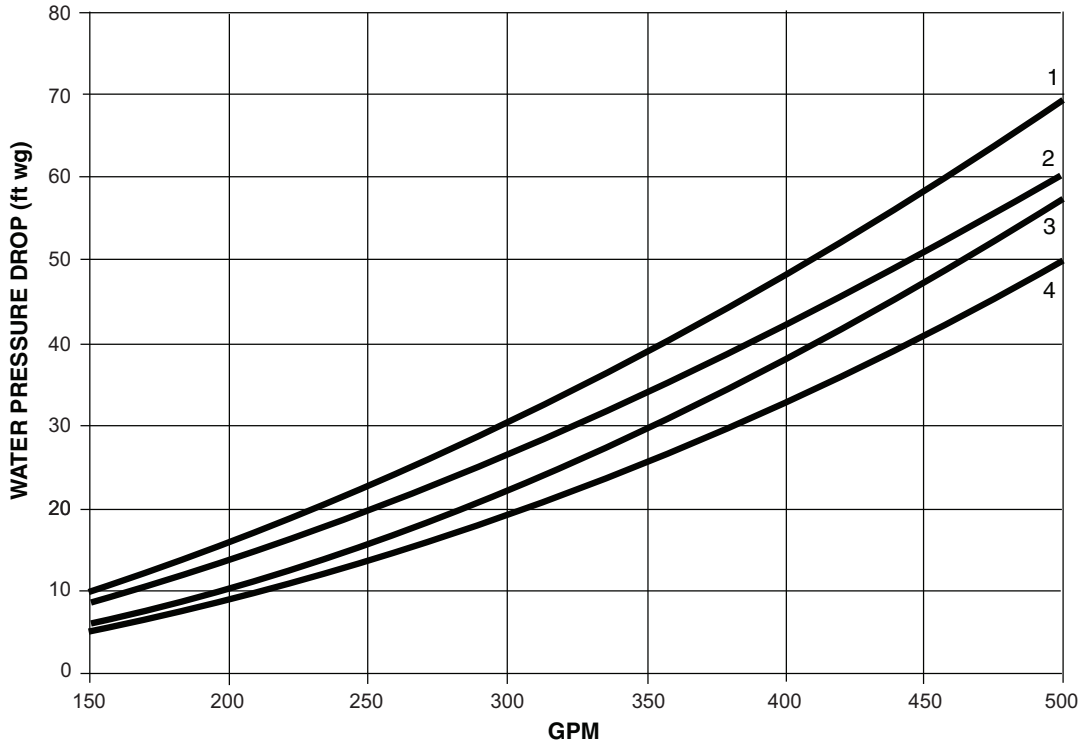

NOTES:

1. Use the following formula to convert feet of water to psig:
 $\text{ft of water} (.4335) = \text{psig}$
2. Use the following formula to convert psig to feet of water:
 $\text{psig} (2.306) = \text{ft of water}$
3. Pressure drop curves are suitable for water only.
4. Includes strainer and unit piping.

LEGEND

- 1 — 30RAP100
- 2 — 30RAP115
- 3 — 30RAP130
- 4 — 30RAP150

Unit Pressure Drop Curves, 30RAP100-150 (SI)

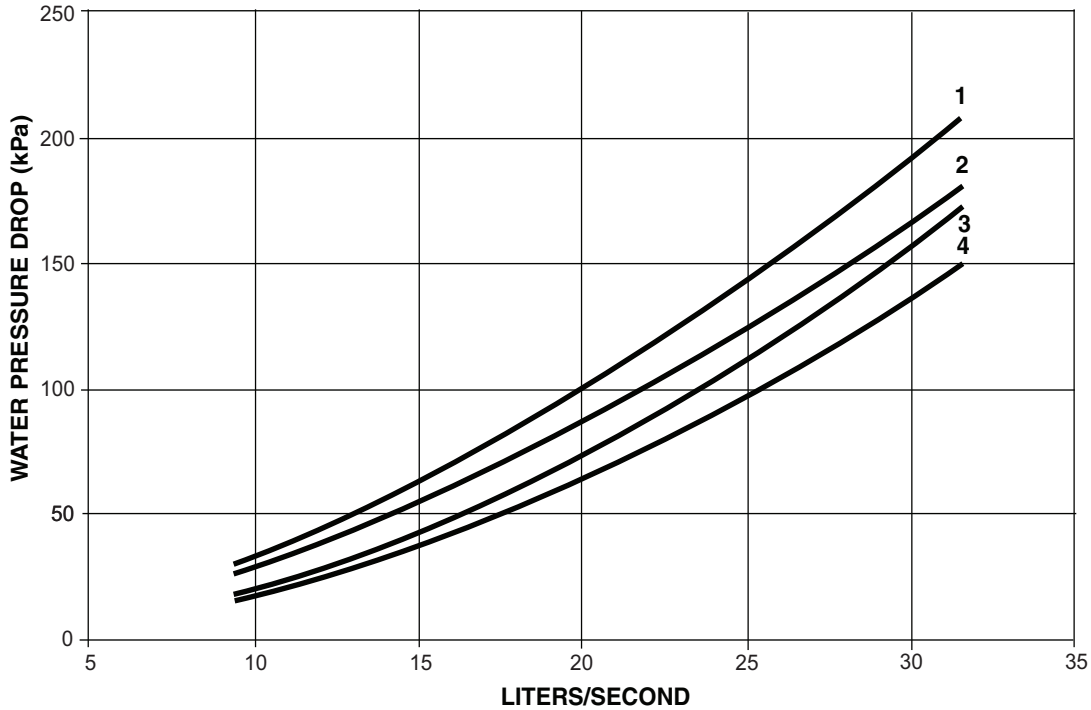

NOTES:

1. Pressure drop curves are suitable for water only.
2. Includes strainer and unit piping.

LEGEND

- 1 — 30RAP100
- 2 — 30RAP115
- 3 — 30RAP130
- 4 — 30RAP150

UNITS WITHOUT HYDRONIC PACKAGE (cont)

APPENDIX A (cont)
Unit Pressure Drop Curves, 30RAP011-060 (English)

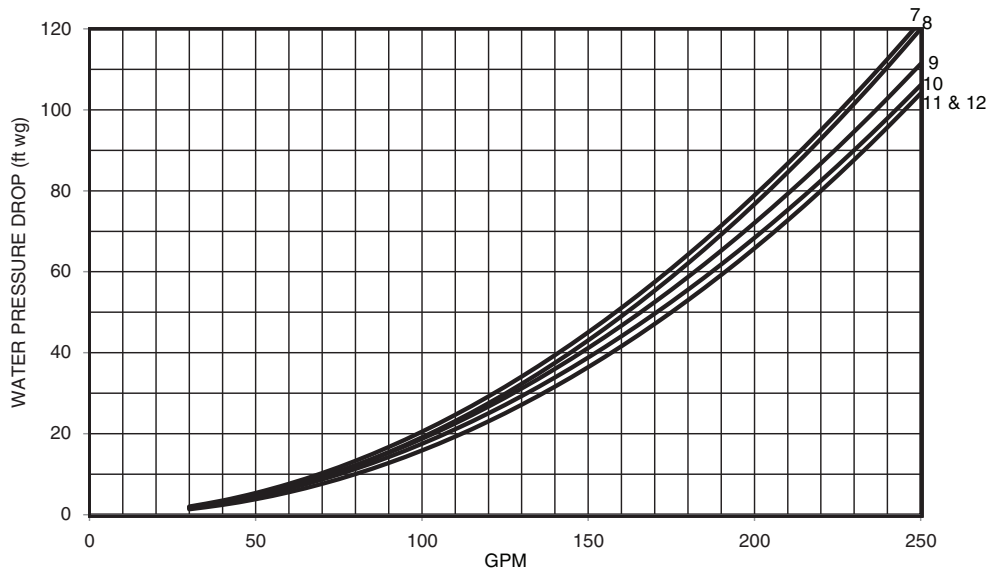
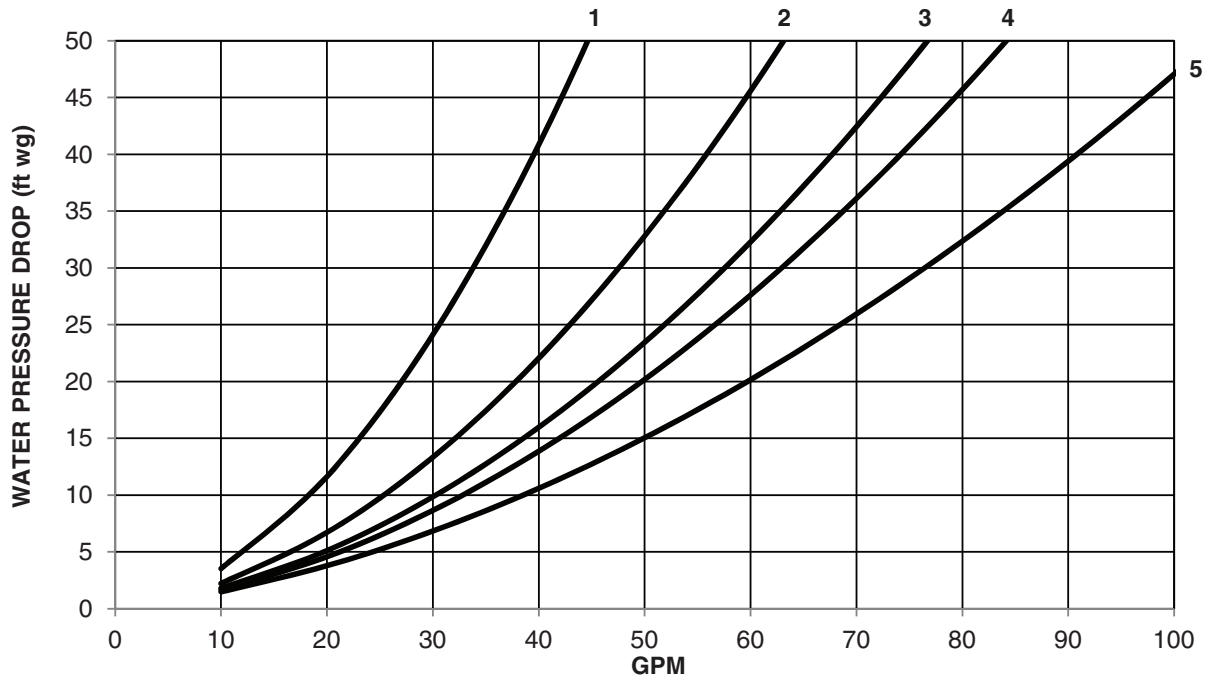

- NOTES:**
- Use the following formula to convert feet of water to psig:
ft of water (.4335) = psig
 - Use the following formula to convert psig to feet of water:
psig (2.306) = ft of water
 - Pressure drop curves are suitable for water only.
 - Includes strainer and unit piping.

LEGEND			
1 — 30RAP011	4 — 30RAP025	7 — 30RAP035	10 — 30RAP050
2 — 30RAP016,018	5 — 30RAP030	8 — 30RAP040	11 — 30RAP055
3 — 30RAP020		9 — 30RAP045	12 — 30RAP060

UNITS WITH SINGLE PUMP HYDRONIC PACKAGE

APPENDIX A (cont)
Unit Pressure Drop Curves, 30RAP011-060 (SI)

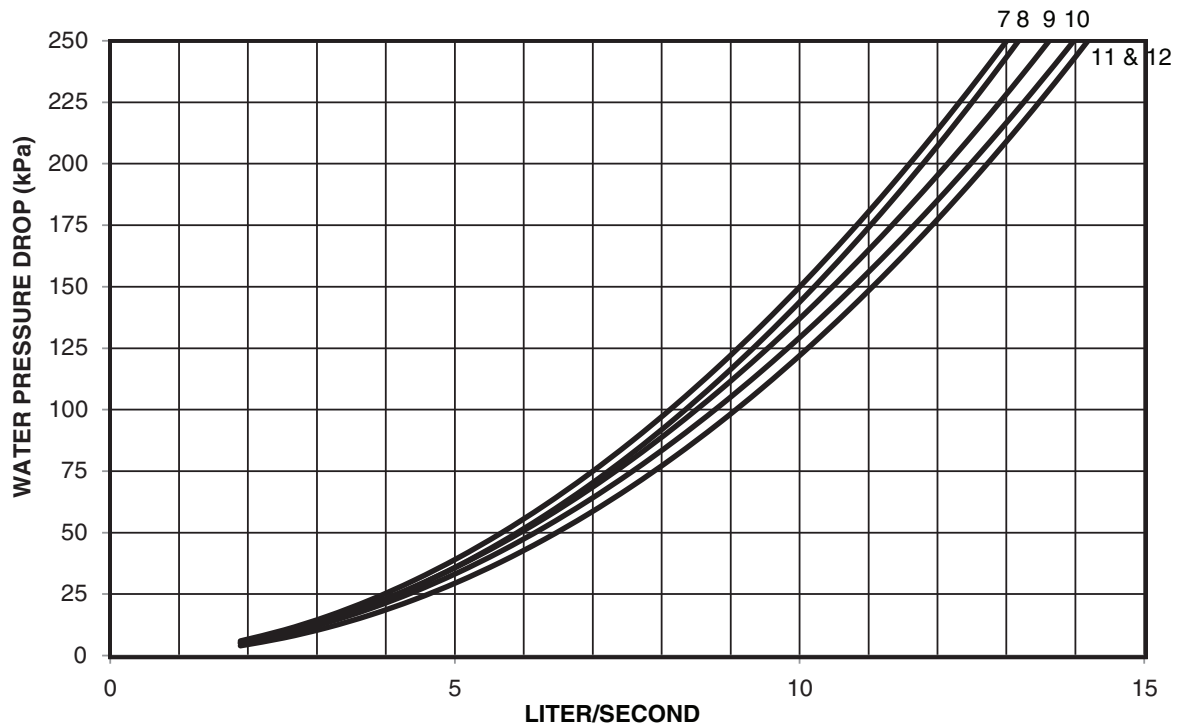
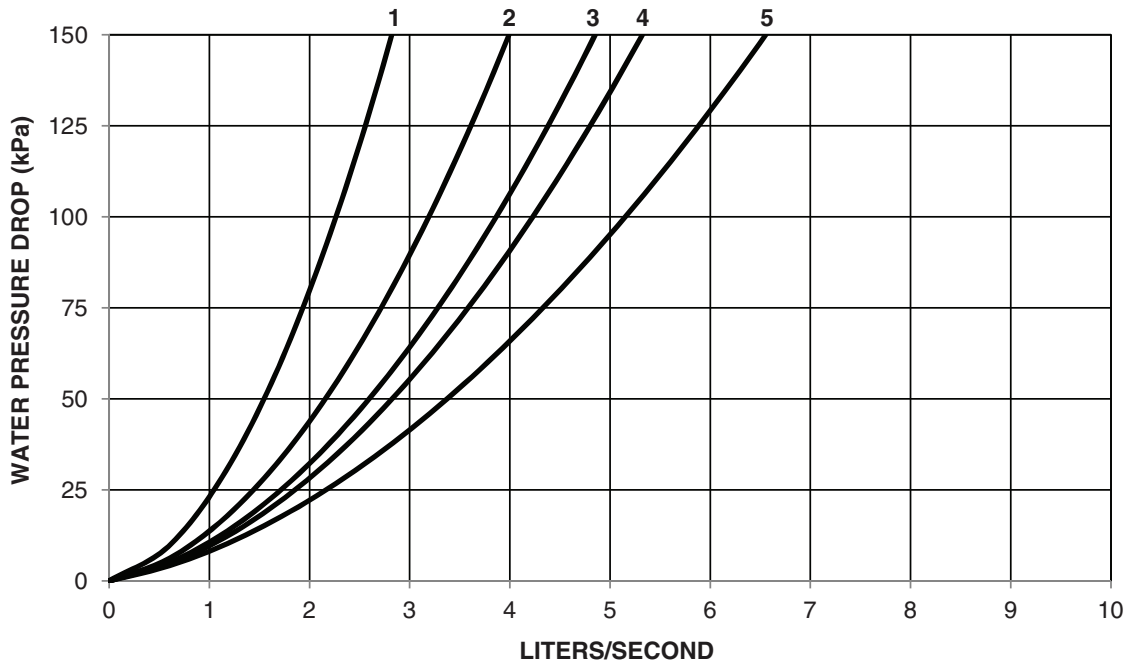

NOTES:
 1. Pressure drop curves are suitable for water only.
 2. Includes strainer and unit piping.

LEGEND			
1 — 30RAP011	4 — 30RAP025	7 — 30RAP035	10 — 30RAP050
2 — 30RAP016,018	5 — 30RAP030	8 — 30RAP040	11 — 30RAP055
3 — 30RAP020		9 — 30RAP045	12 — 30RAP060

UNITS WITH SINGLE PUMP HYDRONIC PACKAGE (cont)

APPENDIX A (cont)
Unit Pressure Drop Curves, 30RAP070-090 (English)

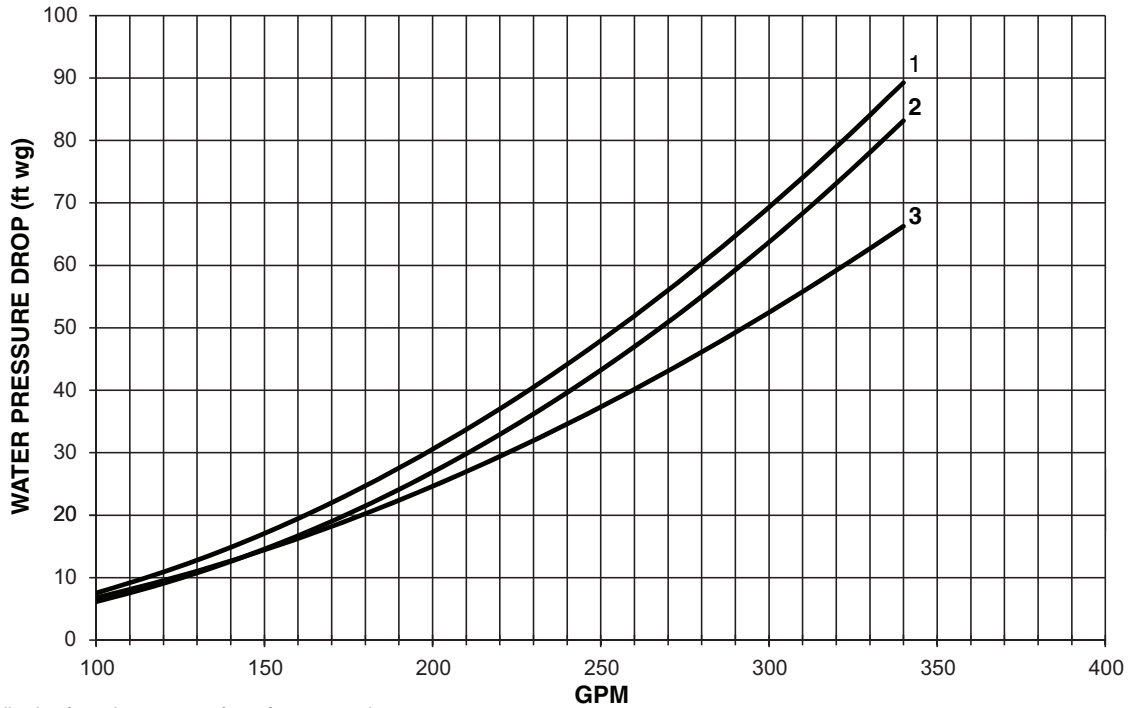

NOTES:

1. Use the following formula to convert feet of water to psig:
ft of water (.4335) = psig
2. Use the following formula to convert psig to feet of water:
psig (2.306) = ft of water
3. Pressure drop curves are suitable for water only.
4. Includes strainer and unit piping.

LEGEND
1 — 30RAP070
2 — 30RAP080
3 — 30RAP090

Unit Pressure Drop Curves, 30RAP070-090 (SI)

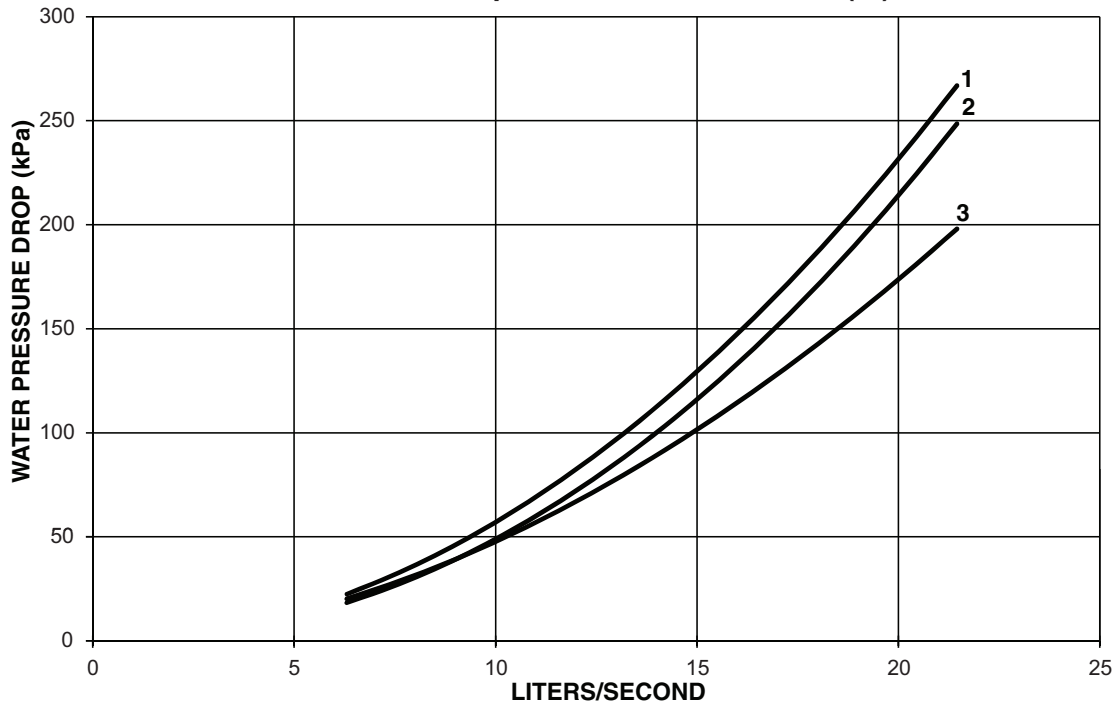

NOTES:

1. Pressure drop curves are suitable for water only.
2. Includes strainer and unit piping.

LEGEND
1 — 30RAP070
2 — 30RAP080
3 — 30RAP090

UNITS WITH SINGLE PUMP HYDRONIC PACKAGE (cont)

APPENDIX A (cont)
Unit Pressure Drop Curves, 30RAP100-150 (English)

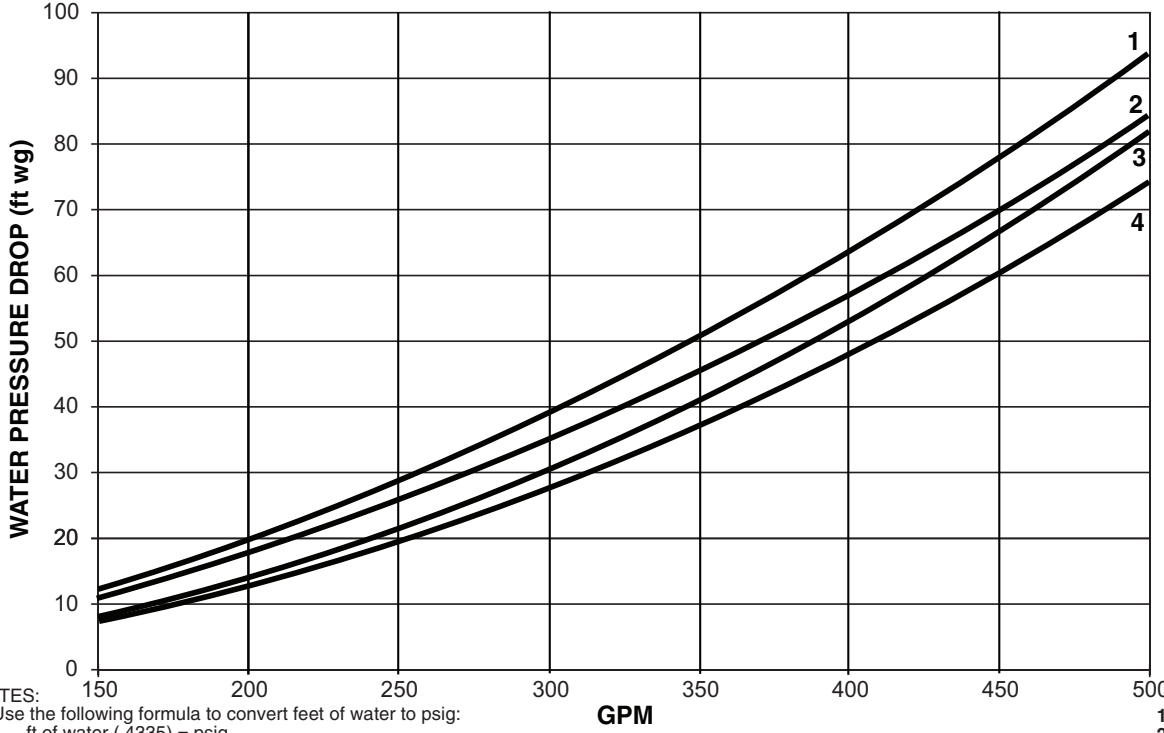

NOTES:

1. Use the following formula to convert feet of water to psig:
ft of water (.4335) = psig
2. Use the following formula to convert psig to feet of water:
psig (2.306) = ft of water
3. Pressure drop curves are suitable for water only.
4. Includes strainer and unit piping.

LEGEND

- 1 — 30RAP100
- 2 — 30RAP115
- 3 — 30RAP130
- 4 — 30RAP150

Unit Pressure Drop Curves, 30RAP100-150 (SI)

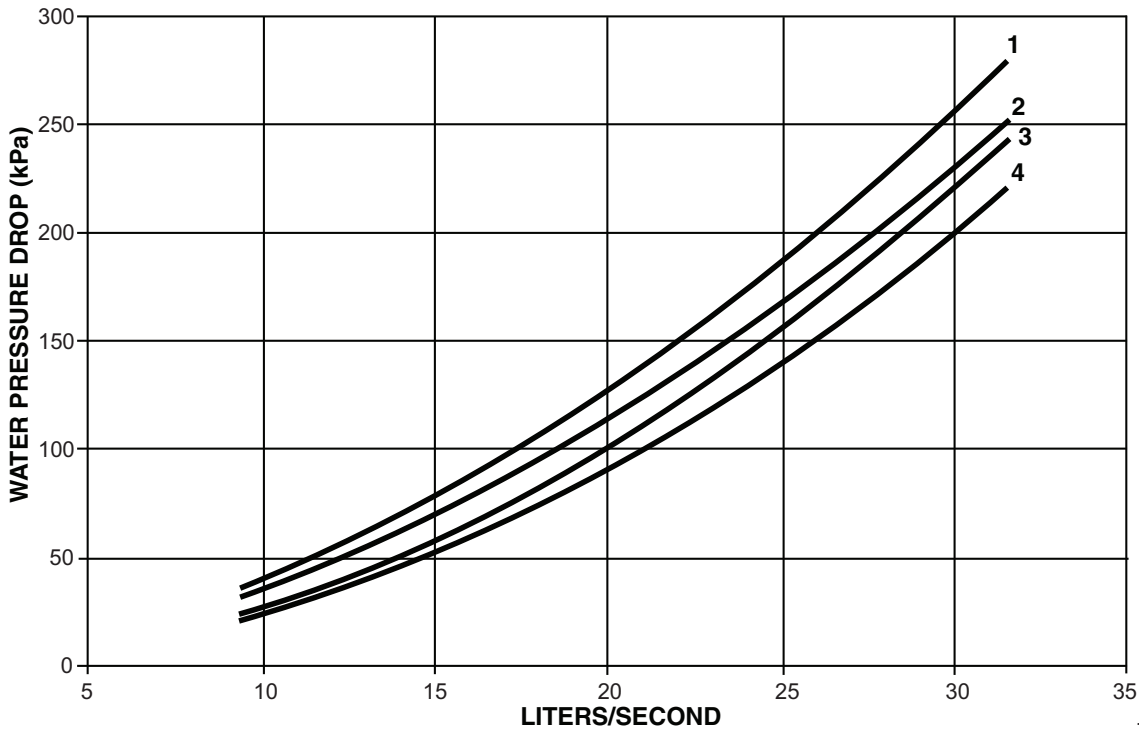

NOTES:

1. Pressure drop curves are suitable for water only.
2. Includes strainer and unit piping.

LEGEND

- 1 — 30RAP100
- 2 — 30RAP115
- 3 — 30RAP130
- 4 — 30RAP150

UNITS WITH SINGLE PUMP HYDRONIC PACKAGE (cont)

APPENDIX A (cont)
Unit Pressure Drop Curves, 30RAP011-060 (English)

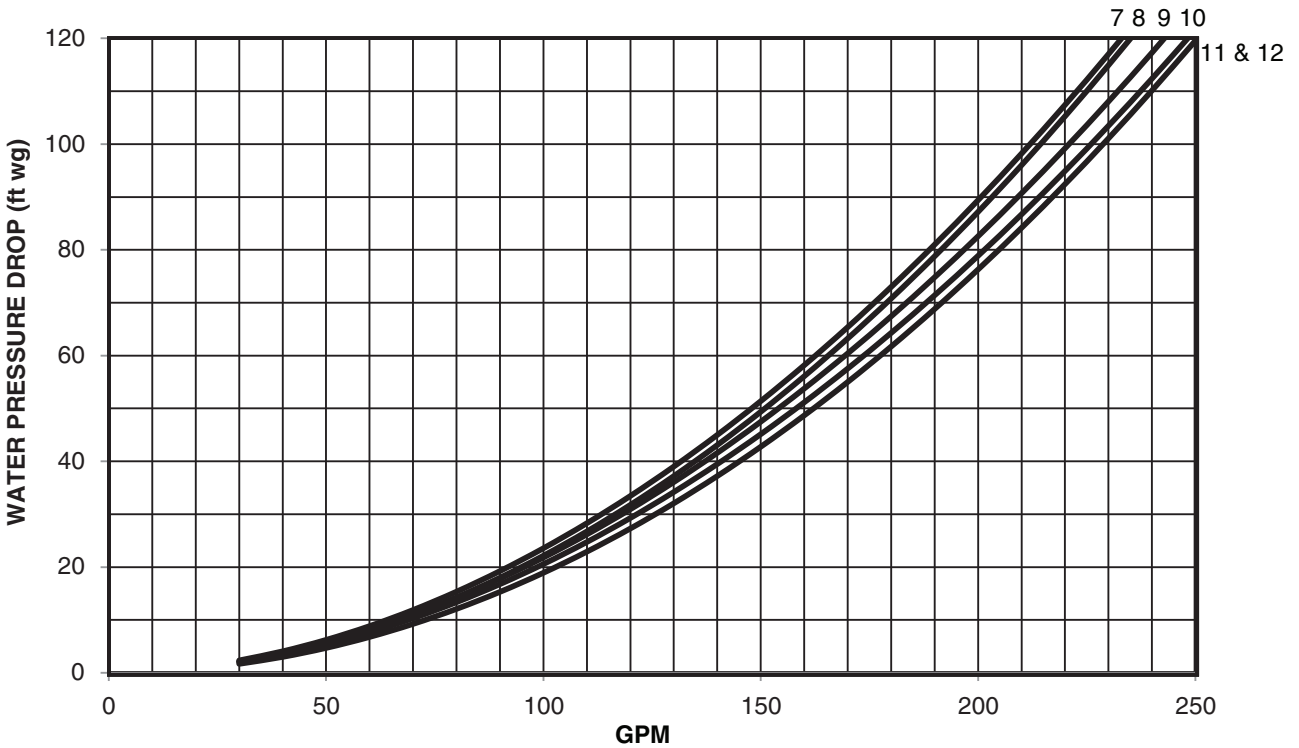
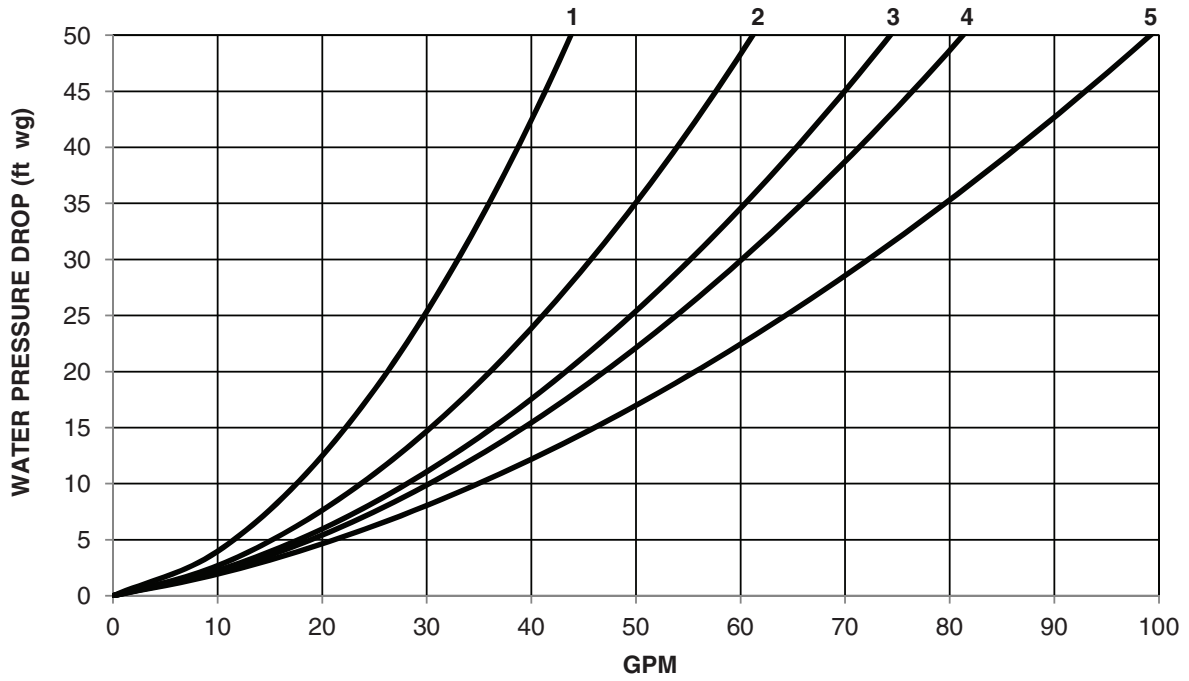

NOTES:

1. Use the following formula to convert feet of water to psig:
ft of water (.4335) = psig
2. Use the following formula to convert psig to feet of water:
psig (2.306) = ft of water
3. Pressure drop curves are suitable for water only.
4. Includes strainer and unit piping.

LEGEND

- | | | | |
|------------------|--------------|--------------|---------------|
| 1 — 30RAP011 | 4 — 30RAP025 | 7 — 30RAP035 | 10 — 30RAP050 |
| 2 — 30RAP016,018 | 5 — 30RAP030 | 8 — 30RAP040 | 11 — 30RAP055 |
| 3 — 30RAP020 | | 9 — 30RAP045 | 12 — 30RAP060 |

UNITS WITH DUAL PUMP HYDRONIC PACKAGE

APPENDIX A (cont)
Unit Pressure Drop Curves, 30RAP011-060 (SI)

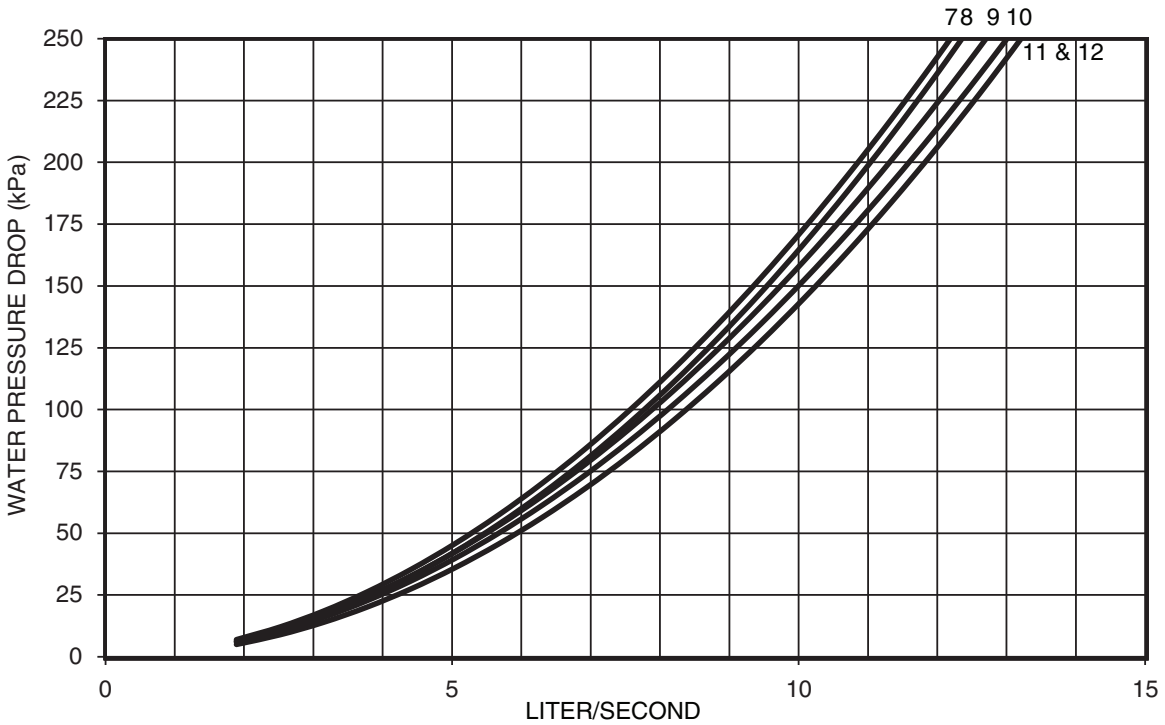
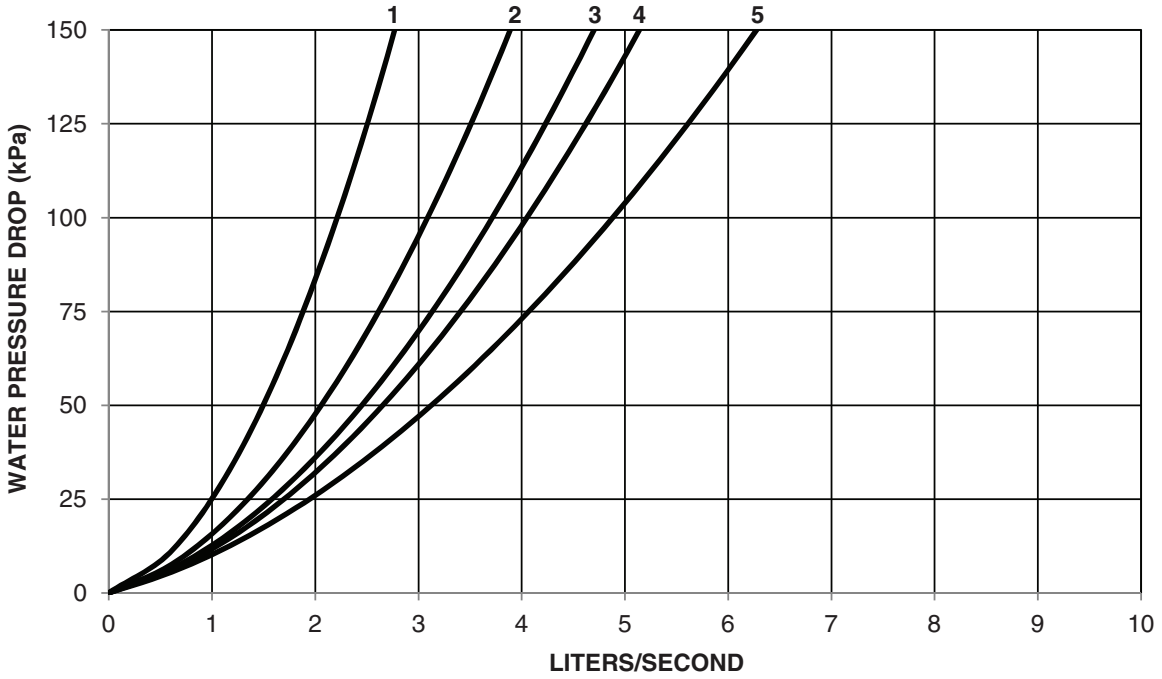

NOTES:

1. Pressure drop curves are suitable for water only.
2. Includes strainer and unit piping.

LEGEND

- | | | | |
|------------------|--------------|--------------|---------------|
| 1 — 30RAP011 | 4 — 30RAP025 | 7 — 30RAP035 | 10 — 30RAP050 |
| 2 — 30RAP016,018 | 5 — 30RAP030 | 8 — 30RAP040 | 11 — 30RAP055 |
| 3 — 30RAP020 | | 9 — 30RAP045 | 12 — 30RAP060 |

UNITS WITH DUAL PUMP HYDRONIC PACKAGE (cont)

APPENDIX A (cont)

Unit Pressure Drop Curves, 30RAP070-090 (English)

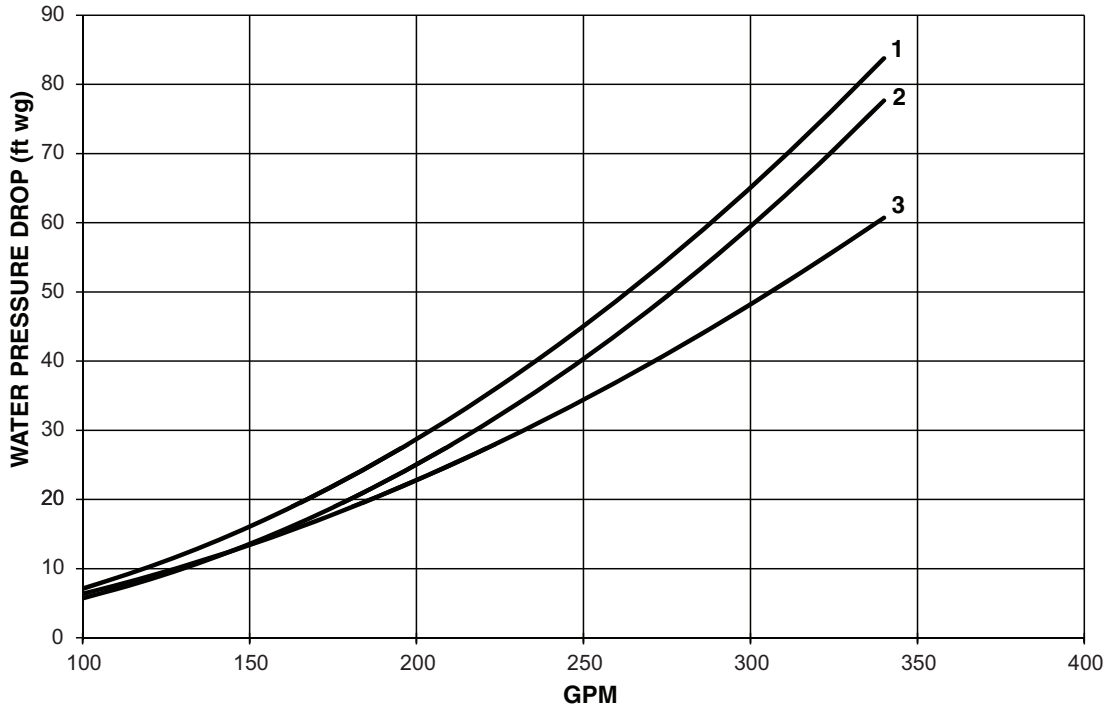

NOTES:

1. Use the following formula to convert feet of water to psig:
ft of water (.4335) = psig
2. Use the following formula to convert psig to feet of water:
psig (2.306) = ft of water
3. Pressure drop curves are suitable for water only.
4. Includes strainer and unit piping.

LEGEND

- 1 — 30RAP070
- 2 — 30RAP080
- 3 — 30RAP090

Unit Pressure Drop Curves, 30RAP070-090 (SI)

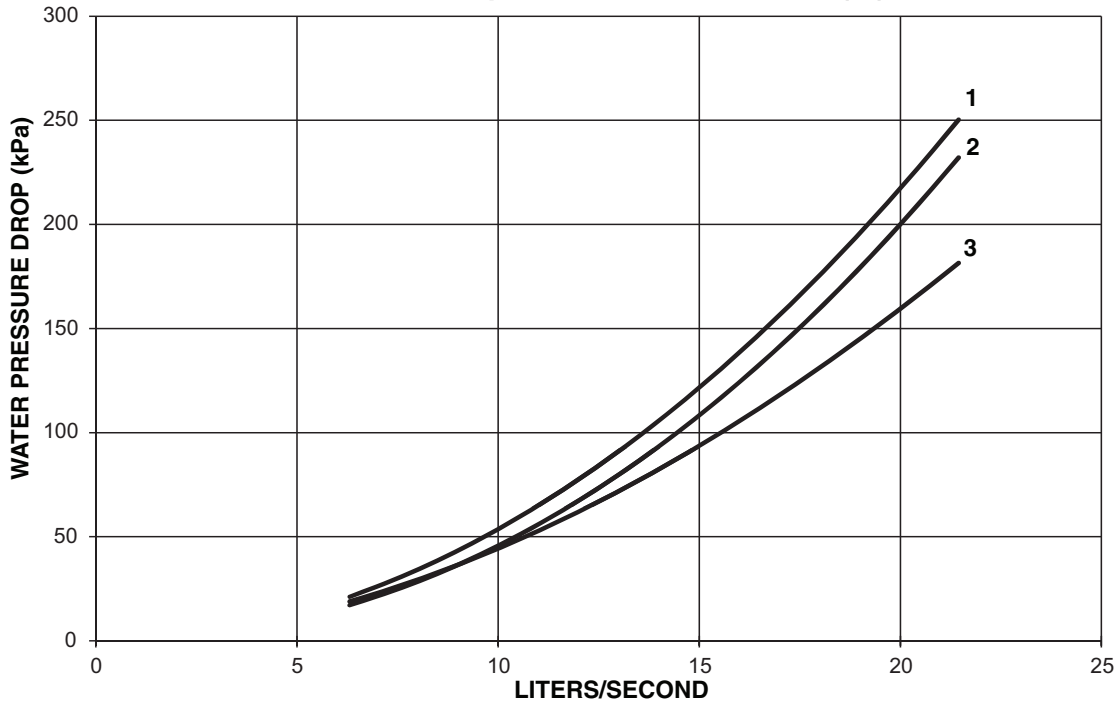

NOTES:

1. Pressure drop curves are suitable for water only.
2. Includes strainer and unit piping.

LEGEND

- 1 — 30RAP070
- 2 — 30RAP080
- 3 — 30RAP090

UNITS WITH DUAL PUMP HYDRONIC PACKAGE (cont)

APPENDIX A (cont)
Unit Pressure Drop Curves, 30RAP100-150 (English)

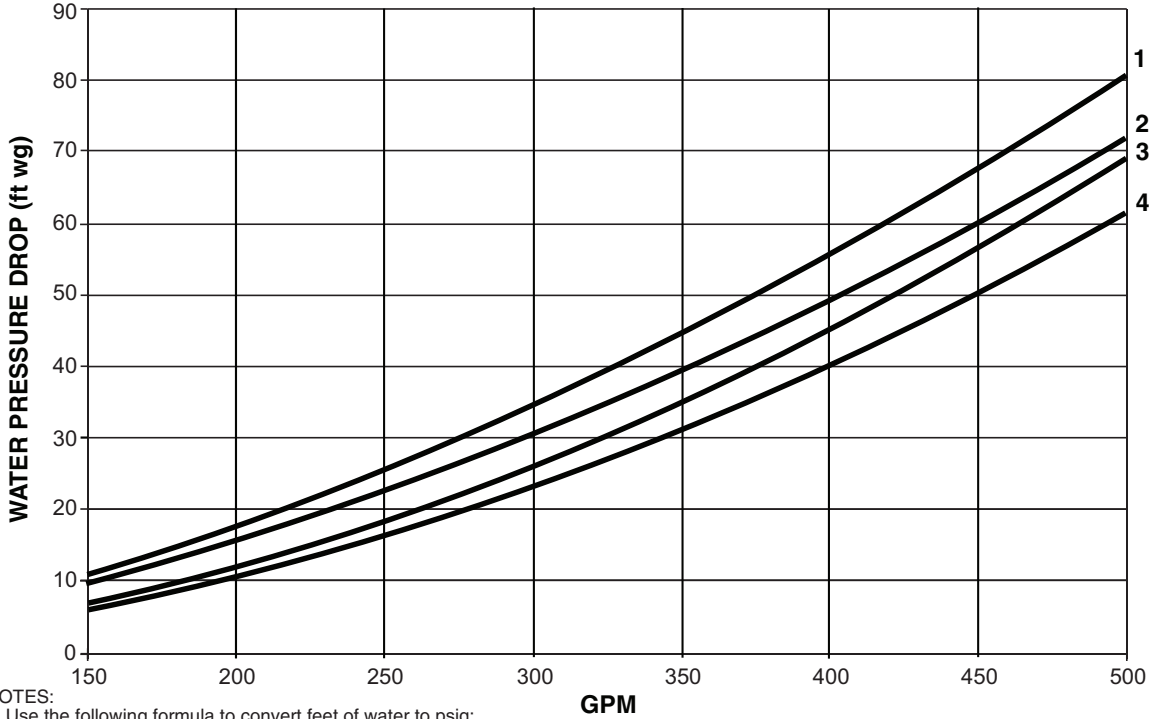

NOTES:

1. Use the following formula to convert feet of water to psig:
ft of water (.4335) = psig
2. Use the following formula to convert psig to feet of water:
psig (2.306) = ft of water
3. Pressure drop curves are suitable for water only.
4. Includes strainer and unit piping.

LEGEND

- 1 — 30RAP100
- 2 — 30RAP115
- 3 — 30RAP130
- 4 — 30RAP150

Unit Pressure Drop Curves, 30RAP100-150 (SI)

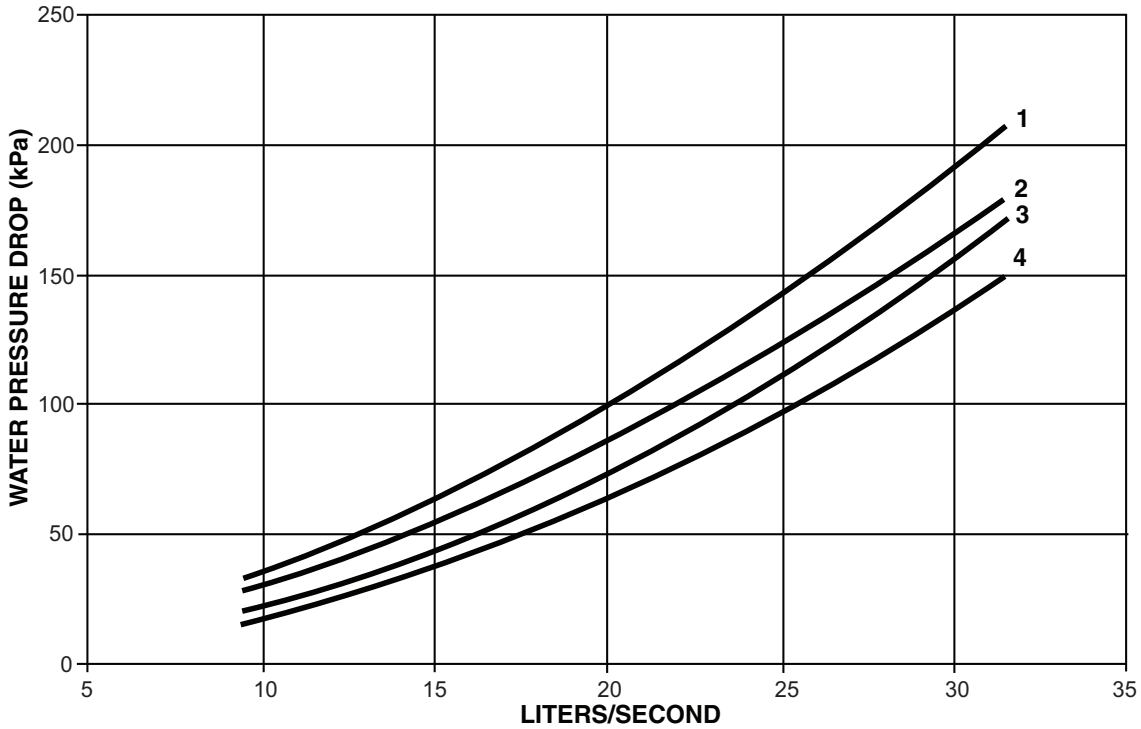

NOTES:

1. Pressure drop curves are suitable for water only.
2. Includes strainer and unit piping.

LEGEND

- 1 — 30RAP100
- 2 — 30RAP115
- 3 — 30RAP130
- 4 — 30RAP150

UNITS WITH DUAL PUMP HYDRONIC PACKAGE (cont)

APPENDIX A (cont)

Pressure Drop Curves, Accessory Storage Tanks

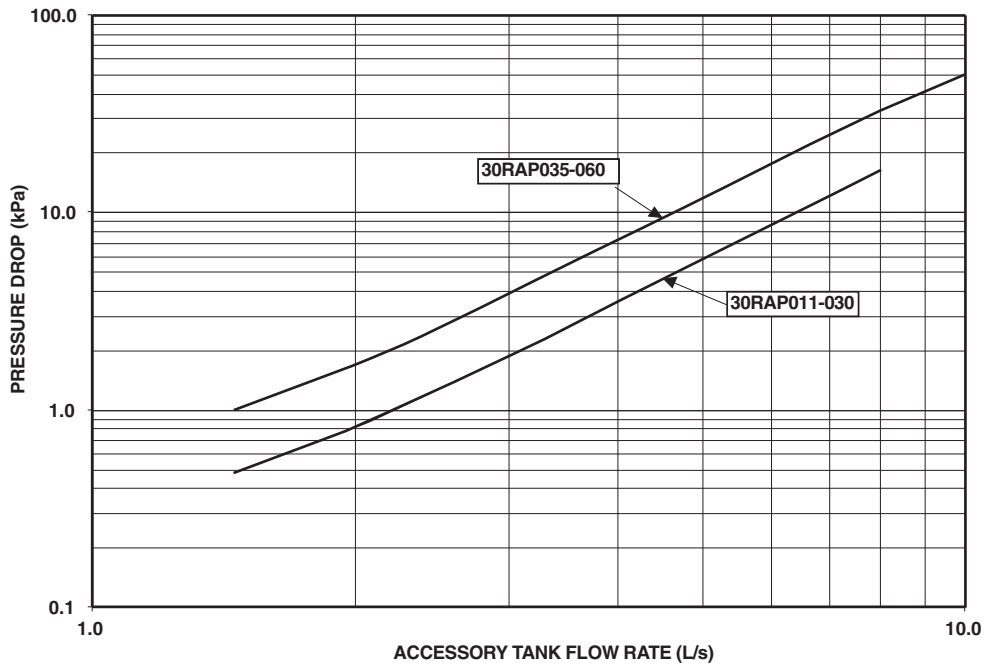
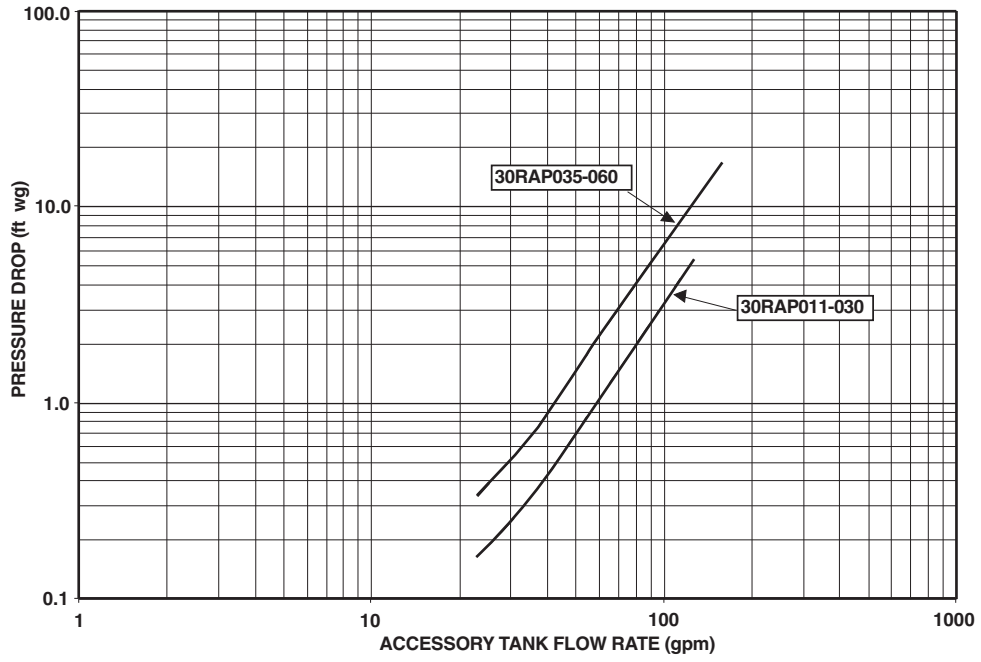

START-UP CHECKLIST FOR 30RAP LIQUID CHILLER
(Remove and use for Job File)

I. Project Information

JOB NAME _____

ADDRESS _____

CITY _____ STATE _____ ZIP _____

INSTALLING CONTRACTOR _____

SALES OFFICE _____

START-UP PERFORMED BY _____

UNIT MODEL _____ SERIAL _____

II. Preliminary Equipment Check (to be performed by installing contractor)

IS THERE ANY PHYSICAL DAMAGE? YES NO

IF YES, WAS IT NOTED ON THE FREIGHT BILL, AND HAS A CLAIM BEEN FILED WITH THE SUPPLIER? YES NO

DESCRIPTION _____

1. UNIT IS INSTALLED LEVEL AS PER THE INSTALLATION INSTRUCTIONS. YES NO

2. POWER SUPPLY AGREES WITH THE UNIT NAMEPLATE. YES NO

3. ELECTRICAL POWER WIRING IS INSTALLED PROPERLY. YES NO

4. UNIT IS PROPERLY GROUNDED. YES NO

5. ELECTRICAL CIRCUIT PROTECTION HAS BEEN SIZED AND INSTALLED PROPERLY. YES NO

6. ALL TERMINALS ARE TIGHT. YES NO

7. ALL PLUG ASSEMBLIES ARE TIGHT. YES NO

8. REMOVE SHIPPING BRACKETS FROM COMPRESSORS. YES NO

Chilled Water System Check (to be performed by installing contractor)

1. SYSTEM HAS BEEN PROPERLY CLEANED AND FILLED. YES NO

2. ALL CHILLED WATER VALVES ARE OPEN. YES NO

3. ALL PIPING IS CONNECTED PROPERLY. YES NO

4. ALL AIR HAS BEEN PURGED FROM THE SYSTEM. YES NO

5. CHILLED WATER PUMP IS OPERATING WITH THE CORRECT ROTATION. YES NO

- 6. CHILLED WATER PUMP STARTER INTERLOCKED WITH CHILLER. YES NO
- 7. INTEGRATED 40 MESH Y STRAINER CLEAN. YES NO
- 8. WATER LOOP VOLUME GREATER THAN MINIMUM REQUIREMENTS. (See Table 20). YES NO
- 9. PROPER LOOP FREEZE PROTECTION PROVIDED TO _____ °F (°C). YES NO
 ANTIFREEZE TYPE _____ CONCENTRATION _____ %.
 IF OUTDOOR AMBIENT IS BELOW 32 F (0° C) THEN ITEMS 9-11 HAVE TO BE
 COMPLETED TO PROVIDE COOLER FREEZE PROTECTION TO -20 F (-29 C). (REFER
 TO WINTER SHUTDOWN FOR PROPER COOLER WINTERIZATION PROCEDURE.)

NOTE: GLYCOL CONCENTRATIONS ABOVE 30% MAY REQUIRE A FLOW SWITCH RE-CALIBRATION.

- 10. OUTDOOR PIPING WRAPPED WITH ELECTRIC HEATER TAPE,
INSULATED AND OPERATIONAL. YES NO
- 11. COOLER HEATERS INSTALLED AND OPERATIONAL. YES NO
- 12. CHILLED WATER PUMP CONTROLLED BY CHILLER. YES NO
- 13. CRANKCASE HEATERS (IF EQUIPPED) ARE SECURELY ATTACHED, OPERATIONAL,
AND ENERGIZED TO REMOVE ANY LIQUID FROM THE COMPRESSOR. YES NO

SIGNATURE REQUIRED

PRELIMINARY START-UP COMPLETE.

INSTALLING/MECHANICAL CONTRACTOR _____ DATE _____

III. Unit Start-Up (Qualified individuals only. Factory start-up recommended.)

Design Information

CAPACITY	CEAT	EWT	LWT	FLUID TYPE	FLOW RATE	P.D.

- 1. ALL CABLES AND THERMISTORS HAVE BEEN INSPECTED FOR CROSSED WIRES. YES NO
- 2. ALL THERMISTORS ARE FULLY INSERTED INTO WELLS. YES NO
- 3. COMPRESSOR OIL LEVEL IS CORRECT. YES NO
- 4. VERIFY CRANKCASE HEATERS (IF EQUIPPED) HAVE BEEN ENERGIZED
FOR 24 HOURS. YES NO
- 5. VERIFY COMPRESSOR MOUNTING BOLT TORQUE IS 7-10 FT-LB. (9.5-13.5 N-M). YES NO
- 6. LEAK CHECK UNIT. LOCATE, REPAIR AND REPORT ANY REFRIGERANT LEAKS. YES NO
- 7. VOLTAGE IS WITHIN UNIT NAMEPLATE RANGE. YES NO
- 8. CONTROL TRANSFORMER PRIMARY CONNECTION SET FOR PROPER VOLTAGE. YES NO
- 9. CONTROL TRANSFORMER SECONDARY VOLTAGE = _____

CUT ALONG DOTTED LINE

CUT ALONG DOTTED LINE

10. CHECK VOLTAGE IMBALANCE: A-B _____ A-C _____ B-C _____
 AVERAGE VOLTAGE = _____ (A-B + A-C + B-C)/3
 MAXIMUM DEVIATION FROM AVERAGE VOLTAGE = _____
 VOLTAGE IMBALANCE = _____% (MAX. DEVIATION/AVERAGE VOLTAGE) X 100
 VOLTAGE IMBALANCE LESS THAN 2%. YES NO
 (DO NOT START CHILLER IF VOLTAGE IMBALANCE IS GREATER THAN 2%.
 CONTACT LOCAL UTILITY FOR ASSISTANCE.)
11. VERIFY COOLER FLOW RATE. YES NO
 PRESSURE ENTERING COOLER _____ psig (kPa)
 PRESSURE LEAVING COOLER _____ psig (kPa)
 COOLER PRESSURE DROP _____ psig (kPa)
 Psig X 2.31 ft./psi = _____ ft of water
 kPa X 0.334 m/psi _____ m of water
 COOLER FLOW RATE _____ gpm (l/s) (See Cooler Pressure
 Drop Curves from
 Installation Instructions)
12. FLOW SWITCH OPERATION CHECKED. YES NO

Start and Operate Machine. Complete the Following:

1. COMPLETE COMPONENT TEST. YES NO
2. CHECK REFRIGERANT AND OIL CHARGE. YES NO
3. RECORD COMPRESSOR MOTOR CURRENT. YES NO
4. RECORD CONFIGURATION SETTINGS. YES NO
5. RECORD OPERATING TEMPERATURES AND PRESSURES. YES NO
6. PROVIDE OPERATING INSTRUCTIONS TO OWNER'S PERSONNEL. Instruction Time _____ hours.

OPERATING DATA:

RECORD THE FOLLOWING INFORMATION FROM THE PRESSURES AND TEMPERATURES MODES WHEN MACHINE IS IN A STABLE OPERATING CONDITION:

PRESSURE/TEMPERATURE

	CIRCUIT A	CIRCUIT B
DISCHARGE PRESSURE	DP.A _____	DP.B _____
SUCTION PRESSURE	SP.A _____	SP.B _____
SATURATED CONDENSING TEMP	SCT.A _____	SCT.B _____
SATURATED SUCTION TEMP	SST.A _____	SST.B _____
RETURN GAS TEMPERATURE	RGT.A _____	RGT.B _____
LIQUID LINE TEMPERATURE*	_____	_____
DISCHARGE LINE TEMPERATURE*	_____	_____

*Readings taken with a digital thermometer.

COOLER EWT	EWT _____	
COOLER LWT	LWT _____	
OUTDOOR-AIR TEMPERATURE	OAT _____	
CONTROL POINT	CTPT _____	
PERCENT TOTAL CAPACITY	CAP _____	
LEAD/LAG LEAVING FLUID	DLWT _____	(Dual Chiller Control Only)

Compressor Running Current — All readings taken at full load.

COMPRESSOR MOTOR CURRENT	L1	L2	L3
COMPRESSOR A1			
COMPRESSOR A2			
COMPRESSOR A3			
COMPRESSOR B1			
COMPRESSOR B2			
COMPRESSOR B3			

CONDENSER FAN MOTOR CURRENT	L1	L2	L3
FAN MOTOR 1			
FAN MOTOR 2			
FAN MOTOR 3			
FAN MOTOR 4			
FAN MOTOR 5			
FAN MOTOR 6			
FAN MOTOR 7			
FAN MOTOR 8			
FAN MOTOR 9			
FAN MOTOR 10			

COOLER PUMP MOTOR CURRENT	L1	L2	L3
COOLER PUMP 1			
COOLER PUMP 2			

**Record Software Versions
MODE — RUN STATUS**

SUB-MODE	ITEM	DISPLAY	ITEM EXPANSION
VERS	MBB		CESR-131460- _ _ _ _
	EXV		CESR-131172- _ _ _ _
	AUX1		CESR-131333- _ _ - _
	EMM		CESR-131174- _ _ - _
	MARQ		CESR-131171- _ _ - _
	NAVI		CESR-131227- _ _ - _
	CXB		CESR-131173- _ _ - _

(PRESS ENTER AND ESCAPE SIMULTANEOUSLY TO OBTAIN SOFTWARE VERSIONS)

CUT ALONG DOTTED LINE

CUT ALONG DOTTED LINE

III. Unit Start-Up (cont)

RECORD CONFIGURATION SETTINGS

UNIT (Configuration Settings)

SUBMODE	ITEM	ITEM EXPANSION	DISPLAY	ENTRY
UNIT		UNIT CONFIGURATION		
	SIZE	UNIT SIZE	XXX	
	SZA.1	COMPRESSOR A1 SIZE	XX	
	SZA.2	COMPRESSOR A2 SIZE	XX	
	SZA.3	COMPRESSOR A3 SIZE	XX	
	SZB.1	COMPRESSOR B1 SIZE	XX	
	SZB.2	COMPRESSOR B2 SIZE	XX	
	SZB.3	COMPRESSOR B3 SIZE	XX	
	SH.SP	SUPERHEAT SETPOINT	XX.X ΔF	
	FAN.S	FAN STAGING SELECT	X	
	EXV	EXV MODULE INSTALLED	YES/NO	
	A1.TY	COMPRESSOR A1 DIGITAL?	YES/NO	
	MAX.T	MAXIMUM A1 UNLOAD TIME	XX	
	FN.SQ	YES, IF UNIT PRODUCED ON OR AFTER 2214 (WWYY) NO, IF UNIT PRODUCED BEFORE 2214 (WWYY)	YES/NO	

PRESS ESCAPE KEY TO DISPLAY 'UNIT'. PRESS DOWN ARROW KEY TO DISPLAY 'OPT1'.
PRESS ENTER KEY. RECORD CONFIGURATION INFORMATION BELOW:

OPTIONS1 (Options Configuration)

SUBMODE	ITEM	ITEM EXPANSION	DISPLAY	ENTRY
OPT1		UNIT OPTIONS 1 HARDWARE		
	FLUD	COOLER FLUID	X	
	MLV.S	MINIMUM LOAD VALVE SELECT	YES/NO	
	CSB.E	CSB BOARDS ENABLE	ENBL/DSBL	
	CPC	COOLER PUMP CONTROL	ON/OFF	
	PM1E	COOLER PUMP 1 ENABLE	YES/NO	
	PM2E	COOLER PUMP 2 ENABLE	YES/NO	
	PM.P.S	COOLER PMP PERIODIC STRT	YES/NO	
	PM.SL	COOLER PUMP SELECT	X	
	PM.DY	COOLER PUMP SHUTDOWN DLY	XX MIN	
	PM.DT	PUMP CHANGEOVER HOURS	XXXX HRS	
	ROT.P	ROTATE COOLER PUMPS NOW	YES/NO	
	PMP.O	COOLER PUMP OPERATION	X	
	PM.HT	PUMP HIGH TEMP CUT OFF	XX.XF	
	EMM	EMM MODULE INSTALLED	YES/NO	
	CND.T	CND HX TYP 0=RTPF 1=MCHX	0/1	
	MOPS	EXV MOP SET POINT	XX	
	APPR	CONFIG APPROACH SETPOINT	XX	

III. Unit Start-Up (cont)

PRESS ESCAPE KEY TO DISPLAY 'OPT1'. PRESS DOWN ARROW KEY TO DISPLAY 'OPT2'.
PRESS ENTER KEY.

RECORD CONFIGURATION INFORMATION BELOW.

OPTIONS2 (Options Configuration)

SUBMODE	ITEM	ITEM EXPANSION	DISPLAY	ENTRY
OPT2		UNIT OPTIONS 2 CONTROLS		
	CTRL	CONTROL METHOD	X	
	LOAD	LOADING SEQUENCE SELECT	X	
	LLCS	LEAD/LAG CIRCUIT SELECT	X	
	LCWT	HIGH LCW ALERT LIMIT	XX.X ΔF	
	DELY	MINUTES OFF TIME	XX	
	ICE.M	ICE MODE ENABLE	ENBL/DSBL	
	LS.MD	LOW SOUND MODE SELECT	X	
	LS.ST	LOW SOUND START TIME	00:00	
	LS.ND	LOW SOUND END TIME	00:00	
	LS.LT	LOW SOUND CAPACITY LIMIT	XXX %	

PRESS ESCAPE KEY TO DISPLAY 'OPT2'. PRESS DOWN ARROW KEY TO DISPLAY 'CCN'.
PRESS ENTER KEY.

RECORD CONFIGURATION INFORMATION BELOW.

CCN (CCN Network Configuration)

SUB-MODE	ITEM	ITEM EXPANSION	DISPLAY	ENTRY
CCN	CCNA	CCN ADDRESS	XXX	
	CCNB	CCN BUS NUMBER	XXX	
	BAUD	CCN BAUD RATE	X	

CUT ALONG DOTTED LINE

CUT ALONG DOTTED LINE

III. Unit Start-Up (cont)

PRESS ESCAPE KEY TO DISPLAY 'HP.B'. PRESS DOWN ARROW KEY TO DISPLAY 'EXV.A'.
PRESS ENTER KEY.

RECORD CONFIGURATION INFORMATION BELOW.

EXV.A (Circuit A EXV Configuration)

SUB-MODE	ITEM	ITEM EXPANSION	DISPLAY	ENTRY
EXV.A	EXV.L	EXV OPENING AT LOW LWT	XX%	
	LWT.L	LWT FOR EXV MIN OPENING	XX° F	
	EXV.H	EXV OPENING AT HIGH LWT	XX%	
	LWT.H	LWT FOR EXV MAX OPENING	XX° F	
	MIN.A	EXV CIRC.A MIN POSITION	XXX	
	RNG.A	EXVA STEPS IN RANGE	XXXXX	
	SPD.A	EXVA STEPS PER SECOND	XXXXX	
	POFA	EXVA FAIL POSITION IN%	XXX	
	MIN.A	EXVA MINIMUM STEPS	XXXXX	
	MAX.A	EXVA MAXIMUM STEPS	XXXXX	
	OVR.A	EXVA OVERRUN STEPS	XXX	
	TYPA	EXVA STEPPER TYPE	0,1	
	H.SCT	HIGH SCT THRESHOLD	XXX	
	X.PCT	OPEN EXV X% ON 2ND COMP	XX	
	X.PER	MOVE EXV X% ON DISCRSOL	XX	
	A.PCT	PRE-OPEN EXV - FAN ADDING	XXX	
	M.PCT	PRE-CLOSE EXV - FAN SUB	XXX	
	S.PCT	PRE-CLOSE EXV - LAG SHUT	XXX	
	DELY	LAG START DELAY	XXX	
	L.DL.T	LOW SH DELTA T - EXV MOVE	XXX	
SHR.T	EXV RATE THRESHOLD	XX.X ΔF		
L.EX.M	LOW SH OVERRIDE EXV MOVE	X.X%		

PRESS ESCAPE KEY TO DISPLAY 'EXV.A'. PRESS DOWN ARROW KEY TO DISPLAY 'EXV.B'.
PRESS ENTER KEY.

RECORD CONFIGURATION INFORMATION BELOW.

EXV.B (Circuit B EXV Configuration)

SUB-MODE	ITEM	ITEM EXPANSION	DISPLAY	ENTRY
EXV.B	MIN.B	EXV CIRC.B MIN POSITION	XXX	
	RNG.B	EXVB STEPS IN RANGE	XXXXX	
	SPD.B	EXVB STEPS PER SECOND	XXXXX	
	POFB	EXVB FAIL POSITION IN %	XXX	
	MIN.B	EXVB MINIMUM STEPS	XXXXX	
	MAX.B	EXVB MAXIMUM STEPS	XXXXX	
	OVR.B	EXVB OVERRUN STEPS	XXX	
	TYP.B	EXVB STEPPER TYPE	0,1	

III. Unit Start-Up (cont)

PRESS ESCAPE KEY TO DISPLAY 'EXV.B'. PRESS DOWN ARROW KEY TO DISPLAY 'MM'.
PRESS ENTER KEY.

RECORD CONFIGURATION INFORMATION BELOW.

MM (Motormaster Configuration Settings)

SUB-MODE	ITEM	ITEM EXPANSION	DISPLAY	ENTRY
MM	MMR.S	MOTORMASTER SELECT	YES/NO	
	P.GAN	HEAD PRESSURE P GAIN	XX	
	I.GAN	HEAD PRESSURE I GAIN	XX.X	
	D.GAN	HEAD PRESSURE D GAIN	XX.X	
	MIN.S	MINIMUM FAN SPEED	XX	

PRESS ESCAPE KEY TO DISPLAY 'MM'. PRESS DOWN ARROW KEY TO DISPLAY 'RSET'.
PRESS ENTER KEY.

RECORD CONFIGURATION INFORMATION BELOW.

RSET (Reset Configuration Settings)

SUBMODE	ITEM	ITEM EXPANSION	DISPLAY	ENTRY
RSET		RESET COOL TEMP		
	CRST	COOLING RESET TYPE	X	
	MA.DG	4-20 - DEGREES RESET	XX.X ΔF	
	RM.NO	REMOTE - NO RESET TEMP	XXX.X °F	
	RM.F	REMOTE - FULL RESET TEMP	XXX.X °F	
	RM.DG	REMOTE - DEGREES RESET	XX.X ΔF	
	RT.NO	RETURN - NO RESET TEMP	XXX.X ΔF	
	RT.F	RETURN - FULL RESET TEMP	XXX.X ΔF	
	RT.DG	RETURN - DEGREES RESET	XX.X ΔF	
	DMDC	DEMAND LIMIT SELECT	X	
	DM20	DEMAND LIMIT AT 20 MA	XXX %	
	SHNM	LOADSHED GROUP NUMBER	XXX	
	SHDL	LOADSHED DEMAND DELTA	XXX %	
	SHTM	MAXIMUM LOADSHED TIME	XXX	
	DLS1	DEMAND LIMIT SWITCH 1	XXX %	
	DLS2	DEMAND LIMIT SWITCH 2	XXX %	
	LLEN	LEAD/LAG CHILLER ENABLE	ENBL/DSBL	
	MSSL	MASTER/SLAVE SELECT	SLVE/MAST	
	SLVA	SLAVE ADDRESS	XXX	
	LLBL	LEAD/LAG BALANCE SELECT	X	
LLBD	LEAD/LAG BALANCE DELTA	XXX		
LLDY	LAG START DELAY	XXX		
PARA	PARALLEL CONFIGURATION	YES/NO		

CUT ALONG DOTTED LINE

CUT ALONG DOTTED LINE

III. Unit Start-Up (cont)

PRESS ESCAPE KEY TO DISPLAY 'RSET'. PRESS DOWN ARROW KEY TO DISPLAY 'SLCT'.
PRESS ENTER KEY.

RECORD CONFIGURATION INFORMATION BELOW:

SLCT (Setpoint and Ramp Load Configuration)

SUBMODE	ITEM	ITEM EXPANSION	DISPLAY	ENTRY
SLCT		SETPOINT AND RAMP LOAD		
	CLSP	COOLING SETPOINT SELECT	X	
	RL.S	RAMP LOAD SELECT	ENBL/DSBL	
	CRMP	COOLING RAMP LOADING	X.X	
	SCHD	SCHEDULE NUMBER	XX	
	Z.GN	DEADBAND MULTIPLIER	X.X	

PRESS ESCAPE KEY SEVERAL TIMES TO GET TO THE MODE LEVEL (BLANK DISPLAY). USE THE ARROW KEYS TO SCROLL TO THE SET POINT LED. PRESS ENTER TO DISPLAY SETPOINTS.
RECORD CONFIGURATION INFORMATION BELOW:

SETPOINT

SUBMODE	ITEM	ITEM EXPANSION	DISPLAY	ENTRY
COOL		COOLING SETPOINTS		
	CSP.1	COOLING SETPOINT 1	XXX.X °F	
	CSP.2	COOLING SETPOINT 2	XXX.X °F	
	CSP.3	ICE SETPOINT	XXX.X °F	
HEAD		HEAD PRESSURE SETPOINTS		
	H.DP	HEAD SET POINT	XXX.X °F	
	F.ON	FAN ON SET POINT	XXX.X °F	
	F.OFF	FAN OFF SET POINT	XXX.X °F	
	B.OFF	BASE FAN OFF DELTA TEMP	XX.X	
	F.DLT	FAN STAGE DELTA	XX.X	
FRZ		BRINE FREEZE SETPOINT		
	BR.FZ	BRINE FREEZE POINT	XXX.X °F	

III. Unit Start-Up (cont)

COMPONENT TEST

USE ESCAPE/ARROW KEYS TO ILLUMINATE CONFIGURATION LED. PRESS ENTER TO DISPLAY 'DISP'. PRESS ENTER AGAIN TO DISPLAY 'TEST' FOLLOWED BY 'OFF'. PRESS ENTER TO STOP DISPLAY AT 'OFF' AND ENTER AGAIN SO 'OFF' DISPLAY FLASHES. 'PASS' AND 'WORD' WILL FLASH IF PASSWORD NEEDS TO BE ENTERED. PRESS ENTER TO DISPLAY PASSWORD FIELD AND USE THE ENTER KEY FOR EACH OF THE FOUR PASSWORD DIGITS. USE ARROW KEYS IF PASSWORD IS OTHER THAN STANDARD. AT FLASHING 'OFF' DISPLAY, PRESS THE UP ARROW KEY TO DISPLAY 'ON' AND PRESS ENTER. ALL LED SEGMENTS AND MODE LEDS WILL LIGHT UP. PRESS ESCAPE TO STOP THE TEST. PRESS ESCAPE TO RETURN TO THE 'DISP' DISPLAY. PRESS THE ESCAPE KEY AGAIN AND USE THE ARROW KEYS TO ILLUMINATE THE SERVICE TEST LED. PRESS ENTER TO DISPLAY 'TEST'. PRESS ENTER TO STOP DISPLAY AT 'OFF' AND ENTER AGAIN SO 'OFF' FLASHES. PRESS THE UP ARROW KEY AND ENTER TO ENABLE THE MANUAL MODE. PRESS ESCAPE AND DISPLAY NOW SAYS 'TEST' 'ON'. REFER TO THE TABLE BELOW.

Service Test Mode and Sub-Mode Directory

SUB-MODE	KEYPAD ENTRY	ITEM	DISPLAY	ITEM EXPANSION	COMMENT	Completed (Yes/No)
TEST	ENTER		ON/OFF	SERVICE TEST MODE	To Enable Service Test Mode, move Enable/Off/Remote Contact switch to OFF. Change TEST to ON. Move switch to ENABLE.	
OUTS	OUTPUTS AND PUMPS					
	ENTER	EXV.A	xxx%	EXV% OPEN		
	↓	EXV.B	xxx%	EXV% OPEN		
	↓	FAN1	ON/OFF	FAN 1 RELAY	Condenser fan contactor 1	
	↓	FAN2	ON/OFF	FAN 2 RELAY	Condenser fan contactor 2	
	↓	FAN3	ON/OFF	FAN 3 RELAY	Condenser fan contactor 3	
	↓	FAN4	ON/OFF	FAN 4 RELAY	Condenser fan contactor 4	
	↓	FAN5	ON/OFF	FAN 5 RELAY	Condenser fan contactor 5	
	↓	FAN6	ON/OFF	FAN 6 RELAY	Condenser fan contactor 6	
	↓	FAN7	ON/OFF	FAN 7 RELAY	Condenser fan contactor 7	
	↓	FAN8	ON/OFF	FAN 8 RELAY	Condenser fan contactor 8	
	↓	V.HPA	xx	VAR HEAD PRESS% CIRCUIT A		
	↓	V.HPB	xx	VAR HEAD PRESS% CIRCUIT B		
	↓	CLP.1	ON/OFF	COOLER PUMP RELAY 1		
	↓	CLP.2	ON/OFF	COOLER PUMP RELAY 2		
	↓	DIG.P	xxx	COMPRESSOR A1 LOAD PERCENT	Digital Scroll option only	
	↓	CL.HT	ON/OFF	COOLER/PUMP HEATER		
	↓	CCH.A	ON/OFF	CRANKCASE HEATER CIRCUIT A		
	↓	CCH.B	ON/OFF	CRANKCASE HEATER CIRCUIT B		
	↓	RMT.A	ON/OFF	REMOTE ALARM RELAY		

NOTE: If the unit has a single circuit, the Circuit B items will not appear in the display.

CUT ALONG DOTTED LINE

CUT ALONG DOTTED LINE

Service Test Mode and Sub-Mode Directory (cont)

SUB-MODE	KEYPAD ENTRY	ITEM	DISPLAY	ITEM EXPANSION	COMMENT	Completed (Yes/No)
CIRCUIT A COMPRESSOR TEST						
CMPA	ENTER	CC.A1	ON/OFF	COMPRESSOR A1 RELAY		
	↓	DIG.P	0 to 15	COMP A1 UNLOAD PERCENT	Digital Scroll option only	
	↓	CC.A2	ON/OFF	COMPRESSOR A2 RELAY		
	↓	CC.A3	ON/OFF	COMPRESSOR A3 RELAY		
	↓	MLV	ON/OFF	MINIMUM LOAD VALVE RELAY		
CIRCUIT B COMPRESSOR TEST						
CMPB	ENTER	CC.B1	ON/OFF	COMPRESSOR B1 RELAY	See Note	
	↓	CC.B2	ON/OFF	COMPRESSOR B2 RELAY	See Note	
	↓	CC.B3	ON/OFF	COMPRESSOR B3 RELAY	See Note	

NOTE: If the unit has a single circuit, the Circuit B items will not appear in the display.

COMMENTS:

Lined area for handwritten comments.

SIGNATURES:

START-UP
TECHNICIAN _____

CUSTOMER
REPRESENTATIVE _____

DATE _____

DATE _____

CUT ALONG DOTTED LINE

CUT ALONG DOTTED LINE

DIVISION 26

ELECTRICAL

PART 1 – GENERAL

- 1.1 This section is intended to supplement or modify the conditions and requirements defined in the General or Project Requirements given in the General Requirements of this specification. The General Requirements and this Section shall apply to all electrical work as described in Electrical Specification Sections 26 00 00 through 26 09 99.
- 1.2 WORK COVERED BY CONTRACT DOCUMENTS
- A. All work, materials, etc., shall be furnished and installed, whether or not specifically shown on the drawings and/or called for in the specifications, which may be necessary to comply with all of the requirements, due to the exigencies of the work, to complete the work and the contract in a satisfactory and approved manner.
 - B. The work to be done under this contract shall consist of furnishing all equipment, labor, materials required for the items listed in the proposal, and/or as shown on the contract drawings, together with all devices, connectors, splices and appurtenances, required for a safe, clean, complete and ready for service, reliable, substantial and rugged working installation, to the satisfaction of the Engineer and to execute the intent of this contract and these specifications.
 - C. The Contractor shall be responsible for determining the proper connection points for all power, control, and signal wiring installed under this contract, regardless of whether the connection points are in equipment furnished under this contract, existing equipment, or equipment furnished by others. The Contractor shall include in his bid prices any field surveys, wire tracing or other work required to ascertain the proper connection points for all wiring.
 - D. It is the intent of these specifications that the Contractor shall furnish equipment and material which is suitable for the purpose and for installation in the location as specified, and which is adequate and satisfactory for the service intended.
 - E. It is also the intent of the specification that the equipment, materials and accessories, as furnished, shall be complete in all respect and ready to operate.
 - F. The specifications cover the general design, construction arrangement, and certain particular features, but do not purport to cover all details entering into the design of the equipment and accessories.
 - G. Minor revisions in construction details will be made to accommodate equipment proposed and approved on the drawings thereof, submitted by the Contractor. Major revisions shall not be made nor shall equipment be submitted for approval which cannot be installed in structures of the approximate dimensions and character specified herein.
 - H. Further, it is also the intent of these specifications to provide a complete contract including items which may be omitted or not shown but which are considered normal and accepted engineering practice for this type of contract at no additional cost to the Owner.
 - I. All work shall be done in a thorough and workmanlike manner and shall conform to the best modern practice in the manufacture and installation of high-grade equipment and materials. Wherever possible, all parts shall be made according to standard gauge to facilitate replacement and repair.
 - J. All materials furnished under these items shall be the best of their respective kinds and shall be free from defects in design and workmanship.

- K. All materials or equipment not meeting the specified requirements shall be rejected and shall be replaced at once by the Contractor with materials or equipment of the specified type and quality, at no cost to the Owner.
- L. All materials for which no detailed specifications are given herein shall be of the quality and character best adapted and suitable for the purpose for which they are to be used and shall be subject to the approval of the Engineer.
- M. Where any material or article or the maker or distributor thereof is specified by name, this is done for the purpose of more clearly describing the type or quality desired. Any material or article of equal quality, merit and performance, in the opinion of the Engineer, will be acceptable, if approval is given in writing.
- N. All materials furnished and work done by the Contractor shall be subject to the inspection of the Engineer. Defective materials shall be removed from the site of the work and defective work repaired or replaced as directed. Facilities for handling and inspection of materials and equipment and for access to the work in progress, shall at all times be furnished by the Contractor.
- O. Where any delay is encountered in carrying out work due to unfavorable operating conditions, the Contractor shall not be entitled to additional compensation therefore, but the time allowed equivalent to the period of actual delay.

1.3 DESCRIPTION OF WORK

- A. Work includes all labor, equipment, wiring, termination, testing and documentation to satisfy the design intend described in the contract documents for all electrical, tele/data and lighting systems in the building to the satisfaction of the Engineer.
- B. Unless specifically dimensioned, the work shown on the drawings is diagrammatic, and is intended only to show general arrangement.
- C. Include in the work, all accessories and devices necessary for the intended operation or perfection of any system, whether or not specifically shown or specified.
- D. The term "Furnish" shall mean to obtain and supply to the job site. The term "Install" shall generally mean to fix in position and connect for use. Where language indicates that one party or trade is to "install" and another is to "connect", the term "install" shall mean only to fix in position, and "connect" shall mean to make electrical connections to. The term "Provide" shall mean to furnish and install.
- E. Testing & Start-Up:
 - 1. Start-up & test each component of all building systems covered by the contract documents.

1.4 STANDARD OF QUALITY

- A. The specifications establish the standards of quality required, either by description or by references, to brand name, name of manufacturers or manufacturer's model number. All materials shall be new unless noted otherwise.
- B. Where one or multiple products are specifically identified by name or manufacturer's model number, the cited examples are used only to denote the quality standard of the product desired and they do not restrict the contractor to a specific brand, make, manufacturer or specific name. They are used only to set forth and convey to bidders the general style, type, character and quality of product desired. The function, performance and quality of the specified item shall meet the criteria set forth. Equivalent or better products will be acceptable unless an item is specifically identified on the bid sheet as an owner-preferred alternate item in compliance with NC. G.S. 133.3.

- C. The Contractor may submit, with his bid, the names of products which are proposed as substitutions for products named in the specifications. Each proposed substitution shall be accompanied by a written sum of money to be added or deducted from his bid. The Owner reserves the sole right to accept or reject said substitutions with or without cause.
- D. When equipment and/or materials are proposed to be purchased from a manufacturer other than those specified, the Contractor shall provide complete data adequate for the Engineer's evaluation of the proposed substitution.
- E. When the equipment other than that specified is used, the Contractor shall be responsible for any extra cost of required revisions such as structural steel, concrete, electrical, piping, etc. Such additional costs shall be identified at the time such substitutions are proposed.

1.5 SUBMITTALS

- A. Engineers review of shop drawings is solely for the benefit of the Owner and in no way relieves the contractor from his obligations to furnish materials which satisfy the requirements of his contract and the design intent.
- B. Shop drawings, product data and samples shall be submitted as required by the General Conditions or Project Requirements and as supplemented by this section.
- C. When a specific specification section identifies that no submittal is required, the contractor shall provide the specified materials without submittals.
- D. Provide to the Engineer, a schedule of shop drawing submissions identifying submittal target dates.
- E. The Contractor shall review, approve and submit shop drawings, with promptness so as to cause no delay in his work or in that of others. No submissions will be accepted by the Engineer without the signed review and approval of the Contractor.
- F. The Contractor shall check and verify pertinent field measurements, and quantities of equipment and materials required.
- G. Submittals shall be identified by reference to the drawing(s), section(s) of specifications, or equipment symbols to which they relate.
- H. Shop drawings, when required, shall include:
 1. Verification of information given in Contract Documents such as performance, dimensions, weight, materials, construction, types, models, manufacturer, etc.
 2. Equipment layouts drawn to scale as may be required.
 3. Wiring diagrams and schematics for equipment.
 4. Any special construction conditions.
 5. Other information/data as may be requested.
- I. All submittals shall identify the specific details of the product or assembly. All optional features being provided or proposed shall be so noted or the submittal will be rejected.
- J. The Engineer will return submittals with one of the following notations stamped thereon; REVIEWED, REVIEWED AS NOTED, REVISE AND RESUBMIT, REJECTED or SUBMIT SPECIFIED ITEM AND THE FOLLOWING:
 1. Review is only for general conformance with the design concept of the project and general compliance with the information given in the contract documents. Any action shown is subject to the requirements of the plans and specifications. Contractor is responsible for: dimensions which shall be

confirmed and correlated at the job site; fabrication processes and techniques of construction; coordination of his work with that of all other trades; and the satisfactory performance of his work.

2. The work involved may proceed when submittals are marked REVIEWED or NO EXCEPTIONS TAKEN with no further submission required.
3. The work involved may proceed when submittals are marked REVIEWED AS NOTED providing corrections are made and submittals are resubmitted for record. Review does not authorize changes to Contract Sum unless stated in a separate letter or Change Order. If any notes placed on the submittals by the Engineer are believed to result in a change in the Contract Sum, the Engineer shall be notified immediately, and fabrication may not be undertaken until written authorization to proceed is issued by the Owner.
4. The work involved may not proceed when submittals are marked REVISE AND RESUBMIT. Submittals must be corrected and resubmitted for review.
5. Submittals marked REJECTED OR SUBMIT SPECIFIED ITEM are not in accordance with the Contract Documents and require a new submittal for review.

K. For items being resubmitted, clearly identify changes made from the initial submittal requested by the Engineer. The Engineer will review only those changes requested and identified by the Contractor.

1.6 PROTECTION OF WORK

- A. Each Contractor is responsible for the protection of his materials, equipment, and completed work as defined in the General or Project Requirements and as supplemented herein.
- B. All openings into any part of the conduit systems, all fixtures and equipment must be securely covered or otherwise protected to prevent damage due to dropped tools or materials, work by others or intrusion of grit, dirt, water, snow, ice or other foreign matter. Remove burrs, dirt, paint spots and debris. The Contractor shall be held responsible for all damage done to unprotected work or materials.
- C. All equipment on site, whether stored or installed, shall be protected with weather tight covers.

1.7 STEEL AND CONCRETE WORK FOR ELECTRICAL EQUIPMENT

A. Steel

1. Provide all miscellaneous steel supports and anchors required for equipment and materials installed under this Specification. Manual of Construction by American Institute of Steel Construction latest edition shall be followed in design and construction except that the second sentence of paragraph 4.2.1., Section 4 of Division 5, page 5-177 will not apply. Structural steel members shall conform to ASTM A36, and shall have a shop applied coat of rust inhibiting paint.
2. Welding of steel shall conform to American Welding Society, Standard Code for Arc and Gas Welding in Building Construction.
3. Bolts, nuts and washers for structural steel framing and concrete embedment shall be high tensile type minimum 3/4" diameter conforming to ASTM A325.

B. Slotted-steel channel supports shall have flange edges turned toward web, and 9/16-inch diameter slotted holes at a maximum 2 inches o.c., in webs. Channel depth: 2-1/2 inches minimum. Channel thickness: selected to suit structural loading. Fittings and Accessories: Products of the same channel manufacturer. Channel supports and fittings shall be hot dip galvanized steel.

C. Concrete work and anchors

1. Refer to Section 260050 and Division 03 for concrete work and anchors.

1.8 COUNTERFLASHING

- A. Where conduits or other items pass through any roof, wall or other exterior component, provide counter flashing as required.

1.9 EQUIPMENT BY OTHERS

- A. Section - Summary of Work, together with other technical sections in the Project Manual, describe equipment that will be furnished by the Owner or from other sources.
- B. The responsibility for setting, installation and protection of such equipment will be defined in other sections of the Project Manual.
- C. Provide services rough-in for and make final connections to this equipment as shown and specified.
- D. Provide coordination to assure clearances required for moving equipment to final location.

1.10 MOVING AND INSTALLATION OF RACEWAYS, DEVICES AND EQUIPMENT

- A. Verify that electrical equipment will pass through all restricting openings, and when equipment or sections of equipment are larger than these openings, install this equipment prior to construction of enclosing walls, floors or roofs.
- B. Use planking or cribbing as required to protect adjoining construction from damage.
- C. Provide rigging and scaffolding with expert rigging / scaffolding personnel as required for equipment installation in difficult locations. Rigging & scaffolding shall include any necessary structural investigation and temporary structural support.

1.11 CUTTING AND PATCHING

- A. Provide all openings through walls, floors and ceilings, etc. required for the installation of work defined on the drawings and specifications.
- B. Following installation and testing, restore floors, walls and ceilings with materials equal to the original construction and finish to match existing surfaces.
- C. Cutting and patching shall be performed only by tradesmen familiar with the construction involved.

1.12 IDENTIFICATION

- A. Refer to Section 26 01 95.

1.13 FINAL ACCEPTANCE

- A. The Contractor shall perform and complete work in accordance with the Contract Documents without fault or defect of any kind. In the absence of more specific directives, the work shall:
 - 1. Be completed in a first-class manner.
 - 2. Be placed in a thoroughly clean and unmarred condition.
 - 3. Be checked out in a step-by-step manner to ascertain that fastenings, controls, parts, safety devices, operating devices and other required appurtenances have been provided in accordance with the Contract Documents.
 - 4. Be free of previously condemned or rejected parts and be properly restored to an acceptable condition.
 - 5. Be adjusted for proper operation wherever adjustments or calibrations exist in the work.
 - 6. All systems shall be operated to demonstrate that the requirements of the Contract have been met and that the systems have been adjusted and will operate in accordance therewith.

1.14 OPERATING AND MAINTENANCE INSTRUCTIONS

- A. Furnish for review, three hard bound copies of complete written instructions for the operation, care and maintenance of each piece of equipment and/or system. Include recommended frequency of inspection, cleaning, oiling, greasing, and adjustment and other action as may be required in accordance with manufacturer's recommendations. Material shall include manufacturer's brochures, catalog cuts, parts lists, wiring diagrams, service organizations, etc.

1.15 PERMITS, FEES AND CERTIFICATES OF APPROVAL

- A. Contractor shall acquire all required permits and certificates. Inspection fees fixed by counties and municipalities shall not be applicable per GS143-135.1.
- B. Contractor shall provide all power, labor and instruments required for tests and cleaning of systems.
- C. Whenever tests are required, three (3) copies of the test reports shall be submitted to the Engineer.
- D. Tests may be observed by the Engineer or his representative. Notify the Engineer a minimum of three weeks in advance of test dates.

1.16 COMPLIANCE WITH CODES, STANDARDS AND REGULATIONS

- A. In the absence of specific instruction in the technical specifications, equipment and installation shall conform to the following applicable codes, standards and regulations, latest editions:
 - 1. American Society for Testing and Materials (ASTM)
 - 2. American National Standard Institute (ANSI)
 - 3. Underwriter's Laboratories, Inc. (UL)
 - 4. American Welding Society Code (AWSC)
 - 5. NFPA 70, "National Electrical Code", latest edition
 - 6. National Electrical Manufacturer's Association (NEMA).
 - 7. Occupational Safety and Health Act (OSHA).
 - 8. National Fire Protection Association (NFPA).
 - 9. National Electrical Safety Code (NESC)
 - 10. North Carolina State Building Code. (NCSBC)
 - 11. Institute of Electrical and Electronics Engineers (IEEE)
 - 12. Illuminating Engineering Society of North American (IESNA)
 - 13. State and Local Building, Electric, and Fire Codes and Regulations.

1.17 PAINTING

- A. Cabinet trims and similar prefabricated equipment shall be factory primed and finish painted with baked enamel in color selected. This equipment shall not be painted in the field unless the factory finishes have been marred or as otherwise directed. Do not paint over UL or similar labels or mechanical/electrical nameplates.
- B. Exposed conduit visible to the public shall be painted to match adjacent finish. Prime conduits for better adhesion of paint.

1.18 COORDINATION OF WORK

- A. Coordinate installation of conduit runs and equipment with other trades and conditions in the building and participate in all coordinated shop drawings. Variance from work shown on drawings will be subject to approval. Where interference occurs and electrical work is directed to be relocated, provide such relocation without additional cost.

1.19 LOCATION OF OUTLETS

- A. Examine all architectural and vendor drawings before locating outlets. Place outlets as required to harmonize with moldings, panels, cabinets, mirrors, etc. Do not scale dimensions on electrical drawings but use measurements from architectural drawings.
- B. If an outlet is installed in such a location as to be out of proper relation to beams, walls, or other details of the building, relocate the outlet as directed. A relocation allowance of 10 ft. shall be understood by the Contractor with no extra cost to the Owner.
- C. Unless otherwise indicated, outlet boxes in walls shall be located with center line at the following elevation above the Finish floor line. Verify with Contractor for General Construction, all heights prior to actual layout of work.
 - 1. Switch Outlets 3 feet - 10 inches
 - 2. Bracket Outlets (Stairs) 7 feet - 0 inches
 - 3. Bracket Outlets (Other) 6 feet - 6 inches
 - 4. Telephone Outlets (Wall) 4 feet - 1 inch
 - 5. Telephone and Data Outlets (Other) 1 foot - 6 inches. Unless otherwise noted
 - 6. Receptacle Outlets 1 foot - 6 inches. Unless otherwise noted.
 - 7. Receptacle Outlets 3 feet - 0 inches in Mechanical Rooms
 - 10. Motor Starters and Safety Switches 4 feet - 0 inches to 6 feet - 0 inches as required
 - 11. Panel Boards (top) 6 feet - 0 inches

1.20 ACCESS PANELS

- A. Furnish access panels where required, to concealed pull boxes, junction boxes, or similar equipment located above dry wall board ceiling or behind walls. Installation of access panels shall be by mechanics of the pertinent trade under General Construction.
- B. Access panels shall be 18" x 18" minimum, 16 gage wall or ceiling frame and a 14-gage panel door with not less than 1/8" fire proofing secured to the inside of the door. The door shall be provided with concealed hinges and cylinder lock, and prime-coated steel prepared for painting. Each door shall be capable of opening 180 degrees. Doors for wall panels shall be secured with suitable clips and counter sunk tamperproof screws.
- C. Access panels shall have "label" fire rating equal to the ceiling or wall surface.

1.21 WARRANTY

- A. The contractor and equipment manufacturers shall jointly guarantee all wiring and equipment to be free of defects in workmanship and material for a period of one year from the date of final acceptance, unless otherwise noted.

1.22 PROJECT RECORD DOCUMENTS

- A. Maintain at job site, one copy of record documents and samples as required under the General Conditions of the Contract, including Drawings, Specifications, Addenda and Bulletins, Change Orders, Shop Drawings, Product Data and Samples, Field Orders, Field Test Records and Maintenance and Operating Manuals.
- B. Provide files and racks for storage of documents. Maintain documents in a clean, dry legible condition and in good order. Do not use record documents for construction purposes. Make record documents and samples available during normal working hours for inspection.
- C. Recording:

1. Label each document "Project Record" in neat large letters and provide final completion date.
 2. Record information concurrently with construction progress.
 3. Do not conceal any work until required information is recorded.
- D. Record Drawings - legibly mark to record actual construction as follows:
1. A print set (blue-line or black-line) of contract drawing or shop drawing mark-ups of actual installations which vary substantially from the work as originally shown. Mark whichever drawing is most capable of showing "field" condition fully and accurately; however, where shop drawing are used for mark-up, record a cross reference at corresponding location on working drawings. Mark with red erasable pencil and, where feasible, use other colors to distinguish between variation in separate categories or work. Mark-up new information which is recognized to be of importance to Owner, but was for some reason not shown on either contract drawings or shop drawings. Give particular attention to concealed work which would be difficult to measure and record at a later date. Note related change order numbers where applicable.
- E. Record Specifications and Addenda, Bulletins, Requests for Information (RFI's) and Construction Clarification Sketches (CSK's) - legibly mark each Section to record:
1. Any variations in actual work in comparison with text of specifications and modifications as issued. Give particular attention to substitutions, selection of options, and similar information work where it is concealed or cannot otherwise be readily discerned at a later date by direct observations. Note related record drawing information and product data, where applicable.
 2. Changes made by Field Order or by Change Order.
- F. Product Data: Maintain one copy of each product data submittal, and mark-up significant variation in actual work in comparison with submitted information.
1. Include both variations in product as delivered to site, and variations from manufacturer's instruction and recommendations for installation.
 2. Give particular attention to concealed products and portions of the work which cannot otherwise be readily discerned at a later date by direct observations. Note related change orders and mark-up of record drawings and specifications.
- G. Record Drawings Submittal at Project Completion: Organize record drawing sheets into manageable sets, bind with durable paper cover sheets and print suitable titles, dates and other identification on cover of each set. Transfer marking required by previous paragraphs to set of reproducible transparencies. Submit complete set of transparencies to the Design Professional and two sets of blue-line prints.
- H. Product Data Submittal at Project Completion: Submit three sets of marked-up product data submittals for record purposes that include resolution of all review notes and field revisions.
- I. Record Sample Submittals: Immediately prior to date of substantial completion Design Professional (and including Owner's personnel where desired) will meet with Contractor at site and will determine which if any of submitted samples maintained by Contractor during progress of work are to be transmitted to Owner for record purposes. Comply with Design Professionals instruction for packaging, identification marking, and delivery to Owner's sample storage space.
- J. Miscellaneous Record Submittals: Refer to other sections of these specification for requirements of miscellaneous record-keeping and submittals in connection with actual performance of the work. Immediately prior to date(s) of substantial completion, complete miscellaneous records and place in good order properly identified and bound or filed, ready for continued use and reference. Submit to Architect/Engineer for Owner's records.
- K. Maintenance Manuals: Organize maintenance-and-operating manual information into three suitable sets of manageable size and bind into individual binders properly identified and indexed (thumb-tabbed).

Include: emergency instructions; spare parts listing; warranties; wiring diagrams; recommended "turn-around" cycles; inspection and cleaning procedures; recommended frequency of testing, adjustment and any other maintenance requirements; shop drawings; product data; and similarly, applicable information. Bind each manual of each set-in heavy duty 2-inch, vinyl-covered ring binder, and include pocket folders for folded sheet information. Mark identification on both front and spine for each binder.

END OF SECTION 26 00 00

PART 1 - GENERAL

1.1 SCOPE

- A. This Contractor shall provide all materials, equipment and labor necessary to install and set into operation the electrical equipment as shown on the Engineering Drawings and as contained herein.

1.2 REFERENCES

- A. NCBC: North Carolina Building Code Council.
- B. NCCSB: North Carolina State Building Code
- C. NEC: National Electrical Code (NFPA 70)

1.3 QUALITY ASSURANCE

- A. See the General and Supplementary General Conditions and Division 1.
- B. Work shall be in accordance with the 2020 edition of the North Carolina State Building Code, and the 2020 edition of the National Electrical Code (NFPA 70).
- C. The Contractor shall be responsible for notifying the State Electrical Inspectors in the Construction Administration Section of the State Construction Office to schedule required inspections as work progresses. Schedule electrical inspections for Monday through Friday
- D. Wherever the words "Approved", Approval", and "Approved Equal" appear, it is intended that items other than the model numbers specified shall be subject to the approval of the Engineer.
- E. "Provide" as used herein shall mean that the Contractor responsible shall furnish and install said item or equipment. "Furnish" as used herein shall mean that the contractor responsible shall acquire and make available said item or equipment and that installation shall be by others. "Install" as used herein shall mean that the Contractor responsible shall make installation of items or equipment furnished by others.
- F. All material and equipment that the Contractor proposes to substitute in lieu of those specified shall be submitted to the Engineer ten (10) days prior to the bid date for evaluation. The submittal shall include a full description of the material or equipment and all pertinent engineering data required to substantiate the equality of the proposed item to that specified. Items that are submitted for approval after this date will not be accepted. Substitute material and equipment will not be deemed to be approved until notification is given in a written addendum prior to the bid date.
- G. All materials and equipment shall comply with NEMA 250 standard as follows:
 - 1. Interior Dry Locations in Production Areas: Type 12
 - 2. Interior Dry Locations in Non-Production Areas: Type 1.
 - 3. Exterior, Wet and Damp Locations: Type 3R.

1.4 SUBMITTALS

- A. See General and Supplementary General Conditions & Division 1.

- B. Within twenty (20) days after notification of the award of the contract and written notice to begin work, the Contractor shall submit for approval to the Architect/Engineer a detailed list of equipment and materials, which he proposes to use. Items requiring submittal data for approval will be noted at this time. One electronic set of submittal data shall be provided in pdf format for approval.
- C. Each submittal shall bear the approval of the contractor indicating that he has reviewed the data and found it to meet the requirements of the drawings and specifications as well as space limitations and other project conditions, before submittal to the Engineer for review. The submittals shall be clearly identified showing project name, manufacturer's catalog number and all necessary performance and fabrication data. All requirements, parameters, information, details and other information noted about submitted equipment in the specifications and on the drawings shall be specifically addressed in the submittal. Submittals that do not contain this information will be returned to the contractor for resubmittal. The same detailed submittal data shall be provided when items are to be considered as substitution for specified items. Acceptance for approval shall be in writing from the Engineer.
- D. Upon completion of the project, the Contractor shall submit to the Engineer a set of accurately marked-up plans indicating all changes encountered during the construction. These drawings shall remain on the project for its duration and shall be updated at the time changes are made. Final payment will be contingent on receipt of these "Record Drawings."
- E. The Contractor shall furnish four (4) bound sets of maintenance and operating instructions, parts lists, electrical circuit wiring diagrams, all submittal data, and sufficient manufacturer's literature to operate and maintain all equipment.
- F. The Contractor shall submit to the Engineer a duplicate set of final electrical inspection certificates prior to final payment.

1.5 PRODUCT DELIVERY, STORAGE AND HANDLING

- A. All material and equipment shall be delivered and unloaded by the Contractor within the project site as noted herein or as directed by the Owner.
- B. The Contractor shall protect all material and equipment from breakage, theft or weather damage. No material or equipment shall be stored on the ground. Any broken, damaged or weather damaged material or equipment shall be removed from the project site and replaced at the contractor's expense before installation.
- C. The material and equipment shall remain the property of the Contractor until the project has been completed and turned over to the Owner.

1.6 WORK CONDITIONS AND COORDINATION

- A. Safety switches built in to equipment shall be furnished by the contractor furnishing the equipment. The electrical contractor shall furnish safety switches not built in to equipment. The electrical contractor shall review the plans and specifications of other trades to verify whether safety switches are furnished with equipment.
- B. All starters shall be furnished by the contractor furnishing the equipment.
- C. The electrical contractor shall provide power wiring to, a termination point consisting of a junction box, trough or gutter, starter or safety switch. The electrical contractor shall also furnish junction boxes, troughs and gutters. Final connections of the raceways and wire from those termination points to the equipment, except for food service equipment, shall be by the contractor furnishing the equipment. Final connections to food service equipment shall be by the electrical contractor.

- D. Pipe, conduit and duct chases required for installation of work shall be provided by the General Contractor unless otherwise noted. This Contractor shall be responsible for coordinating the location of all required chases.
- E. All work shall be coordinated with other trades. Cutting of new work, due to this contractor's negligence, and subsequent patching shall be approved by the Architect/Engineer and shall be at this contractor's expense with no extra cost to the Owner.

1.7 GUARANTEE

- A. See the General and Supplementary General Conditions.
- B. Where extended warranties or guarantees are available from the manufacturer, the Contractor shall prepare the necessary contract documents to validate these warranties as required by the manufacturer and present them to the Owner.

1.8 REGULATORY REQUIREMENTS

- A. Conform to requirements of ANSI/NFPA 70.
- B. Furnish products listed and classified by third party agencies accredited by the NCBCC to label electrical and mechanical equipment as suitable for purpose specified and shown, where such listing exists.

PART 2 - PRODUCT

- 2.1 Materials and equipment shall be new, unless noted otherwise, of the highest grade and quality and free from defects or other imperfections. Materials and equipment found defective shall be removed and replaced at the Contractor's expense.

PART 3 - EXECUTION

3.1 INSPECTION

- A. If any part of this Contractor's work is dependent for its proper execution or for its subsequent efficiency or appearance on the character or conditions of contiguous work not executed by him, the Contractor shall examine and measure such contiguous work and report to the Architect/Engineer in writing any imperfection therein, or conditions that render it unsuitable for the reception of this work. Should the Contractor proceed without making such written report, he shall be held to have accepted such work and the existing conditions and he shall be responsible for any defects in this work consequent thereon and will not be relieved of the obligation of any guarantee because of any such imperfection or condition.

3.2 INSTALLATION

- A. All work shall be performed in a manner indicating proficiency in the trade.
- B. All conduit, pipes, ducts, etc., shall be either parallel to building walls or plumb where installed in a vertical position and shall be concealed when located in architecturally finished areas.
- C. Any cutting or patching required for installation of this Contractor's work shall be kept to a minimum. The Architect/Engineer shall require written approval if cutting of primary structure is involved.
- D. All patching shall be done in such a manner as to restore the areas or surfaces to match existing finishes.
- E. The Contractor shall lay out and install his work in advance of pouring concrete floors or walls. He shall furnish and install all sleeves or openings through poured masonry floors or walls above grade required for passage of all conduits, pipes or duct installed by him. The Contractor shall furnish and install all inserts and hangers required to support equipment.

F. Grounding:

1. The main service shall be grounded to a ground bar and to the service side of domestic water main (and Fire Main if used) sized per NEC Table 250.102(C)(1) and to building steel and pad rebar with #2.
2. The secondary neutral of each dry type transformer shall be bonded to the conduit system/transformer enclosure primary feeder ground wire, and building steel (where available).
3. A grounding conductor sized per NEC Table 250.122 shall be installed in all raceways containing power conductors.
4. Communications/Data service to have local ground bar bonded to service ground bar with #6.
5. Exterior metallic fencing shall be exothermically bonded with #6 to building steel. Gates shall have #6 at 24" BFG from post to post. Welds shall be at grade.
6. Bond natural gas pipe, to service ground bar, in visible, accessible location.
7. Bond #6 across all valves and devices in domestic water service (from source to load side). Bond all branches.

3.3 PERFORMANCE

- A. The Contractor shall perform all excavation and backfill operations necessary for installation of his work.

3.4 ERECTION

- A. All support steel, angles, channels, pipes or structural steel stands and anchoring devices that may be required to rigidly support or this Contractor shall provide anchor material and equipment.

3.5 ADJUST AND CLEAN

- A. All equipment and installed materials shall be thoroughly clean and free of all dirt, oil, grit, grease, etc.
- B. Factory painted equipment shall not be repaired unless damaged areas exist. The manufacturer shall touch up these areas with a material suitable for the intended service so that the finish is equal to that provided. In no event shall nameplates be painted.
- C. At a scheduled meeting, the Contractor shall instruct the Owner or the Owner's representative in the operation and maintenance of all equipment installed under his contract, (in the presence of the Engineer).

END OF SECTION 26 00 10

PART 1 - GENERAL

1.1 SECTION INCLUDES

- A. Metal conduit.
- B. Flexible metal conduit.
- C. Liquid tight flexible metal conduit.
- D. Electrical metallic tubing.
- E. Nonmetallic conduit.
- F. Fittings and conduit bodies.
- G. Electrical nonmetallic tubing.
- H. Surface metal raceway

1.2 RELATED SECTIONS

- A. Drawings and general provisions of the Contract, including General and Supplementary Conditions, Division 1 Specifications and other Division 260 Specification Section, apply to this Section.

1.3 REFERENCES

- A. ANSI C80.1 Rigid Steel Conduit, Zinc Coated.
- B. ANSI C80.3 Electrical Metallic Tubing, Zinc Coated.
- C. ANSI/NEMA FB 1 Fittings, Cast Metal Boxes, and Conduit Bodies for Conduit and Cable Assemblies.
- D. ANSI/NFPA 70 National Electrical Code.
- E. NECA "Standard of Installation."
- F. NEMA TC 3 PVC Fittings for Use with Rigid PVC Conduit and Tubing.

1.4 DESIGN REQUIREMENTS

- A. Conduit Size: ANSI/NFPA 70.

1.5 SUBMITTALS

- A. Submit under provisions of Section 260010.
- B. Product Data: Provide for metallic conduit, flexible metal conduit, liquid tight flexible metal conduit, metallic tubing, nonmetallic conduit, nonmetallic tubing, fittings and conduit bodies.

1.6 PROJECT RECORD DOCUMENTS

- A. Submit under provisions of Section 260010.
- B. Accurately record actual routing of conduits larger than 1½” inch.

1.7 REGULATORY REQUIREMENTS

- A. Conform to requirements of ANSI/NFPA 70.
- B. Furnish products listed and classified by third party agencies accredited by the NCBCB to label electrical and mechanical equipment as suitable for purpose specified and shown, where such listing exists.

1.8 DELIVERY, STORAGE, AND HANDLING

- A. Accept conduit on site. Inspect for damage.
- B. Protect conduit from corrosion and entrance of debris by storing above grade. Provide appropriate covering.
- C. Protect PVC conduit from sunlight.

1.9 PROJECT CONDITIONS

- A. Verify that field measurements are as shown on Drawings.
- B. Verify routing and termination locations of conduit prior to roughin.
- C. Conduit routing is shown on Drawings in approximate locations unless dimensioned. Route as required completing wiring system.

PART 2 - PRODUCTS

2.1 CONDUIT REQUIREMENTS

- A. Minimum Size: ½” trade size unless otherwise noted.

2.2 METAL CONDUIT

- A. Rigid Steel Conduit: ANSI C80.1.
- B. Intermediate Metal Conduit (IMC): Rigid steel.
- C. Fittings and Conduit Bodies: ANSI/NEMA FB 1; all steel, plated, hexagonal, compression type fittings. Pot metal, setscrew or indenter type fittings will not be accepted.
- D. IMC and rigid conduit shall terminate with either a double locknut/bushing set, or in a threaded hub.

2.3 FLEXIBLE METAL CONDUIT

- A. Description: Interlocked steel or aluminum construction.
- B. Fittings: ANSI/NEMA FB 1.
- C. Sizes: ½” and larger are acceptable for motor, appliance and fixture connections provided a green grounding conductor is installed. The grounding conductor and the flexible conduit size shall meet NEC requirements.

2.4 LIQUID TIGHT FLEXIBLE METAL CONDUIT

- A. Description: Interlocked steel construction with PVC jacket with integral copper grounding conductor.
- B. Fittings: ANSI/NEMA FB 1.
- C. Sizes: ½” and larger are acceptable for motor, appliance and fixture connections provided a green grounding conductor is installed. The grounding conductor and the flexible conduit size shall meet NEC requirements.

2.5 ELECTRICAL METALLIC TUBING (EMT)

- A. Description: ANSI C80.3; galvanized tubing.
- B. Fittings and Conduit Bodies: ANSI/NEMA FB 1; all steel, hexagonal compression, insulated throat type. Pot metal, setscrew or indenter type fittings shall not be used. Provide rain tight fittings in damp locations.
- C. Do not install in locations where EMT or fittings will be in contact with earth or underground (in or below slab on grade or in earth); any location where the tubing would be exposed to the elements; or where exposed to severe corrosive influence and/or severe physical damage.

2.6 NONMETALLIC CONDUIT

- A. Description: NEMA TC 2; Schedule 40 or 80 PVC.
- B. Fittings and Conduit Bodies: NEMA TC 3.

2.7 ELECTRICAL NONMETALLIC TUBING

- A. Description: NEMA TC 2.
- B. Fittings and conduit bodies: NEMA TC 3.

PART 3 - EXECUTION

3.1 CONDUIT USES

- A. Branch circuits run underground external to building foundation walls shall be run in raceways installed in accordance with the NEC and shall be of a type approved by the NEC as “suitable for direct burial.” Minimum raceway size shall be ¾ inch.
- B. Raceways run underground internal to building foundation walls shall be of a type and installed in a method approved by the NEC.
- C. Outdoor Locations, Above Grade: Use rigid steel or intermediate metal conduit.
- D. Wet and Damp Locations: Use rigid steel or intermediate metal conduit.
- E. Dry Locations:
 - 1. Concealed: Use rigid steel or intermediate metal conduit, or electrical metallic tubing.
 - 2. Exposed below 8'0” AFF or to severe physical damage: Use rigid steel or intermediate metal conduit.
 - 3. Exposed above 8'0” AFF and not exposed to severe physical damage in unfinished spaces: Use rigid steel or intermediate metal conduit, or electrical metallic tubing .

4. In finished spaces provide surface metal raceway. In areas below 8'0" provide (2) profiled manufacturer recommended straps for each continuous section of raceway. Coordinate color selection w/ owner.

3.2 INSTALLATION

- A. Install conduit in accordance with NECA "Standard of Installation."
- B. Install nonmetallic conduit in accordance with manufacturer's instructions.
- C. Arrange supports to prevent misalignment during wiring installation.
- D. Support conduit using coated steel or malleable iron straps, layin adjustable hangers, clevis hangers, and split hangers.
- E. Group related conduits; support using conduit rack. Construct rack using steel channel; provide space on each for 25 percent additional conduits.
- F. Fasten conduit supports to building structure and surfaces under provisions of Section 260190.
- G. Do not support conduit with wire or perforated pipe straps. Remove temporary supports.
- H. Do not attach conduit to ceiling support wires.
- I. Arrange conduit to maintain headroom and present neat appearance.
- J. Route exposed and concealed conduit parallel and perpendicular to beams, walls and floors.
- K. Route conduit installed above accessible ceilings parallel and perpendicular to walls.
- L. Route conduit in and under slab from point-to-point.
- M. Maintain adequate clearance between conduit and piping.
- N. Maintain 12-inch clearance between conduit and surfaces with temperatures exceeding 104 degrees F.
- O. Cut conduit square using saw or pipe cutter; deburr cut ends.
- P. Bring conduit to shoulder of fittings; fasten securely.
- Q. Join nonmetallic conduit using cement as recommended by manufacturer. Prepare areas to be joined with appropriate cleaner before applying cement. Wipe nonmetallic conduit dry and clean before joining. Apply full even coat of cement to entire area inserted in fitting. Allow joint to cure for 20 minutes, minimum.
- R. Use conduit hubs to fasten conduit to sheet metal boxes in damp and wet locations and to cast boxes.
- S. Install no more than equivalent of three 90-degree bends between boxes. Use conduit bodies to make sharp changes in direction, as around beams.
- T. Avoid moisture traps; provide junction box with drain fitting at low points in conduit system.
- U. Provide suitable fittings to accommodate expansion and deflection where conduit crosses seismic, control and expansion joints.
- V. Provide suitable pull string, minimum 200-pound breaking strength, in each empty conduit except sleeves and nipples.

- W. Use suitable caps to protect installed conduit against entrance of dirt and moisture.
- X. Ground and bond conduit under provisions of Section 260170.
- Y. Identify conduit under provisions of Section 260195.
- Z. Where raceways pass through a “below grade” wall from a conditioned interior building space, said raceways shall be sealed utilizing fittings similar and equal to OZ/GEDNEY type “FSK” throughwall fitting with “FSKA” membrane clamp adapter, if required.
- AA. Terminate IMC or rigid conduit with a double locknut/bushing set or in a threaded hub.
- BB. Where concentric, eccentric, or oversize knockouts are encountered while terminating conduit of any type, a bonding bushing shall be installed.
- CC. Limit the use of “LBs” to locations only absolutely necessary. Where “LBs” are used, install mogul units above 2 inches.
- DD. Supports for conduit systems shall conform to NEC minimum support requirements.
- EE. Provide a NEC sized green grounding conductor in all conduits.
- FF. Preferred method of installation in finished areas is concealed installation. Cutting and patching of existing surfaces for concealed installation is included. Where permitted by and coordinated with Architect, surface metal raceway may be installed.

3.3 INTERFACE WITH OTHER PRODUCTS

- A. Install conduit to preserve fire resistance rating of partitions and other elements.

3.2 PAINTING

- A. Prime and paint raceway to match adjacent finishes in finished areas.

END OF SECTION 26 01 11

PART 1 - GENERAL

1.1 SECTION INCLUDES

- A. Building wire and cable.
- B. Wiring connectors and connections.

1.2 RELATED SECTIONS

- A. Drawings and general provisions of the Contract, including General and Supplementary Conditions, Division 1 Specifications and other Division 260 Specification Section, apply to this Section.

1.3 REFERENCES

- A. ANSI/NFPA 70 National Electrical Code.

1.4 SUBMITTALS

- A. Submit under provisions of Section 260010.
- B. Manufacturer's Installation Instructions: Indicate application conditions and limitations of use stipulated by product testing agency specified under Regulatory Requirements.

1.5 QUALIFICATIONS

- A. Manufacturer: Company specializing in manufacturing products specified in this Section with minimum three years documented experience.

1.6 REGULATORY REQUIREMENTS

- A. Conform to requirements of ANSI/NFPA 70.
- B. Furnish products listed and classified by third party agencies accredited by the NCBCC to label electrical and mechanical equipment, as suitable for purpose specified and shown, where such listing exists.

1.7 PROJECT CONDITIONS

- A. Verify that field measurements are as shown on Drawings.
- B. Conductors shall be copper.
- C. Wire routing shown on Drawings is approximate unless dimensioned. Route wire as required meeting Project Conditions.
- D. Where wire routing is not shown, and destination only is indicated, determine exact routing and lengths required.

1.8 COORDINATION

- A. Coordinate Work under provisions of Section 260010.

PART 2 - PRODUCTS

2.1 BUILDING WIRE

- A. Description: Single conductor insulated wire.
- B. Insulation Voltage Rating: 600 volts.
- C. Insulation: ANSI/NFPA 70; Type XHHW or THWN/THHN insulation for feeders and branch circuits.
- D. Color Coding:

<u>Phase</u>	<u>208Y/120V</u>	<u>277/480V</u>
A	Black	Brown
B	Red	Orange
C	Blue	Yellow
Neutral	White	Natural Gray
Ground	Green	Green

- E. Wire types and sizes required in other specification sections shall supersede this section.

PART 3 - EXECUTION

3.1 EXAMINATION

- A. Verify that interior of building has been protected from weather.
- B. Verify that mechanical work likely to damage wire has been completed.

3.2 PREPARATION

- A. Completely and thoroughly swab raceway before installing wire.

3.3 WIRING METHODS

- A. All wiring shall be in raceway.
- B. Install a code-gauge green insulated grounding conductor in all raceways.

3.4 INSTALLATION

- A. Install products in accordance with manufacturer's instructions.
- B. Use solid conductors for feeders and branch circuits #10 AWG and smaller. Use Class B stranded conductors #8 AWG and larger.
- C. Use stranded conductors for control circuits.
- D. Use conductors not smaller than 12 AWG for power circuits.
- E. Use conductors not smaller than 14 AWG for control circuits.
- F. Use conductors not larger than 500 kCMIL.
- G. Use 10 AWG conductors to the first outlet for 20 ampere, 120-volt branch circuits longer than 50 feet.

- H. Use 10 AWG conductors to the first outlet for 20 ampere, 277-volt branch circuits longer than 125 feet.
- I. Pull all conductors into raceway at same time.
- J. Use suitable wire pulling lubricant for building wire 4 AWG and larger.
- K. Neatly train and lace wiring inside boxes, equipment, and panelboards.
- L. Clean conductor surfaces before installing lugs and connectors.
- M. Make splices, taps, and terminations to carry full ampacity of conductors with no perceptible temperature rise.
- N. Joints in solid conductors shall be made using Ideal “Wirenuts, 3M Company “Scotchlocks”, T&B “Piggy” or other approved insulated spring, with plastic cap, twist-on connector.
- O. Joints in stranded conductors shall be made using approved mechanical connectors and gum rubber or friction tape with an outer covering of two layers of plastic tape equal to Scotch “33+”. Solderless mechanical connectors for splices and taps, provided with UL approved insulating covers, may be used in place of mechanical connectors and tape.
- P. “StaKon” or other permanent type crimp connectors shall not be used for branch circuit connections.
- Q. Voltage Drop
 - 1. Where the conductor length from the panel to the first outlet on a 277-volt circuit exceeds 125 feet, the branch circuit conductors from the panel to the first outlet shall not be smaller than #10 AWG.
 - 2. Where the conductor length from the panel to the first outlet on a 120-volt circuit exceeds 50 feet, the branch circuit conductors from the panel to the first outlet shall not be smaller than #10 AWG.

3.5 INTERFACE WITH OTHER PRODUCTS

- A. Identify wire under provisions of Section 260195.
- B. Identify each conductor with its circuit number or other designation indicated on Drawings.

3.6 FIELD QUALITY CONTROL

- A. Inspect wire for physical damage and proper connection.
- B. Measure tightness of bolted connections and compare torque measurements with manufacturer's recommended values.

3.7 TESTING

- A. Feeder Insulation Resistance Testing
 - 1. Test all current carrying phase conductors and neutrals as installed, and before connections are made, for insulation resistance and accidental grounds. This shall be done with a 500-volt cable insulation tester. The testing procedures listed below shall be followed:
- B. Minimum readings shall be one million (1,000,000) or more ohms for #6 AWG and smaller wire and 250,000 ohms or more for #4 AWG or larger wire, between phase and neutral conductors, and between phase and neutral conductors and the grounding conductor.
- C. After all devices and equipment are installed and all connections are completed to each panel, the contractor shall disconnect the neutral feeder conductor from the neutral bar and take a cable insulation

tester reading between the neutral bar and the grounded enclosure. If this reading is less than 250,000 ohms, the contractor shall disconnect the branch circuit neutral conductors from this neutral bar. He shall then test each one separately to the panel until the low readings are found. The contractor shall correct the problems, reconnect and retest the wires until at least 250,000 ohms from the neutral bar to the grounded panel can be achieved with only the neutral feeder disconnected.

D. The contractor shall send a letter to the Engineer certifying that the above test has been done, and tabulating the cable insulation tester readings for each panel. This shall be done at least four (4) days prior to final inspection.

E. Ground System Testing

1. Upon completion of installation the electrical grounding and bonding systems, test the ground resistance with a ground resistance tester. Where tests show resistance to ground is over 25 ohms, drive additional ground rods as necessary to reduce the ground resistance to 25 ohms or less. Retest to demonstrate that the resistance is less than or equal to 25 ohms.

F. Documentation

1. All tests specified shall be completely documented indicating time of day, date, temperature and all pertinent test information.
2. At the final inspection, the contractor shall furnish a megger and show the Engineer and local AHJ that the panels comply with the above requirements. He will also furnish a clamp-on type ammeter and a voltmeter and take current and voltage readings as directed by the Engineer and AHJ.
3. All required documentation of readings indicated above shall be submitted to the Engineer prior to, and as one prerequisite for, the final acceptance of the project.

END OF SECTION 26 01 23

PART 1 - GENERAL

1.1 SECTION INCLUDES

- A. Wall and ceiling outlet boxes.
- B. Pull and junction boxes.

1.2 RELATED SECTIONS

- A. Drawings and general provisions of the Contract, including General and Supplementary Conditions, Division 1 Specifications and other Division 260 Specification Section, apply to this Section.

1.3 REFERENCES

- A. NECA Standard of Installation.
- B. NEMA FB 1 Fitting and Supports for Conduit and Cable Assemblies.
- C. NEMA OS 1 Sheet Steel Outlet Boxes, Device Boxes, Covers, and Box Supports.
- D. NEMA 250 Enclosures for Electrical Equipment (1000 Volts Maximum).
- E. NFPA 70 National Electrical Code.

1.4 SUBMITTALS FOR CLOSEOUT

- A. Record actual locations and mounting heights of outlet, pull, and junction boxes on project record documents.

1.5 REGULATORY REQUIREMENTS

- A. Conform to requirements of NFPA 70.
- B. Provide Products listed and classified by third party agencies accredited by the NCBCC to label electrical and mechanical equipment, as suitable for the purpose specified and indicated, where such listing exists.

PART 2 - PRODUCTS

2.1 OUTLET BOXES

- A. Sheet Metal Outlet Boxes: NEMA OS 1, galvanized steel.
 - 1. Equipment Supporting Boxes: Rated for weight of equipment supported; include ½” male fixture studs where required.
- B. Nonmetallic Outlet Boxes: NEMA OS 2.
- C. Cast Boxes: NEMA FS, Type FD, cast fer alloy. Provide gasketed cover by box manufacturer. Provide threaded hubs.
- D. Wall Plates for Finished Areas: As specified in Section 260141.

2.2 PULL AND JUNCTION BOXES

- A. Sheet Metal Boxes: NEMA OS 1, galvanized steel.
- B. Surface Mounted Cast Metal Box: NEMA 250, Type 4 or 6; flatflanged, surface mounted junction box:
 - 1. Material: Galvanized cast iron or cast aluminum.
 - 2. Cover: Furnish with ground flange, neoprene gasket, and stainless-steel cover screws.

PART 3 - EXECUTION

3.1 EXAMINATION

- A. Verify locations of floor boxes and outlets prior to roughin.

3.2 INSTALLATION

- A. Install boxes in accordance with NECA "Standard of Installation."
- B. Install in locations as shown on Drawings, and as required for splices, taps, wire pulling, equipment connections and compliance with regulatory requirements.
- C. Set wall mounted boxes at elevations to accommodate mounting heights as indicated or as specified in section for outlet device.
- D. Electrical boxes are shown on Drawings in approximate locations unless dimensioned. Adjust box location up to 10 feet if required to accommodate intended purpose.
- E. Orient boxes to accommodate wiring devices oriented as specified in Section 260141.
- F. Maintain headroom and present neat mechanical appearance.
- G. Install pull boxes and junction boxes above accessible ceilings and in unfinished areas only.
- H. Inaccessible Ceiling Areas: Install outlet and junction boxes no more than 6 inches from ceiling access panel or from removable recessed luminaire.
- I. Install boxes to preserve fire resistance rating of partitions and other elements, using specified materials and methods.
- J. Coordinate mounting heights and locations of outlets mounted above counters, benches, and backsplashes.
- K. Align adjacent wall mounted outlet boxes for switches, thermostats, and similar devices.
- L. Use flush mounting outlet box in finished areas.
- M. Do not install flush mounting box back-to-back in walls; provide minimum 24 inches separation.
- N. Secure flush mounting box to interior wall and partition studs. Accurately position to allow for surface finish thickness.
- O. Install flush mounting box without damaging wall insulation or reducing its effectiveness.
- P. Do not fasten boxes to ceiling support wires.
- Q. Support boxes independently of conduit.

- R. Use cast boxes in exterior and wet locations such as bathrooms.
- S. Large Pull Boxes: Use hinged enclosure in interior dry locations, surface mounted cast metal box in other locations.

3.3 INTERFACE WITH OTHER PRODUCTS

- A. Coordinate installation of outlet box for equipment with corresponding trade.

3.4 ADJUSTING

- A. Adjust flush-mounted outlets to make front flush with finished wall material.
- B. Install knockout closures in unused box openings.

3.5 CLEANING

- A. Clean interior of boxes to remove dust, debris, and other material.
- B. Clean exposed surfaces and restore finish.

3.6 PAINTING

- A. Prime and paint raceway to match adjacent finishes in finished areas.

END OF SECTION 26 01 30

PART 1 - GENERAL

1.1 SECTION INCLUDES

- A. Grounding electrodes and conductors.
- B. Equipment grounding conductors.
- C. Bonding.

1.2 RELATED SECTIONS

- A. Drawings and general provisions of the Contract, including General and Supplementary Conditions, Division 1 Specifications and other Division 260 Specification Section, apply to this Section.

1.3 SCOPE

- A. Verify and bring existing conditions into compliance with the grounding and bonding specified in this section.

1.4 REFERENCES

- A. ANSI/NFPA 70 National Electrical Code.

1.5 GROUNDING ELECTRODE SYSTEM

- A. Metal underground water pipe.
- B. Metal frame of the building.
- C. Rod electrode.

1.6 PERFORMANCE REQUIREMENTS

- A. Grounding System Resistance: 25 ohms.

1.7 SUBMITTALS

- A. Submit under provisions of Section 260010.
- B. Product Data: Provide data for grounding electrodes and connections.
- C. Test Reports: Indicate overall resistance to ground and resistance of each electrode.
- D. Manufacturer's Instructions: Include instructions for storage, handling, protection, examination, preparation and installation of exothermic connectors.

1.8 QUALIFICATIONS

- A. Manufacturer: Company specializing in manufacturing Products specified in this Section with minimum three years documented experience.

1.9 REGULATORY REQUIREMENTS

- A. Conform to requirements of ANSI/NFPA 70.
- B. Furnish products listed and classified by third party agencies accredited by the NCBCC to label electrical and mechanical equipment, as suitable for purpose specified and shown, where such listing exists.

PART 2 - PRODUCTS

2.1 ROD ELECTRODE

- A. Material: Copper clad steel.
- B. Diameter: 3/4 inch.
- C. Length: 10 feet.

2.2 MECHANICAL CONNECTORS

- A. Material: Bronze.

2.3 WIRE

- A. Material: Stranded copper.
- B. Grounding Electrode Conductor: Size to meet NFPA 70 requirements.

PART 3 - EXECUTION

3.1 EXAMINATION

- A. Verify that final backfill and compaction has been completed before driving rod electrodes.

3.2 INSTALLATION

- A. Install Products in accordance with manufacturer's instructions.
- B. Install rod electrodes at locations indicated. Install additional rod electrodes as required to achieve specified resistance to ground.
- C. Provide bonding to meet Regulatory Requirements.
- D. Equipment Grounding Conductor: Provide a separate, green insulated conductor within each raceway, sized per NEC Table 250-122. Terminate each end on suitable lug, bus, or bushing.
- E. Where conduits are terminated in concentric, eccentric or oversize knockouts, terminate conduit with a bonding bushing and a green or bare grounding jumper, sized per NEC Table 250.102(C)(1)95, to the ground bar.
 - 1. All ground connections shall be accessible.

3.4 FIELD QUALITY CONTROL

- A. Inspect grounding and bonding system conductors and connections for tightness and proper installation.
- B. Use suitable test instrument to measure resistance to ground of system. Perform testing in accordance with Section 260123 Building Wire and Cable.

PART 1 - GENERAL

1.1 SECTION INCLUDES

- A. Conduit and equipment support.
- B. Anchors and fasteners.

1.1 RELATED SECTIONS

- A. Drawings and general provisions of the Contract, including General and Supplementary Conditions, Division 1 Specifications and other Division 26 Specification Section, apply to this Section.

1.2 REFERENCES

- A. NECA National Electrical Contractors Association.
- B. ANSI/NFPA 70 National Electrical Code.

1.4 SUBMITTALS

- A. Submit under provisions of Section 260010.
- B. Product Data: Provide manufacturer's catalog data for fastening systems.
- C. Manufacturer's Instructions: Indicate application conditions and limitations of use stipulated by Product testing agency specified under Regulatory Requirements. Include instructions for storage, handling, protection, examination, preparation, installation and starting of Product.

1.3 REGULATORY REQUIREMENTS

- A. Conform to requirements of ANSI/NFPA 70.
- B. Furnish products listed and classified by third party agencies accredited by the NCBC to label electrical and mechanical equipment, as suitable for purpose specified and shown, where such listing exists.

PART 2 - PRODUCTS

2.1 PRODUCT REQUIREMENTS

- A. Materials and Finishes: Provide adequate corrosion resistance.
- B. Provide materials, sizes, and types of anchors, fasteners and supports to carry the loads of equipment and conduit. Consider weight of wire in conduit when selecting products.
- C. Anchors and Fasteners:
 - 1. Toggle bolts on hollow masonry.
 - 2. Metal expansion shields and machine screws, or standard pre-set inserts on concrete or solid masonry.
 - 3. Machine screws or bolts on metal surfaces.
 - 4. Wood screws on wood construction.

2.1 CHANNEL AND SUPPORT SYSTEMS

- A. Channel and angle support systems, hangers, anchors, sleeves, brackets, fabricated items and fasteners, shall be designed to provide secure support from the building structure, for electrical components.
- B. Description:
 - 1. Steel, unless otherwise noted shall be protected from corrosion with zinc coating, or with a treatment of equivalent corrosion resistance, using approved alternative finish or inherent material characteristics.
 - 2. Metal items for outdoor or damp location use shall be hot-dip galvanized steel, unless otherwise noted.
 - 3. Steel channel shall have 9/16-inch diameter holes at a maximum of 8 inches on center, in at least one surface.
 - 4. Fittings and accessories for steel channel shall match and mate and be from the same manufacturer.

PART 3 - EXECUTION

3.1 INSTALLATION

- A. Install products in accordance with manufacturer's instructions in unfinished spaces only.
- B. Conceal supports in finished spaces.
- C. Provide anchors, fasteners, and supports in accordance with NECA "Standard of Installation".
- D. Do not fasten supports to pipes, ducts, mechanical equipment, and conduit.
- E. Obtain permission from Engineer before using powder actuated anchors.
- F. Do not drill or cut structural members.
- G. Fabricate supports from structural steel or steel channel. Rigidly weld members or use hexagon head bolts to present neat appearance with adequate strength and rigidity. Use spring lock washers under all nuts.
- H. Install surface mounted cabinets and panelboards with minimum of four anchors.
- I. In wet and damp locations use steel channel supports to stand cabinets and panelboards one inch off wall.
- J. Use sheet metal channel to bridge studs above and below cabinets and panelboards recessed in hollow partitions.
- K. Conduits installed on the interior side of exterior walls shall be spaced a minimum of 1/4" off the walls.
- L. Conduit hangers shall not be used below 8' on walls to avoid snagging of clothing articles and other injuries. Use conduit straps and bent offsets as needed for exposed terminations.

END OF SECTION 26 01 90

PART 1 - GENERAL

1.1 SECTION INCLUDES

- A. Nameplates and labels.
- B. Wire and cable markers.
- C. Conduit markers.

1.2 RELATED SECTIONS

- A. Drawings and general provisions of the Contract, including General and Supplementary Conditions, Division 1 Specifications and other Division 260 Specification Section, apply to this Section.

1.3 REFERENCES

- A. ANSI/NFPA 70 National Electrical Code.

1.4 SUBMITTALS

- A. Submit under provisions of Section 260010.
- B. Product Data: Provide catalog data for nameplates, labels, and markers.
- C. Manufacturer's Instructions: Indicate application conditions and limitations of use stipulated by Product testing agency specified under regulatory requirements. Include instructions for storage, handling, protection, examination, preparation, and installation of Product.

1.5 REGULATORY REQUIREMENTS

- A. Conform to requirements of ANSI/NFPA 70.
- B. Furnish products listed and classified by third party agencies accredited by the NCBC to label electrical and mechanical equipment, as suitable for purpose specified and shown, where such listing exists.

PART 2 - PRODUCTS

2.1 NAMEPLATES AND LABELS

- A. Nameplates: Furnish and install engraved laminated phenolic nameplates for all safety switches, panelboards, transformers, switchboards, motor control centers and other electrical equipment supplied for the project for identification of equipment, controlled, served, phase, voltage, etc. Nameplates shall be securely attached to equipment with pop-rivets of suitable material and size, and shall identify equipment controlled, attached, etc. Letters shall be 1/2-inch-high minimum. Embossed and printed self-adhesive plastic tape is not acceptable for marking equipment. Nameplate material colors shall be:

- 1. 208 Volt System: Blue surface with white core

- B. Locations:

1. Each safety switch, panelboard, transformer, switchboard, main feeder circuit breakers and other electrical equipment supplied for the project. Information on the nameplate shall include equipment controlled and/or served, phase and voltage.

C. Letter Size: Minimum of 1/2 inch.

D. Labels: Printed adhesive tape, with 3/8-inch black letters on transparent background. Use only for identification of individual wall switches and receptacles with their corresponding electrical panel and breaker numbers.

E. Label Information: Equipment controlled and/or served - voltage, phase, etc.

2.2 WIRE MARKERS

A. Description: Cloth, tape, split sleeve, or tubing type wire markers.

B. Locations: Each conductor at panelboard gutters, pull boxes, outlet and junction boxes and each load connection.

C. Legend:

1. Power and Lighting Circuits: Branch circuit or feeder number indicated on drawings.

2.3 CONDUIT MARKERS

A. Location: Furnish markers for each conduit longer than 20 feet.

B. Color:

1. Fire Alarm System: Bright Red.
2. 208 Volt System: Blue.

C. As an alternative to the above requirements, conduit in unfinished areas may be marked with spray paint.

D. Empty conduit runs and conduit with conductors for future use shall be identified for use and shall indicate where they terminate. Identification shall be by tags with string or wire attached to conduit or outlet.

2.4 UNDERGROUND WARNING TAPE

A. Description: 6-inch-wide, 4 mils thick, plastic tape, detectable type, bright colored with suitable warning legend, continuously printed, describing buried electrical lines.

PART 3 - EXECUTION

3.1 PREPARATION

A. Degrease and clean surfaces to receive nameplates and labels.

3.2 APPLICATION

A. Install nameplates and labels parallel to equipment lines.

B. Secure nameplate to equipment front using self-tapping stainless-steel screws.

C. Paint colored band on each conduit longer than 20 feet, 20 feet on center.

- D. Junction and pull boxes in conduit runs shall have their covers and exterior surfaces painted to match the colors in 2.3B above. This includes covers on boxes above lift-out and other type accessible ceilings.
- E. Identify all underground conduits using underground warning tape. Install one tape per trench at 6 to 8 inches below finished grade.
- F. Empty conduits and conduits with conductors, for future use shall be identified for use and shall indicate on each end where they terminate. Identification shall be by tags with string or wire attached to the conduit or outlet.

END OF SECTION 26 01 95

ENCLOSED SWITCHES & ENCLOSED CIRCUIT BREAKERS**PART 1 - GENERAL**

1.1 SECTION INCLUDES

- A. Fusible switches.
- B. Non-fusible switches.
- C. Fuses.
- D. Enclosed Circuit Breakers.

1.2 RELATED SECTIONS

- A. Drawings and general provisions of the Contract, including General and Supplementary Conditions, Division 1 Specifications and other Division 260 Specification Section, apply to this Section.
- B. Section 26 08 00 - Commissioning of Electrical

1.3 REFERENCES

- A. NEMA KS 1 Enclosed Switches.
- B. NFPA 70 National Electrical Code.
- C. UL 198C High Interrupting Capacity Fuses; Current Limiting Type.
- D. UL 198E Class R Fuses.

1.4 SUBMITTALS

- A. Submit under provisions of Section 260010.
- B. Product Data: Provide switch ratings and enclosure dimensions.
- C. Manufacturer's Instructions: Indicate application conditions and limitations of use stipulated by Product testing agency specified under Regulatory Requirements. Include instructions for storage, handling, protection, examination, preparation, installation, and starting of Product.

1.5 QUALITY ASSURANCE

- A. Perform Work in accordance with NECA Standard of Installation.
- B. Maintain one copy of each document on site.

1.6 QUALIFICATIONS

- A. Manufacturer: Company specializing in manufacturing Products specified in this Section with minimum three years documented experience.

1.7 REGULATORY REQUIREMENTS

- A. Conform to requirements of NFPA 70.

- B. Furnish products listed and classified by third party agencies accredited by the NCBCB to label electrical and mechanical equipment, as suitable for purpose specified and shown, where such listing exists.

PART 2 - PRODUCTS

2.1 MANUFACTURERS

- A. Square D.
- B. Eaton.
- C. General Electric.
- D. Siemens/ITE
- E. Substitutions: Under provisions of Section 260010.

2.2 ENCLOSED SWITCHES

- A. Fusible Switch Assemblies: NEMA KS 1, Type HD (Heavy Duty) load interrupter enclosed knife switch with externally operable handle interlocked (with defeat mechanism) to prevent opening front cover with switch in ON position. Handle lockable in ON or OFF position. Fuse clips: Designed to accommodate Class R fuses.
- B. Nonfusible Switch Assemblies: NEMA KS 1, Type HD (Heavy Duty) load interrupter enclosed knife switch with externally operable handle interlocked (with defeat mechanism) to prevent opening front cover with switch in ON position. Handle lockable in ON or OFF position.
- C. Provide service entrance rated fused disconnect switches and two grounding electrodes where they connect directly to utility transformers.
- D. Enclosures: NEMA KS 1.
 - 1. Interior Dry Locations in Production Areas: NEMA 250 Type 12.
 - 2. Interior Dry Locations in Non-Production Areas: NEMA 250 Type 1.
 - 3. Exterior, Wet and Damp Locations: NEMA 250 Type 3R.
- E. Switches shall have handles whose positions are easily recognizable in the “on” or “off” position. For safety reasons, padlock shall be provided for switches located in the public areas.
- F. Switches shall have nontearable, positive, quick make-quick break mechanisms.
- G. General duty switches are not acceptable.

2.3 ENCLOSED CIRCUIT BREAKERS

- A. Molded-Case Circuit Breaker: NEMA AB 1, with interrupting capacity to meet available fault currents.
 - 1. Thermal-Magnetic Circuit Breakers: Inverse time-current element for low-level overloads, and instantaneous magnetic trip element for short circuits. Adjustable magnetic trip setting for circuit-breaker frame sizes 250 A and larger.
 - 2. Adjustable Instantaneous-Trip Circuit Breakers: Magnetic trip element with front-mounted, field-adjustable trip setting.
 - 3. Current-Limiting Circuit Breakers: Frame sizes 400 A and smaller; let-through ratings less than NEMA FU 1, RK-5.
 - 4. GFCI Circuit Breakers: Single- and two-pole configurations with 5-mA trip sensitivity.

- B. Molded-Case Circuit-Breaker Features and Accessories: Standard frame sizes, trip ratings, and number of poles.
 - 1. Lugs: Suitable for number, size, trip ratings, and material of conductors.
 - 2. Application Listing: Appropriate for application; Type SWD for switching fluorescent lighting loads; Type HACR for heating, air-conditioning, and refrigerating equipment.
 - 3. Ground-Fault Protection: Integrally mounted relay and trip unit with adjustable pickup and time-delay settings, push-to-test feature, and ground-fault indicator.
 - 4. Shunt Trip: 120-V trip coil energized from separate circuit, set to trip at 75 percent of rated voltage.

2.4 ENCLOSURES

- A. NEMA KS 1 enclosures listed for environmental conditions of installed locations, including:
 - 1. Interior Dry Locations in Production Areas: NEMA 250 Type 12.
 - 2. Interior Dry Locations in Non-Production Areas: NEMA 250 Type 1.
 - 3. Exterior, Wet and Damp Locations: NEMA 250 Type 3R.
 - 4. Other Wet or Damp Indoor Locations: NEMA 250, Type 4.

2.5 FUSES

- A. Manufacturers:
 - 1. Bussmann
 - 2. Reliance
 - 3. Substitutions: Under provisions of Section 260010.
- B. Description: Dual element, current limiting, time delay, voltage as indicated on the Drawings, UL 198E, Class RK 5 unless noted otherwise on the Drawings.
- C. Interrupting Rating: 200,000 RMS amperes.

PART 3 - EXECUTION

3.1 INSTALLATION

- A. Install disconnect switches where indicated.
- B. Install fuses in fusible disconnect switches.
- C. Label switches per Section 26 01 95 Electrical Identification.
- D. Provide adhesive label on inside door of each switch indicating UL fuse class and size for replacement.

END OF SECTION 26 04 41

BID EVALUATION FORM



Project: Centruy Center Chiller Replacement and DDC Controls Upgrade
Institute: Town of Carrboro
OWNER Project ID:
Date: April 17, 2024
Time: 3:00 P.M.

Contractors (Prime)	Comfort Systems USA (MidAtlantic), LLC	Environmental Air Systems DBA Envirotrol	Superior Mechanical Services, Inc
Contractor License	45477	23060	18629
Addendum Received 1, 2, & 3	✓	✓	✓
Bid Bond	✓	✓	✓
MBE	✓	✓	✓
BASE BID	\$464,326.00	\$409,000.00	\$492,000.00
Sub-Contractors			
Plumbing	Comfort Systems USA (MidAtlantic), LLC		
Contractor License	35609		
Mechanical	Comfort Systems USA (MidAtlantic), LLC		Superior Mechanical Services, Inc
Contractor License	35609		18629
Electrical	Comfort Systems USA (MidAtlantic), LLC	Schoolfield Electric	Champion Wuthrich Electric
Contractor License	31285-U	U.20993	U10589
OWNER PREFERRED ALTERNATES			
Owner Preferred Alternate No. OP-M1: Provide DDC controls by Honeywell Building Technologies, subject to compliance with the requirements of the specifications.	Add/Deduct	Add/Deduct	Add/Deduct
	\$0.00	\$0.00	\$0.00
ALLOWANCES			
Allowance No. 1: CONTINGENCY ALLOWANCE Allowance for replacing existing devices found to be faulty	Base Bid = \$30,000	Base Bid = \$30,000	Base Bid = \$30,000
UNIT PRICES			
MECHANICAL			
A. Provide price for replacing a faulty water control valve (1/2" through 1")	Per valve	Per valve	Per valve
	\$210.00	\$121.00	\$875.00
B. Provide price for replacing a faulty water control valve (1-1/4" through 2")	Per valve	Per valve	Per valve
	\$267.00	\$787.00	\$1,195.00
C. Provide price for replacing a faulty control damper	Per sq. ft. of damper	Per sq. ft. of damper	Per sq. ft. of damper
	\$590.00	\$170.00	\$735.00
D. Provide price for replacing a faulty valve actuator for 1/2" through 1"	Per valve actuator	Per valve actuator	Per valve actuator
	\$340.00	\$240.00	\$875.00
E. Provide price for replacing a faulty valve actuator for 1-1/4" through 2"	Per valve actuator	Per valve actuator	Per valve actuator
	\$375.00	\$435.00	\$995.00
F. Provide price for replacing a faulty damper actuator	Per damper actuator	Per damper actuator	Per damper actuator
	\$480.00	\$398.00	\$885.00

I (WE) hereby certify that this is a true and accurate tabulation of bids received this day.

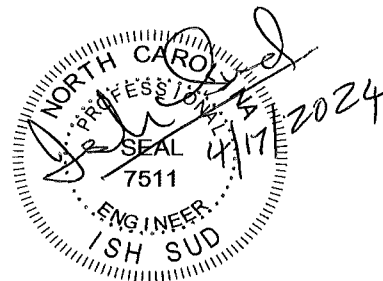

**A RESOLUTION FOR AWARDING THE CONTRACT
FOR REPLACEMENT OF THE CENTURY CENTER CHILLER
AND DIRECT DIGITAL CONTROL SYSTEM UPGRADES**

WHEREAS the Town of Carrboro's Energy and Climate Protection Plan and Carrboro's Comprehensive Plan outlines a goal of reducing the Town's 2010 emissions 80% by 2030; and,

WHEREAS the Town worked with a consultant to establish a baseline of the building energy use and develop a rating system to prioritize buildings for efficiency projects; and,

WHEREAS the Town's Comprehensive Plan prioritizes Town Hall and the Century Center for energy efficiency projects (Strategy 1.2A); and,

WHEREAS, the Century Center chiller is aging, inefficient, and in need of replacement and the DDC system is obsolete and Town staff is unable to program it for effective control and energy conservation; and,

WHEREAS the Town received three (3) responses to the Request for Proposals for replacement of the Century Center chiller and Direct Digital Control (DDC) system upgrades; and,

WHEREAS, Sud Associates, PA and Town staff have identified Environmental Air Systems DBA Envirotrol as the lowest bidder; and,

WHEREAS, funding has been allocated for the replacement of the Century Center chiller and DDC system upgrades in the Facilities Rehabilitation Fund; and,

NOW THEREFORE, BE IT RESOLVED that the Carrboro Town Council authorizes the Town Manager to award a contract to Environmental Air Systems DBA Envirotrol for the replacement of the Century Center chiller and DDC system upgrades, in the amount not to exceed \$409,000.

This the 7th day of May in 2024.

Race and Equity Pocket Questions

Title and purpose of this initiative: Century Center Chiller Replacement and Direct Digital Control (DCC) system upgrades.

Department: Public Works

What are the racial and equity impacts?

The Century Center chiller (cooling system) is aging, inefficient, and in need of replacement and the DDC system is obsolete as Town staff are unable to program it for effective control and energy conservation. For example, the lack of proper control is resulting in a significant amount of excess reheat during the summer and employees have observed that the existing chiller is unable to meet the building's cooling requirements.

Historically, marginalized communities suffer and will suffer disproportionately larger impacts due to climate disruption. The cooling system in the Century Center represents 11.3% of the buildings energy consumption. Replacement of the chiller and DDC system upgrades have the potential to reduce the Town's municipal greenhouse gas emissions, showing a commitment to reducing burdens that historically disadvantaged groups face because of greenhouse gas emissions.

There is also a racial disparity in households who experience severe cost burden in the community: 15% of white, non-Hispanic households in Carrboro experience severe cost burden, while 19% of Hispanic households and 21% of Black households experience severe cost burden. Replacement of the chiller and DDC system upgrades have the potential to reduce the Town's maintenance and utility expenses, again showing a commitment to reducing burdens that historically disadvantaged groups face because of greenhouse gas emissions.

Any reduction in the Town's use of fossil fuels will have an impact on air quality, which has a disproportionate impact on the health of marginalized communities, especially children. Additionally, reduction in the Town's maintenance and utility expenses may benefit households who experience severe cost burden in the Town.

Who is or will experience community burden?

Replacement of the Century Center chiller and DDC upgrades may burden:

- Taxpayers due to the expense of the repair.
- Community members who may face barriers in accessing the Century Center such as, but not limited to, individuals who may be required to work during the facility's accessible

hours, those with health conditions hindering participation or individuals impacted by other circumstances.

- Pedestrians near the Century Center during installation may be burdened due to the closure of sidewalks during construction.
- Noise and dust during construction may burden community members and businesses near the Century Center.
- Town staff and visitors may be burdened due to the lack of air-conditioning in the building while the new chiller is being installed and DDC system upgraded. Although the new chiller will be installed during winter months, unseasonably warm temperatures may impact individuals in the building.
- Companies that were not awarded the contract will not be receiving business from the Town. Staff ensured that all Town procurement procedures were followed throughout the process.
- Contractors and Town staff due to time involved.

Who is or will experience community benefit?

Replacement of the Century Center chiller and DDC upgrades may benefit:

- Community members, visitors, and Town staff due to the reduction in GHG emissions, improvements in air quality, the ability to maintain indoor temperatures and thermal comfort, and the reduction in time and expense associated with the use and maintenance of the existing chiller.
- Environmental Air Systems DBA Envirotrol company, sub-contractors, and their employees will benefit from being awarded the contract to replace the Century Center chiller and upgrade the DDC system.

What are the root causes of inequity?

Institutional policies, both intentional and unintentional, have created inequities for Black and other marginalized communities (for example, people with disabilities and refugee populations) in employment, housing, generational wealth, and health outcomes, and can include shorter lifespan and higher susceptibility to cardiovascular and pulmonary disease caused by exposure to airborne particulates. These inequities will only be exacerbated by continued business-as-usual fossil fuel use and its associated greenhouse gas emissions and climate disruption.

What might be the unintended consequences of this action or strategy?

Unintended consequences include:

- Opportunity costs from using Town funds to replace the Century Center chiller and upgrade the DDC system may prevent the funding of other programs that would directly benefit Black and other historically marginalized and low-income communities or those with disabilities.
- Some community members may have a negative perception of the building improvement.
- Community members and businesses located near the Century Center may be burdened with noise, dust, or the closure of sidewalks during construction.

How is your department planning to mitigate any burdens, inequities, and unintended consequences?

The Town will monitor feedback from patrons and daily use patterns to identify any currently unforeseen burdens or inequities and address those with corrective measures as needed.



Agenda Item Abstract

File Number: 24-094

Agenda Date: 5/7/2024
In Control: Town Council
Version: 1

File Type: Consent Agenda

Request to Set Legislative Public Hearing for Text Amendments

PURPOSE: To request the Town Council consider setting a public hearing on revised text amendments to the Land Use Ordinance relating to Cafes and Residential Density in Certain Zoning Districts. A resolution setting a public hearing for June 18, 2024, has been provided.

DEPARTMENT: Planning

CONTACT INFORMATION: Christina Moon, Planning & Transportation Administrator, 919-918-7325, cmoon@carrboronc.gov; Patricia McGuire, Planning Director, 919-918-7327, pmcguire@carrboronc.gov

COUNCIL DIRECTION:

Race/Equity Climate Comprehensive Plan Other

Setting a public hearing for a text amendment to the Land Use Ordinance is a required step in accordance with North Carolina state statutes and Town regulations. Responses to the racial equity pocket questions related to the legislative public hearing process necessary for the consideration of the text amendment have been prepared and are attached.

INFORMATION: On April 23, 2024, the Town Council held a public hearing on proposed text amendments to the Land Use Ordinance relating to cafes and residential density in certain zoning districts ([Town of Carrboro - Meeting of Town Council on 4/23/2024 at 7:00 PM \(legistar.com\)](#) <<https://carrboro.legistar.com/MeetingDetail.aspx?ID=1155307&GUID=48B64113-2FF1-45A1-8C0A-53A7FEA807C0&Options=info&Search=>>>). The request was submitted by Heather Washburn of Calico Studio to support a pending major modification to an existing special use permit-A for a live-work project at 603 Jones Ferry Road. The draft ordinance contained two parts. The first part established a new land use for neighborhood cafes, with associated permit requirements, parking standards, etc. The second part provided for an increase in the residential density in the Office (O) and Office/Assembly (O/A) zoning districts subject to certain criteria.

During deliberations Town Council members directed staff to revise the draft ordinance in the following ways:

- increase the gross floor area necessitating a special use permit for neighborhood cafes from 1,000 sf to 1,500 sf.
- remove the presumptive parking standards for neighborhood cafes,
- increase the potential residential density for the O and O/A districts from 3,000 per dwelling unit to 2,000 per dwelling unit, and
- remove two of three criteria for allowing the increased density for the O and O/A districts.

A revised draft ordinance is provided (*Attachment B*). The Town Council must receive public comment before taking action on the draft ordinance. Orange County and Planning Board review is also needed, and the Town

Council may wish to refer the item to advisory boards based on their expertise; staff has identified the Appearance Commission, Transportation Advisory Board, Environmental Advisory Board, Economic Sustainability Commission and Affordable Housing Advisory Commission.

FISCAL IMPACT: There is no fiscal impact relating to setting a public hearing. Costs and staff time are associated with public hearing and advisory board review. The applicant has submitted the fee associated with the text amendment request.

RECOMMENDATION: Staff recommends that the Town Council consider the resolution (*Attachment A*) setting a public hearing for June 18, 2024, and referring the item to Orange County, the Planning Board, and other advisory boards based on their area of expertise.

A RESOLUTION SETTING A PUBLIC HEARING ON A REVISED ORDINANCE
AMENDING THE CARRBORO LAND USE ORDINANCE RELATING TO RESIDENTIAL
DENSITY AND RESTAURANT USES

WHEREAS the Carrboro Town Council seeks to provide ample opportunities for the public to comment on proposed amendments to the Land Use Ordinance.

NOW, THEREFORE BE IT RESOLVED that the Town Council sets a public hearing on June 18, 2024, to consider adopting “A revised Ordinance Amending the Carrboro Land Use Ordinance Relating to Residential Density and Restaurant Uses.”

BE IT FURTHER RESOLVED that the revised draft ordinance is referred to Orange County and the Town of Carrboro Planning Board for consideration and recommendation prior to the specified public hearing date.

BE IT FURTHER RESOLVED that the revised draft ordinance is also referred to the following Town of Carrboro advisory boards and commissions.

- | | |
|--|--|
| <input checked="" type="checkbox"/> Appearance Commission | <input type="checkbox"/> Recreation and Parks Commission |
| <input checked="" type="checkbox"/> Transportation Advisory Board | <input type="checkbox"/> Northern Transition Area Advisory Committee |
| <input checked="" type="checkbox"/> Environmental Advisory Board | <input checked="" type="checkbox"/> Affordable Housing Advisory Commission |
| <input checked="" type="checkbox"/> Economic Sustainability Commission | <input type="checkbox"/> _____ |

This is the 7th day of May in the year 2024.

AN ORDINANCE AMENDING THE CARRBORO LAND USE ORDINANCE RELATING TO CAFES AND RESIDENTIAL DENSITY IN CERTAIN ZONING DISTRICTS.

DRAFT 4-26-2024

THE TOWN COUNCIL OF THE TOWN OF CARRBORO ORDAINS:

Section 1. Article II, Section 15-15 Definition of Basic Terms of the Carrboro Land Use Ordinance is amended by the addition of a new definition, in appropriate alphabetical order, that reads as follows:

NEIGHBORHOOD CAFÉ. A retail business that sells principally coffee and tea along with baked goods and similar foods prepared off site.

Section 2. Article X, Section 15-146 Table of Permissible Uses is by adding a new use classification, 8.900, Neighborhood Cafe, and by adding a “ZA(l)” under the columns for the B-1C, B-1G, HR-CC, O, and O/A districts, and an “A” under the columns for the B-2, B-3, B-3T, B-5, and HR-R districts.

Alternate Section 2. Article X, Section 15-146 Table of Permissible Uses is by adding a new use classification, 8.900, Neighborhood Cafe, and by adding a “ZA(l)” under the columns for the O and O/A districts.

Section 3. Article X, Section 15-147 Use of the Designations A, B, Z in Table of Permissible Uses is amended by rewriting subsection (i) to read as follows:

(i) When used in connection with 8.100, 8.200, 8.500 and 8.600 uses, the designation “ZA(l)” means that a zoning permit must be obtained if the total area within a development to be used for this purpose does not exceed 1,500 square feet and the use is to take place in a building in existence on the effective date of this subsection while a special use permit-A must be obtained whenever the total area to be used for this purpose is equal to or exceeds 1,500 square feet.

When used in conjunction with 8.900 uses, the designation “ZA(l)” means that a zoning permit must be obtained if the total area within a development to be used for this purpose does not exceed 1,500 square feet of gross floor area and a special use permit-A must be obtained whenever the total area to be used for this purpose exceeds 1,500 square feet of gross floor area or the use is proposed within a new building.

Section 4. Article XII, Sub-section 15-182 Residential Density is amended with the addition of a new subsection (j) that reads as follows:

(j) Notwithstanding the foregoing, the minimum square feet per dwelling unit required shall be 2,000 square feet within the O and O/A districts so long as such units are included within a vertically integrated, multi-family residential and mixed-use development that includes at least 15 percent affordable housing units that meet the affordable criteria specified in Sections 15-54.1 and 15-182.4

Section 5. Article XVIII, Section 15-291(g) is amended by adding use category 8.900 “Neighborhood Cafe” to Part I of the Table of Parking Requirements and assigning a parking requirement of 0 spaces.

Section 6. Article XVIII, Section 15-291(h) is amended by adding use category 8.900 “Neighborhood Cafe” to the Table of Bicycle Parking Standards assigning a minimum of 5 spaces.

Section 7. All provisions any town ordinance in conflict with this ordinance are repealed.

Section 8. This ordinance shall become effective upon adoption.

AN ORDINANCE AMENDING THE CARRBORO LAND USE ORDINANCE RELATING TO CAFES AND RESIDENTIAL DENSITY IN CERTAIN ZONING DISTRICTS.

DRAFT 4-26-2024

THE TOWN COUNCIL OF THE TOWN OF CARRBORO ORDAINS:

Section 1. Article II, Section 15-15 Definition of Basic Terms of the Carrboro Land Use Ordinance is amended by the addition of a new definition, in appropriate alphabetical order, that reads as follows:

NEIGHBORHOOD CAFÉ. A retail business that sells principally coffee and tea along with baked goods and similar foods prepared off site.

Section 2. Article X, Section 15-146 Table of Permissible Uses is by adding a new use classification, 8.900, Neighborhood Cafe, and by adding a “ZA(l)” under the columns for the B-1C, B-1G, HR-CC, O, and O/A districts, and an “A” under the columns for the B-2, B-3, B-3T, B-5, and HR-R districts.

Alternate Section 2. Article X, Section 15-146 Table of Permissible Uses is by adding a new use classification, 8.900, Neighborhood Cafe, and by adding a “ZA(l)” under the columns for the O and O/A districts.

Section 3. Article X, Section 15-147 Use of the Designations A, B, Z in Table of Permissible Uses is amended by rewriting subsection (i) to read as follows:

(i) When used in connection with 8.100, 8.200, 8.500 and 8.600 uses, the designation “ZA(l)” means that a zoning permit must be obtained if the total area within a development to be used for this purpose does not exceed 1,500 square feet and the use is to take place in a building in existence on the effective date of this subsection while a special use permit-A must be obtained whenever the total area to be used for this purpose is equal to or exceeds 1,500 square feet.

When used in conjunction with 8.900 uses, the designation “ZA(l)” means that a zoning permit must be obtained if the total area within a development to be used for this purpose does not exceed 1,500 square feet of gross floor area and a special use permit-A must be obtained whenever the total area to be used for this purpose exceeds 1,500 square feet of gross floor area or the use is proposed within a new building.

Section 4. Article XII, Sub-section 15-182 Residential Density is amended with the addition of a new subsection (j) that reads as follows:

(j) Notwithstanding the foregoing, the minimum square feet per dwelling unit required shall be 2,000 square feet within the O and O/A districts so long as such units are included within a vertically integrated, multi-family residential and mixed-use development that includes at least 15 percent affordable housing units that meet the affordable criteria specified in Sections 15-54.1 and 15-182.4

Section 5. Article XVIII, Section 15-291(g) is amended by adding use category 8.900 “Neighborhood Cafe” to Part I of the Table of Parking Requirements and assigning a parking requirement of 0 spaces.

Section 6. Article XVIII, Section 15-291(h) is amended by adding use category 8.900 “Neighborhood Cafe” to the Table of Bicycle Parking Standards assigning a minimum of 5 spaces.

Section 7. All provisions any town ordinance in conflict with this ordinance are repealed.

Section 8. This ordinance shall become effective upon adoption.

APPENDIX A – 3

LAND USE ORDINANCE AMENDMENT REQUEST FORM

TOWN OF CARRBORO

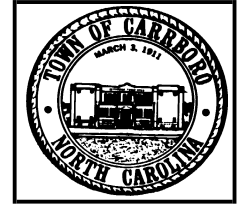

LAND USE ORDINANCE AMENDMENT REQUEST

"Dear Potential Business Operator:

Please be advised that it may be necessary to meet with several members of Town staff as well as outside agencies to identify and fully understand all rules, regulations, and policies applicable to your business."

To the Town Council, the Planning Board, and the Appearance Commission, as appropriate, of the Town of Carrboro:

I (we), the undersigned do hereby respectfully make application and petition the Carrboro Town Council to amend the Land Use Ordinance. In support of this application, the following facts are shown:

- 1) **The Land Use Ordinance, at present, would allow (description/quote, page and number of section in question):**
15-146 Table of Permissible Uses, Use Category 8.000, allows restaurants in some zoning districts...but not in the O (office) zoning district
- 2) **The proposed amendment to the Land Use Ordinance would allow (describe briefly intended change):**
Creation of a new Use Category 8.900: Neighborhood Coffee Shop with a maximum floor area of 1,000 sf, located within a vertically oriented mixed use building with a residential primary use, selling only beverages along with baked goods prepared off site.
The Use Table would be amended to allow this use as a "ZA" Use (Zoning Permit from Town Council) and in the following Districts: B-1C, B-1G, O and O/A. Also as an "A" (Allowed) use in HR-CC, B-2 and B-5, and also a "Z" (Admin. Zoning Permit) in the B-4 District.
- 3) **State the reasons for the proposed amendment:**
Small local gathering places such as coffee shops are a critical component of creating walkable "third place" destinations in residential areas, particularly when they can be combined in a vertical mixed use residential building. These would allow the ability to have social interaction, organic co-working, and a less car-dependent location.

SIGNATURE:

applicant

Heather Washburn
 {print}

ADDRESS:

1155 Smith Level Road
Chapel Hill, NC 27516

TELEPHONE NUMBER: 617.869.9646

TOWN OF CARRBORO



LAND USE ORDINANCE AMENDMENT REQUEST

“Dear Potential Business Operator:

Please be advised that it may be necessary to meet with several members of Town staff as well as outside agencies to identify and fully understand all rules, regulations, and policies applicable to your business.”

To the Town Council, the Planning Board, and the Appearance Commission, as appropriate, of the Town of Carrboro:

I (we), the undersigned do hereby respectfully make application and petition the Carrboro Town Council to amend the Land Use Ordinance. In support of this application, the following facts are shown:

- 1) **The Land Use Ordinance, at present, would allow (description/quote, page and number of section in question):**
15-182 (a) Residential Density - requires a minimum of 7,500 sf of land area per Dwelling Unit, for Multi-Family and Duplex uses in an O (Office) Zoning District.

- 2) **The proposed amendment to the Land Use Ordinance would allow (describe briefly intended change):** The intent would be to allow less land area per unit in specific zoning districts if the proposed project is vertically integrated, adjacent to a transit route, and uses the affordable housing density bonus. Suggested language:

Subject to the other provisions of this section and the provisions of Section 15-186 (Cluster Subdivisions), 15-187 (Architecturally Integrated Subdivisions), 15-182.1 (Density in R-SIR Zoning), **and 15-182 (j)**, every lot developed for residential purposes shall have the number of square feet per dwelling unit indicated in the following table. In determining the number of dwelling units permissible on a tract of land (by dividing the total number of square feet the tract contains by the minimum per dwelling unit), fractions shall be dropped.

Further, add subparagraph (j) to 15-182 with the following language:

(j) Within the zoning districts listed below, residential units that are incorporated into a vertical mixed use building with at least 500 sf of non-residential uses, adjacent to a transit corridor and commits to using the Affordable Housing Density Bonus, may be developed for multi-family residential purposes at a density such that such area contains at least the following number of square feet for each dwelling unit constructed thereon:

Zone	Minimum Square Feet per Dwelling Unit
B-2	3,000
B-3	3,000
B-3-T	3,000
CT	3,000
O	3,000
O/A	3,000

3) **State the reasons for the proposed amendment:**

Greater density in vertically integrated residential projects will encourage walkable communities, especially where affordable housing is provided and proximate to Public Transportation. This should be encouraged in in non-residential zones in order to achieve the Town’s goals of providing denser, affordable walkable communities in a manner which makes housing accessible to more residents.

SIGNATURE:  Heather Washburn
applicant {print}

ADDRESS: 1155 Smith Level Road
Chapel Hill, NC 27516

TELEPHONE NUMBER: 617.869.9646

Race and Equity Pocket Questions

Title and purpose of this initiative:

Request to Set Legislative Public Hearing Relating to Cafes and Residential Density in Certain Zoning Districts. The purpose of this agenda item is to request the Town Council consider setting a public hearing on revised text amendments to the Land Use Ordinance relating to residential density and restaurant uses.

Department: Planning

What are the racial and equity impacts?

Lack of representation on elected and appointed boards (advisory boards also provide comments for public hearings) can reduce participation, especially by those who do not learn about these types of processes and/or are unable to participate in meetings. Decisions might be made without considering these points of view.

Who is or will experience community burden?

Shift workers and people who have limited time, transportation choices and/or children may have difficulty finding the time to learn about a proposal, attending meetings, understanding how and when to provide input, and to whom. It takes time to learn the development process and to obtain a comfort level to participate. Language may also provide a barrier for some residents.

Who is or will experience community benefit?

The public hearing process requires that these types of legislative decisions occur in a public form and that the community can comment before a decision is made. Beneficiaries include those who are able/available to and do participate in these ways and those who support or see no negative effects from the changes.

What are the root causes of inequity?

Structural racism in government decisions, particularly those relating to land use, as well as residents' personal experiences with government, can further alienate those that may find it difficult to attend meetings—like working individuals and families—and contribute to a reticence by historically marginalized people to speak in a public setting. Disparate access to quality education, which in turn affects economic outcomes, as well as historical barriers to government for community members of color can lead to undue burden.

What might be the unintended consequences of this action or strategy?

Changes to land use regulations can affect land values and quality of life experiences for surrounding property owners and occupants in ways that can be beneficial and, albeit for some, less desirable. The request for this particular text amendment would, if approved, allow for additional residential density in the Office Zoning District and restaurant uses that do not require a commercial kitchen, uses which may provide additional housing opportunities for some residents and additional business opportunities for local entrepreneurs.

The public hearing process is intended to provide a way for developers and community members to learn about a proposal and provide input in a public setting. Even with published notice and social media releases, some people may not learn of a proposed amendment to the Land Use Ordinance in time to provide input and/or feel that they understand the project and/or approval process enough to fully



TOWN OF CARRBORO • NC
FACING RACE, EMBRACING EQUITY

participate. The Planning Department has completed the analysis for a REAL lens for the amendment process. Once the final departmental review is complete, the staff core team and Racial Equity Commission will review and provide recommendations.

How is your department planning to mitigate any burdens, inequities, and unintended consequences?

Suggestions outlined in the REAL lens assessment involves options for better public engagement moving forward. Of note, this would involve efforts to go beyond what is required by state statute and the Land Use Ordinance



Agenda Item Abstract

File Number: 24-098

Agenda Date: 5/7/2024
In Control: Town Council
Version: 2

File Type: Consent Agenda

Town Council 2023-2024 Retreat Summary

PURPOSE: This item is to provide a summary of matters discussed during the Carrboro Town Council 2023-2024 retreat that took place February 3, 2024. Important topics of discussion include council priorities for the LUO rewrite, the FY24-25 budget, and council norms.

DEPARTMENT: Town Managers Office

CONTACT INFORMATION: Marie Parker, Assistant Town Manager, mparker@carrboronc.gov, (919) 918-7315

COUNCIL DIRECTION:

Race/Equity Climate Comprehensive Plan Other

The Town Council discussed major themes of racial equity, climate, and dedication to the Comprehensive Plan in conversations regarding the Land Use Ordinance, the FY24-25 budget, and their operating norms.

INFORMATION: The 2023-2024 Town Council retreat took place on February 3rd, 2024. During the retreat, Council discussed three major agenda items which included council priorities for the LUO rewrite, council priorities for the FY24-25 budget, and council norms. The summary report (attached) includes additional information on matters discussed.

In discussion of the LUO rewrite, Council prioritized the following goals for the rewrite: clarity, affordability, reducing the burden on those doing business with Carrboro, diversifying commercial-use in Carrboro, accessibility, racial equity, environmental protection, aligning LUO vision to the Comprehensive Plan, along with others.

Priorities identified for the FY 24-25 town budget included moving forward with the LUO rewrite, addressing compensation for the recruitment and retention of staff, and prioritizing the environment through stormwater infrastructure improvements and other means of environmental protections. Long-term budget priorities for the council focused on racial equity, creating a town conducive to multi-modal connectivity, and housing.

The Town Council worked together to create a set of six norms that would be used to aid in conducting effective and respectful business by Council. The six norms are “We will focus on policy outcomes and function as a team. We demonstrate mutual respect. We are action oriented. We are collective, collaborative problem-solvers. We use open communication. We assume good faith.”

FISCAL IMPACT: This item has no fiscal impact. Direction by Council on these matters will be accounted for in the FY24-25 budget.

Agenda Date: 5/7/2024
In Control: Town Council
Version: 2

File Type: Consent Agenda

RECOMMENDATION: Staff recommends that the Town Council affirm recommendations made in the retreat during the Council business meeting.



Carrboro Town Council Retreat Summary, February 3rd, 2024

LUO Goals:

- Clarity
 - Know what to expect
 - Fully understand this
- Reduce the burden of doing business in
 - Maintain community input
 - Reduce need
- Affordability
 - Plan for subsidies
 - Market rate
 - Definition of “by right” matches ○ “By right” zoning
- Diversify commercial-use
 - “Mom and Pop”
- Accessibility
 - Things residents need should be Racial equity
- Environmental protection
- Match vision of Comprehensive Plan
 - Objective standards
- We are not watering down projects from Sync future built environment with what We bring Carrboro together
 - We are all Carrboro
- A single goal (not two sets of goals)

Budget Priorities FY2024-2025:

Heavier Lifts

- **LUO/Economic Development**
 - LUO rewrite, including consultant
 - Budget to retain tax-neutral rate
- **Staff Recruitment/Retention**
 - Compensation + capacity
- **Environment**
 - Stormwater and infrastructure improvements
 - Environmental protection, tree canopy, stormwater/flooding

Longer-Term Priorities (Next Two Years):

Lighter Lifts

- **Race Equity**
 - Implement Community Safety Task Force recommendations
 - Implement race equity initiatives
 - The accessible language plan
- **Multi-Modal**
 - Multi-modal connectivity
 - SR2S
 - Bike plan
 - Greenways
 - Town-wide calming/resurfacing/complete streets
 - Robust micro transit program that encourages intra/inter-municipal transit
 - Circulator trolley Carrboro Chapel Hill
 - Bolin Creek Greenway

Heavier Lifts

- **Housing**
 - Subsidization of affordable housing that provides a pathway to ownership
 - Lease to own
 - Starter homes
 - Guideway to intergenerational wealth
 - Solving housing subsidization
 - 0-30, 30-60% AMI
 - Town investment vs. partners
 - Administration and maintenance
 - Ownership
 - Fund more housing support programs (emergency rent, repair, and weatherization)
 - Spend \$1 million for:
 - ARPA funding for affordable housing
 - RFP, scope of work
 - Town-owned land review
 - Home weatherization



Two other ideas that rose up during the conversation included:

- Fully funding town facilities upfit/renewal
- Economic development of nontraditional entrepreneurial enterprise

TOWN COUNCIL NORM DISCUSSION

The Ideal Carrboro:

- Everyone has representation and has a place in town.
- We are okay with the same vision but there might be different ways to get there.

Town Council Norms:

- *We focus on policy outcomes and function as a team.*
 - We all bring our lived experiences to the table.
- *We demonstrate mutual respect.*
 - Particularly in public
 - Policy (public) vs. personal (private)
 - Advocate for each other
- *We are action-oriented.*
 - Respect for resources and time
 - Primary reason we are here is to do work
- *We are collective, collaborative problem-solvers.*
 - We need to address issues.
 - Any view is not always a “community” view
 - We all represent community views.
 - “Name” who we are speaking for; be more specific
 - Avoid soapboxes and editorializing
- *We use open communication.*
 - Use speaking time to get to outcomes
 - Address issues
- *We assume good faith.*
 - Hold each other accountable
 - We need to reset to return to good faith after hard issues.

Additionally, the Council identified a few other ideas related to Council Norms:

- Start from a place of agreement and trust
- Listen to the community (all voices)
- Engage with those on the other side of “votes”
- We need to heal relationships when trust is broken.



Race and Equity Pocket Questions

Title and purpose of this initiative: Town Council 2023-2024 Retreat Summary; This item presents an opportunity for Council to discuss and formalize topics addressed in the 2024 Council retreat.

Department: Town Managers Office

What are the racial and equity impacts? This item alone has no race and equity impacts, however, if all the topics in this item were to be actionized then there would be many race and equity considerations. This item has three main topics: the LUO rewrite, the FY24-25 budget, and Council norms. During discussions of the LUO rewrite, Council discusses the racial equity specifically as an important consideration moving forward. Council also discusses racial equity as a key consideration in long term budget planning with the potential implementation of a community safety task force, a language access plan, and other race and equity initiatives. These proposals would ideally make Carrboro a more equitable, accessible, inclusive, and safe environment for all residents to live and work in.

Who is or will experience community burden? This item discusses a wide range of topics that would affect various sects of residents. There is a potential burden for those that benefit from current initiatives that may be cut or altered with the addition of new town initiatives. There is a potential burden on staff for being responsible for new initiatives. Neither of these burdens appear to be intended because of this item.

Who is or will experience community benefit? This item discusses a wide range of topics that would affect various sects of residents. First, there is a benefit to all Carrboro residents to have access to the retreat summary through this meeting so they may be more informed about initiatives by councilmembers. There is a potential benefit to business owners and entrepreneurial community members that may benefit from the LUO rewrite. There is a potential benefit for new residents, staff, and other community members that could benefit from new program included in the budget. There is also a benefit to Council with the establishment of the Council norms that ensure a respectful and productive working environment.

What are the root causes of inequity? There are no known causes of inequity in this item but one potential area for inequity would be that it was drafted solely by Carrboro Town Council. Councilmembers are elected by the public to represent their best interests, but the Mayor and Council are a small percentage Carrboro's resident base, making it difficult to represent all of the diverse interests of residents.

What might be the unintended consequences of this action or strategy? This item is not invoking formal action and thus should not have any consequences on its own. The LUO rewrite would potentially alter several of the town permitting and reporting requirements which could



TOWN OF CARRBORO • NC
FACING RACE, EMBRACING EQUITY

make it easier or more difficult for businesses and landowners in the town. It may change or alter services offered by the Town to accommodate for new services. It could also change the way in which Town Councilmembers interact with each other and residents of Carrboro as a result of new norms. Actions that could be taken as a result of this item may increase the workload of staff members.

How is your department planning to mitigate any burdens, inequities, and unintended consequences? This item requires no action and thus does not have any impact on the community at this time. As items are created with the direction of the council retreat, they will be evaluated for burdens, inequities, and unintended consequences at that time.



Agenda Item Abstract

File Number: 24-086

Agenda Date: 5/7/2024
In Control: Town Council
Version: 1

File Type: Other Matters

Report on *Carrboro Connects* Comprehensive Plan Implementation and Schedule for Land Use Ordinance Update

PURPOSE: To report on the status of comprehensive plan implementation and other priorities, including the anticipated scope and general schedule for updating the Town's land use regulations.

DEPARTMENT: Planning

CONTACT INFORMATION: Patricia McGuire, Planning Director, 919-918-7327 <mailto:pmcguire@carrboronc.gov>; Duncan Dodson, Planner, 919-918-7340, ddodson@carrboronc.gov; Christina Moon, Planning & Transportation Administrator, 919-918-7325, cmoon@carrboronc.gov; Bear Tosé, Planner, 919-918-7344, mtose@carrboronc.gov

COUNCIL DIRECTION:

Race/Equity Climate Comprehensive Plan Other

N.C. General Statutes, Chapter 160D, Article 5, requires that local governments have a reasonably maintained comprehensive or land use plan to retain authority to adopt and enforce zoning regulations. Adoption and maintenance of *Carrboro Connects* satisfies this requirement. Responses to the racial equity pocket questions have been prepared and are attached (*Attachment D*).

INFORMATION: *Carrboro Connects*, as adopted, included new projects and previous projects that were already underway. The plan prioritized 35 projects for implementation in the first five years due to their relationship to advancing racial equity and climate action. Upon adoption, the Town Manager worked with departments to begin the process of scheduling and budgeting for projects, identifying a method for reporting on progress, and considering how to incorporate changes in prioritization in relation to other needs and resource capacity, both in terms of staff and funding. This agenda item presents the third report on implementation of *Carrboro Connects*.

Status of Comp Plan Implementation. During the month of March, PZICAT staff met with department heads to understand the status of their assigned comprehensive plan projects. Directors were asked questions regarding the general progress of and next steps for their priority projects, as well as input on implementation. The results are detailed in two formats:

- Carrboro Connects Projects by Chapter - Status Report (*Attachment A*).
- Priorities that framed the FY23-24 Annual Budget - Status Report (*Attachment B*).

Comments related to possible adjustments in implementation are noted for several chapters. One comment not listed related to several chapters encourages prioritization of updating the Town's Land Use Ordinance to address multiple strategies (native plantings, tree canopy, SCMS, low-impact development, energy efficiency).

More info on this topic is provided below.

Most of the Comprehensive Plan projects include various steps for implementation, and the Town has made progress on numerous project steps towards completion/implementation. These steps include identifying actions that are needed to advance the vision of the comprehensive plan, such as several initiatives and programs funded through ARPA, the Language Access Plan, housing assistance funding, the ADA Transition Plan, the Title VI Plan, and others. Completion of REALs, pocket questions, and other racial equity analyses are being prepared consistent with the Racial Equity Action Plan as policies, programs, and practices are reviewed, formulated and decided upon.

The next overall update is anticipated for completion in the spring of 2025; reporting on the Key Priorities identified by the Town Council at its February 2024 Retreat will be included.

LUO Update - The 2022-2042 Carrboro Connects Comprehensive Plan identifies overall consistency between the LUO and the plan as a priority project (Land Use Strategy 4.1). In parallel, other strategies and priority projects outlined in *Carrboro Connects* benchmark and/or result in specific updates to the Land Use Ordinance. To match the vision of the Comprehensive Plan, and to advance projects with specific implementation strategies related to the LUO, staff are scoping this project and costs for possible budgeting in FY25. Details and information on the purpose, anticipated workplan, and schedule can be found in *Attachment C*.

Background - Meetings related to adoption and reporting on plan implementation to date have been as follows:

- 1) June 7, 2022 - Carrboro Connects adoption
 - a) Agenda - <https://carrboro.legistar.com/LegislationDetail.aspx?ID=5677720&GUID=39FB7236-77B1-48FC->
 - b) Minutes <https://carrboro.legistar.com/View.ashx?M=M&ID=921153&GUID=01E6F0D9-D4ED-459F-A3B4->
(see pages 7-8)
- 2) December 6, 2022 - Status Report
 - a) Agenda - <https://carrboro.legistar.com/LegislationDetail.aspx?ID=5955232&GUID=E3A499EB-33CB-4782->
 - b) Minutes - <https://carrboro.legistar.com/View.ashx?M=M&ID=991512&GUID=25603E66-F2D3-417A-A8E8->
(see pages 6-7)
- 3) February 21, 2023 - Town Council Retreat
 - a) Agenda <https://carrboro.legistar.com/MeetingDetail.aspx?ID=1062541&GUID=4D217FA4-390A-43AF-B29C->
 - b) Minutes - <https://carrboro.legistar.com/View.ashx?M=M&ID=1062541&GUID=4D217FA4-390A-43AF-B29C->
- 4) March 28, 2023 - Town Council Retreat Follow-up

- a) Agenda
<https://carrboro.legistar.com/LegislationDetail.aspx?ID=6105896&GUID=CFAE0141-AD36-421C->
- b) Minutes -
<https://carrboro.legistar.com/View.ashx?M=M&ID=1083200&GUID=F56C08E1-707A-4446-88FE->
- 5) September 26, 2023
 - a) Agenda
<https://carrboro.legistar.com/LegislationDetail.aspx?ID=6360973&GUID=342EC3B3-5D40-42CE->
- 6) February 3, 2024 - Town Council Retreat
 - a) Agenda
<https://carrboro.legistar.com/MeetingDetail.aspx?ID=1154099&GUID=420A000D-8F39-4EC9-9AE1->

FISCAL IMPACT: There is no fiscal impact associated with receiving this report. Budgetary decisions related to comprehensive plan implementation, including the update of land use regulations, are expected to occur with adoption of the Town's annual budget.

RECOMMENDATION: Staff recommends that the Town Council receive the report, ask questions, and provide feedback on Carrboro Connects and related priorities implementation.

Carrboro Connects Projects by Chapter - Status Report

Chapter	Progress Update
Affordable Housing, Chapter 3	<p>Priority Projects</p> <ul style="list-style-type: none"> • Strategy 1.2A: Staff identifying gaps to creating pathways to homeownership for low-income and BIPOC residents • Strategy 3.4: Assessment of Pathway Drive and Crest Street parcels underway for affordable housing development • After report, project may need to hire an engagement facilitator and/or bring in a developer • Strategy 4.5: Staff scoping out a \$500,000 ARPA-funded contract with Rebuilding the Triangle to provide weatherization to roughly 25 homes • Strategy 6.2: Staff actively identifying federal funding opportunities for affordable housing development <p>Other Comp Plan Projects</p> <ul style="list-style-type: none"> • 2.2B: Targeting projects for extremely low-income households in communication with AHF applicants • 4.2: ARPA funding award to EMPOWERment to preserve 10 affordable units • 5.1: Continued partnership with OCPEH and IFC; Reallocated ARPA funding to the Carrboro Financial Assistance program • 6.1A,B: Staff monitoring property tax rates, increasing funding requests, and seeking additional grant funding <p>Suggested Implementation Amendments</p> <ul style="list-style-type: none"> • Consider delaying projects 1.2A and 6.2 due to capacity, timing, and local market challenges
Climate and Environment, Chapter 4	<p>Priority Projects</p> <ul style="list-style-type: none"> • CA 1.2A: Launching the Energy Efficiency Revolving Loan Fund this spring • CA 4.2D: Collaborating on Inflation Reduction Act grant for EV charging stations with local jurisdictions and Central Pines Regional Council • CA 4.1B: Staff scoping a structure for a Rental Housing Task Force to address multifamily energy efficiencies <p>Other Comp Plan Projects</p> <ul style="list-style-type: none"> • ENV 1.1C: Outreach and engagement events conducted and planned for Creek Week, Earth Day, Pollinator Week, etc. • Chapter 10 - Municipal Operations 1.A,B: Fleet Study complete. Recommendations include purchasing the Town’s first electric battery car and updating others to Hybrid models <p>Suggested Implementation Amendments</p> <ul style="list-style-type: none"> • Expand priority project 4.1B to strategy 4.1 generally
Transportation and Mobility, Chapter 5	<p>Priority Projects</p> <ul style="list-style-type: none"> • 2.1A: MPO just finished regional transit service survey; Biannual survey currently being conducted to identify potential projects

	<ul style="list-style-type: none"> • 2.2G: Current call for projects through MPO; S. Greensboro sidewalk design underway • Staff considering aligning sidewalks analysis with ADA Transition Plan • 2.2k: Jones Ferry Road resurfacing to add westbound buffered bike lanes; Bundle of bike implementation projects submitted for funding; Design underway for rapid flashing beacons at Homestead/Claremont and McDougle • 4.1E: Collaborating on Inflation Reduction Act grant for EV charging stations with local jurisdictions and Central Pines Regional Council • 4.2: Parking Maximums Text Amendment <p>Other Comp Plan Projects</p> <ul style="list-style-type: none"> • 1.1A: Completion of Residential Traffic Calming REAL • 2.1B: Awarded TDM grant and working with OC to create senior programming • 2.2A: Complete Streets Text Amendment • 2.2H: Awarded a grant to update SRTS grant that will include the addition of Morris Grove Elementary
<p>GSI, Water and Energy, Chapter 6</p>	<p>Priority Projects</p> <ul style="list-style-type: none"> • WAT 2.1B: Stormwater management incentive program under implementation for income-eligible households • Additional funding approved to hire for a new staff position focused on program admin and expansion • GSI 4.1B: Staff conducted site assessments to create a master spreadsheet of retrofit tools, currently being published on webpage <p>Other Comp Plan Projects</p> <ul style="list-style-type: none"> • GSI 1.1 B,C; WAT 2.1D; WAT 2.1E: Recommendations integrated into ongoing operations. • GSI 1.3A: Solar Arrays installed on Fire Station 1 and PW Buildings. • WAT 2.1A,C: 319 Grant/Regenerative Stormwater Conveyance project (Bolin Forest) complete; Submitted Local Assistance for stormwater infrastructure improvements grants application .
<p>Economic Sustainability, Chapter 7</p>	<p>Priority Projects</p> <ul style="list-style-type: none"> • 1.1: Revolving Loan Fund in implementation for small businesses with additional provisions for BIPOC-owners • 1.2: Staff partnering with EmPOWERment to do cohort and pop-up training for BIPOC businesses • 2.1: Authorized contract for Downtown Area Plan with stakeholder engagement to begin Spring/Summer 2024 • Parking enforcement, paid parking policy, and wayfinding recommendations presented to Council (February 2024) • 203 Project scheduled to open Summer/Fall 2024 • 3.3: Staff working with Chapel Hill Tourism to design a brochure for Carrboro

	<p>Other Comp Plan Projects</p> <ul style="list-style-type: none"> • 3.2, 4.3: Staff exploring opportunities for “artisan production” and small industry development <p>Suggested Implementation Amendments</p> <ul style="list-style-type: none"> • Narrow scope of priority projects to focus on specific goals, not overall strategies • Consider revising “light manufacturing” language in Goal 1.1B
<p>Recreation, Parks, and Cultural Resources, Chapter 8</p>	<p>Priority Projects</p> <ul style="list-style-type: none"> • 2.1B: Staff working with HOAs to identify private amenities and better understand the existing recreational infrastructure • 2.3C: Staff working with C&E, Chapel Hill, and OC, to promote public park facilities with kickoff in April • 2.5A: Ongoing improvements to greenways, trails, and open space • 4.3A: Staff working with Arts Committee and Rec & Parks Commission to identify potential opportunities for installations • ARPA funding secured to go to 1-2 murals <p>Suggested Implementation Amendments</p> <ul style="list-style-type: none"> • Delay priority project 1.1B due to timing and funding • Consider formal tools for Comp Plan project management • Prioritize R&P Master Plan and ADA Transition Plan to be competitive for grants
<p>Land Use, Chapter 9</p>	<p>Priority Projects</p> <ul style="list-style-type: none"> • 2.1A: Authorized contract for Downtown Area Plan with stakeholder engagement to begin Spring/Summer 2024 • Funding requested for second SAP in FY24-25 Budget • 2.2,5.1: Staff integrating this into SAP and LUP Update projects • 4.1: Staff scoping a procurement process for LUO Update; Funding request in FY24-25 Budget • 5.2: Staff creating a nested survey to refine development approval process <p>Other Comp Plan Projects</p> <ul style="list-style-type: none"> • 2.2B, 2.4: Staff began a geospatial inventory of uses and parcels for a transit-oriented overlay district • 3.1F: Urban tree cover incorporated into Downtown Area Plan scope and LUO admin • 6.2C: S. Greensboro sidewalk connects to FPG and Carrboro High • 8.1A: Authorized contract for Downtown Area Plan, which incorporates the Jones Ferry corridor growth area

Priorities that Framed FY23-24 Annual Budget - Status Report

Priority	Progress Update
Race & Equity Initiatives	<ul style="list-style-type: none"> • 25% complete with evaluation of town policies, practices, and procedures. • Adopted the Racial Equity Action Plan (2023). • Implementing framework for Summary REAL, pocket questions and related to attach to agenda items for completed lenses for policies, practices, and procedures. • Town Council agendas with Council Direction statement and related pocket questions, summary REALs and related. • One Orange Data Index dashboard. • Staff training program development.
Community Climate Action Plan	<ul style="list-style-type: none"> • Undergoing Round 2 of Green Neighborhood Grants. Application period ends early May awards expected to be distributed in June. • Planning to launch Energy Efficiency Revolving Loan Fund this spring. (CA&E 1.2A) • Fleet Study is complete. Part of recommendations include purchasing the Town's first electric battery car for the Police Department (Community Services) and updating others to Hybrid models. • Climate Action Intern implementing multifamily composting pilot across four multi-family communities. • Outreach and engagement events conducted and planned for Creek Week, Earth Day, Pollinator Week, etc. • Continuing to collaborate with other local jurisdictions and Central Pines Regional Council to submit a proposal for EV charging stations through the Inflation Reduction Act. (CA&E 4.2D) • Staff are scoping out a structure for a Rental Housing Task Force to address energy performance and efficiencies. (CA&E 4.1B)
Zoning Amendments	<ul style="list-style-type: none"> • Authorized contract for Downtown Area Plan with stakeholder engagement to begin this spring/summer. The project is the first of four identified small area plans and will focus on the commercial areas of downtown as well as the Jones Ferry Corridor. (LU 2.1A) • Text amendments for adoption in June to update and clarify several provisions of LUO, including updates to fencing requirements, water quality buffer allowable uses and variance procedures, setback variances and road buffer requirements. • Scoping a procurement process for LUO update underway towards release in early FY 25.
Connectivity, Bicycle, Pedestrian	<ul style="list-style-type: none"> • Jones Ferry Road – resurfacing to add westbound buffered bike lanes. Center median work completed, NCDOT to resurface this summer.

	<ul style="list-style-type: none"> • South Greensboro Street Sidewalk – design underway, waterline replacement design nearing completion, coordination with NCDOT in progress to schedule street resurfacing in conjunction with project delivery. • Signalized pedestrian crossings along NC 54 West – design completed. construction anticipated for the fall; NCDOT to manage construction. • Bundle of Bike Plan Implementation Projects (Shelton St, Poplar Ave, Maple Ave), and Bolin Creek Phases 2, 3, and 4 were submitted for allocation of funds from the Regional Flexible Fund (RFF). The bike plan implementation and design for Bolin Creek Phase 2 are included in the projects under consideration for funding. • SRTS Non infrastructure grant awarded to Town for update to SRTS plan which will include the addition of Morris Grove Elementary, RFP scoping with TAB/SRTS Implementation Committee. • ARPA projects include Rectangular Rapid Flashing Beacons at Homestead/ Claremont and McDougle – design work about to get underway.
Comprehensive Plan	<ul style="list-style-type: none"> • PZI met with department heads to review progress and coordinate this update to the Council scheduled for May 7, 2024. Comprehensive plan priority projects were discussed in context with budget and staff capacity. • Where staff has made progress on priority projects related to these strategic priorities is reflected in parentheses next to relevant, bulleted updates. • Staff working with Homeowners Associations to identify private amenities and better understand the existing recreational infrastructure. (RP&CR 1.1B) • Staff working with Communications & Engagement, Chapel Hill, and Orange County to promote public park facilities with kickoff in April. (RP&CR 2.3C) • Staff working with Arts Committee and Recreation and Parks Commission to identify potential opportunities for art projects. ARPA funding secured to go towards 1-2 murals. (RP&CR 4.3A) • Staff creating a nested survey to refine development approval process. The target stakeholders include applicants, advisory board members, council members, and community. (LU 5.2)
Safety Task Force	Report received; work planned and underway
Affordable Housing	<ul style="list-style-type: none"> • Assessment of Pathway Drive and Crest Street parcels underway for affordable housing development. After report, project may need financial support to hire an engagement facilitator and/or bring in a developer. (AH 3.4) • Staff scoping out a \$500,000 ARPA-funded contract with Rebuilding the Triangle to provide weatherization to roughly 25 homes. (AH. 4.5) • Staff actively identifying federal funding opportunities for affordable housing development. (AH 6.2) • Staff updating list of local organizations providing assistance and identifying gaps that could be filled by the Town as it relates to creating

	a pathway to homeownership for low-income and BIPOC residents. (AH 1.2A)
Develop/ Achieve Operational Efficiencies	Town Manager’s Office and Planning implementing recommendations.
Strategic Plan/ Performance Management	<ul style="list-style-type: none"> • Currently reviewing internal performance measurement plans in prior budgets.
Town Building Renovations	<ul style="list-style-type: none"> • Security door at Finance • ID Electronic Lock/Entry System • Camera installation
Infrastructure Improvements	<ul style="list-style-type: none"> • Stormwater management incentive program under full implementation for income eligible residential households. Additional funding was approved earlier this year to hire for a new staff position focused on program administration and expansion. (WAT 2.1B) • Public Works Stormwater Division conducted site assessments to create a master spreadsheet of retrofit tools currently being published on webpage. (GSI 4.1B) • Condition assessment work underway relevant to flooding and erosion concerns.
Economic Development	<ul style="list-style-type: none"> • Revolving Loan Fund in implementation for small businesses with additional provisions for BIPOC-owners. (ES 1.1) • Staff beginning to collect data on “artisan production” and small industry development opportunities. (ES 1.1) • Partnering with Empowerment to do cohort and pop-up training for BIPOC businesses. (ES 1.2) • Authorized contract for Downtown Area Plan with stakeholder engagement to begin this spring/summer. (ES 2.1) • Staff working with Chapel Hill Tourism to design a brochure for Carrboro. (ES 3.3) • Parking enforcement and paid parking policy recommendations presented to Council on February 23, 2024.
203 Project	Construction is approximately 55% complete and the building is on schedule to open fall 2024.

Land Use Ordinance Update Summary

Why should the LUO be updated?

The Town of Carrboro Land Use Ordinance (LUO) was adopted in November 1980, following adoption of the Town’s 1977 Land Use Plan and as the state’s first Unified Development Ordinance to combine traditional zoning and subdivision regulations with other Town regulations including building and street design standards and water quality protection, among others. The LUO has been amended and updated many times over its 44-year history to 1) stay compliant with the authority granted by the NC General Assembly; 2) to reflect newer plans, studies, and policies, such as the Facilitated Small Area Plan for the Northern Study Area, the Joint Planning Land Use Plan, Bike Plans and Parking studies and plans; and 3) to respond to changing information and requests at the neighborhood and property scale.

The 2022-2042 *Carrboro Connects* Comprehensive Plan identifies overall consistency between the LUO and the plan as a priority project (Land Use Strategy 4.1). With the adoption of the 2023 Race & Equity Action Plan, 2020 Community Climate Action Plan, 2020 Update to the Bike Plan, and 2024 Language Access Plan, there is overall momentum in the Town of Carrboro to evaluate and update land use regulations to ensure that any past disparities are eliminated, the natural environment is more resilient to climate change, and everyone has the opportunity to participate in our community’s development.

Who will be involved in the LUO Update?

The LUO Update will require the involvement of residents, property owners, development community, specialists in related land use and development standards development and administration, Town Council Members, Advisory Boards and Commissions, Town Attorney, and staff.

Planning staff and a consultant team will act as the main project coordinators. Specific departmental staff (e.g. Public Works and Housing & Community Services) will play a greater role in aspects of their related ordinance analyses and drafting.

How are staff preparing for the LUO Update?

Staff have looked at other municipal unified development ordinances to explore potential structural improvements as well as identify tools that allow for digital accessibility and translation of the document. For comprehensive plan consistency, the *Carrboro Connects* implementation timeline identifies benchmark LUO Updates for priority projects in or beyond 2026. Consistency with *Carrboro Connects* will result from parallel or phased impact analyses, performance standards development, and the drafting of complex legal language.

Staff are scoping the breadth of analyses identified to implement *Carrboro Connects* and compiling previous evaluations of the LUO and any existing challenges towards drafting a Request for Proposals (RFP). This project will benefit from a consultant team with experience in analysis, ordinance reorganization, and policy drafting experience in close collaboration with staff. Funding for an LUO Update has been requested for FY24-25. If approved as part of the budget for FY25, the procurement process would be expected to get underway quickly and the

update process initiated before the end of the 2024 calendar year. A time frame of 18-24 months is expected for project completion.

What does *Carrboro Connects* call for in an LUO Update?

The LUO Update will seek to accomplish three overarching objectives: increasing accessibility, structure, and presentation of the document; aligning the LUO with strategies identified in *Carrboro Connects*, the Community Climate Action Plan, and the 2009 Bike Plan and 2020 Update; and ensuring continued compliance with the Town’s regulatory authority and the NC General Statutes.

Accessibility and usability of the LUO will also be critical to the update, guided by policies and interdepartmental work from our Race and Equity team and our Communication and Engagement Team. Reorganization of definitions, use classes, performance standards, and appendix diagrams will make the ordinance easier to use by the community, applicants, and council members.

Alignment with existing plans and strategies will, for many topics, require and/or benefit from analyses of existing conditions, review of policy impacts from peer municipalities, and forecasting impacts. For example, the Town is interested in understanding the relationships between increases in residential density and intensity of development overall affects housing affordability, utility capacity and infrastructure, traffic volumes and safety, and economic and environmental sustainability.

Carrboro Connects outlines several projects with benchmarks that call for a review of the LUO and associated analyses. If such reviews and analyses find inconsistency with *Carrboro Connects*, the plan calls for updates to the LUO.

The reviews and analyses identified in *Carrboro Connects* include:

Chapter	Topic for Review and Potential LUO Update
Affordable Housing	<ul style="list-style-type: none"> • Impacts of increased provision of Accessory Dwelling Units (ADUs) • Opportunities for increasing housing density within the water and sewer boundary
Climate Action & Environment	<ul style="list-style-type: none"> • Urban heat island effects and subsequent mitigation • Integration of renewable energy infrastructure in development review • Protection of streams and riparian areas
Transportation & Mobility	<ul style="list-style-type: none"> • Design standards for streets and sidewalks to reduce speed and increase safety • Parking requirements impacts on housing costs and natural resources
Green Stormwater Infrastructure, Water, & Energy	<ul style="list-style-type: none"> • Incentive programs for stormwater management or infrastructure mitigation • Structural and non-structural measures for redevelopment and infill • Integration of green stormwater management into traffic calming

Economic Sustainability	<ul style="list-style-type: none">• Higher density and mixed-use development downtown• Strengthen business districts and commercial areas
Land Use	<ul style="list-style-type: none">• Increased density along transit corridor and nodes• Higher residential density in appropriate areas• Updates from recommendations of small area plans• Development review process changes

Race and Equity Pocket Questions

Title and purpose of this initiative:

Report on Carrboro Connects Comprehensive Plan Implementation and Schedule for Land Use Ordinance Update. To report on the status of comprehensive plan implementation and other priorities, including the anticipated workplan and schedule for updating the Town’s land use regulations.

Department: Planning

What are the racial and equity impacts?

Thirty-five (35) of the projects outlined in the implementation chapter of the Carrboro Connects 2022-2042 Comprehensive Plan were identified by stakeholders and staff as priority projects. These projects were chosen because they were identified by community members and the Carrboro Connects Task Force as strategies and/or projects that would best advance race and equity, and climate action. Additionally, they were identified as priorities due to their likelihood of having the greatest cross-cutting, positive community impact over the next five years. Some priority projects have a specific geographic scope, most of which call for the determination of such areas of interest/impact to center the consideration of race and equity. Projects that relate to policies and/or to the Town as a whole outline specific steps to analyze and address racial inequities. More detail can be found in Carrboro Connects Chapter 11 – Implementation (11-Implementation (carrboronc.gov)). The Town Council 2023 Retreat also included the review and selection of priorities from the Comp Plan and other sources. Reporting on the progress of implementation of both sets of linked priorities occurs routinely via Communication and Engagement channels (e.g. open houses, tabling, TICs, news flashes and newsletters and related), is posted on the Town’s website, and is scheduled for Town Council action where needed.

Who is or will experience community burden?

Due to the wide breadth of scope and topic projects—five projects from each of the seven elements of the plan— those who will experience burden will vary in relation to the specific projects, and on the phase of each project’s implementation and will be assessed and evaluated as those phases and projects proceed, consistent with the use of One Orange tools including pocket question and REAL lens completion.

Who is or will experience community benefit?

Due to the wide breadth of scope and topic projects—five projects from each of the seven elements of the plan— those who will experience benefit will vary in relation to the specific projects, and on the phase of each project’s implementation and will be assessed and evaluated as those phases and projects proceed, consistent with the use of One Orange tools including pocket questions and

REAL lens completion.

What are the root causes of inequity?

Inequities stem from systemic racism, from policies that have excluded marginalized communities and from planning theories that do not adequately recognize, or address, disparity. Addressing these root causes is a foundational element of the Comprehensive Plan and a primary factor in the selection of the projects. More information regarding the respective inequities, unintended consequences, and mitigation strategies can be found within *Carrboro Connects*, the Race and Equity Action Plan, as well as part of relevant pocket questions and REAL lenses.

What might be the unintended consequences of this action or strategy?

Carrboro Connects contains many projects and priorities, as do other adopted plans in the Town. These projects can affect opportunities and experiences, land values, and the quality of life for surrounding property owners and occupants in ways that can be beneficial and, albeit for some, less desirable. Due to the large number of projects, an unintended consequence of advancing any of them is that others will not be advanced. The Town's policies and procedures seek to maximize engagement by assessing stakeholders in relation to the details of actions or projects – however, some may be missed.

With published notice, signage, mailings, and social media releases, some people may not learn of engagement sessions and input opportunities in time to provide input and/or feel that they understand the project and/or approval process enough to fully participate.

Shortages of staff or other resources may limit capacity to carry out projects, and related communications and engagement, in a routine manner. Racial equity analyses may lengthen project completion; some may be more, and others less, complete based on availability of applicable data.

How is your department planning to mitigate any burdens, inequities, and unintended consequences?

The department will continue to review and modify the ways in which planning processes are scoped and carried out. The department will work to prevent and remove requirements that result in new or perpetuate existing disparities based on race. The department will continue to evaluate the environmental justice and equity tools used in these processes to determine if they assist with improving and expanding engagement beyond the requirements associated with state law and the Town's authority to adopt and amend its land use regulations. The department anticipates continued refinement of racial equity tools internally and with regional municipal partners can improve racial equity analysis procedures and help identify data gaps that partners can work long-term to fill.